

---

---

**UNITED STATES  
SECURITIES AND EXCHANGE COMMISSION**  
Washington, D.C. 20549

---

**Form 10-K**

**ANNUAL REPORT PURSUANT TO SECTION 13 OR 15(D) OF THE SECURITIES EXCHANGE ACT OF 1934**  
For the fiscal year ended **December 31, 2005**

OR

**TRANSITION REPORT PURSUANT TO SECTION 13 OR 15(D) OF THE SECURITIES EXCHANGE ACT OF 1934**  
For the transition period from \_\_\_\_\_ to \_\_\_\_\_

Commission File No. **001-16383**

---

**CHENIERE ENERGY, INC.**

(Exact name of registrant as specified in its charter)

**Delaware**  
(State or other jurisdiction of incorporation or organization)

**95-4352386**  
(I.R.S. Employer Identification No.)

**717 Texas Avenue, Suite 3100**  
**Houston, Texas**  
(Address of principal executive offices)

**77002**  
(Zip code)

Registrant's telephone number, including area code: **(713) 659-1361**

Securities registered pursuant to Section 12(b) of the Act:

**None**

Securities registered pursuant to Section 12(g) of the Act:

**Common Stock, \$ 0.003 par value**  
(Title of Class)

**American Stock Exchange**  
(Name of each exchange on which registered)

---

Indicate by check mark if the registrant is a well-known seasoned issuer, as defined in Rule 405 of the Securities Act. Yes  No

Indicate by check mark if the registrant is not required to file reports pursuant to Section 13 or Section 15(d) of the Exchange Act. Yes  No

Indicate by check mark whether the registrant (1) has filed all reports required to be filed by Section 13 or 15(d) of the Securities Exchange Act of 1934 during the preceding 12 months (or for such shorter period that the registrant was required to file such reports), and (2) has been subject to such filing requirements for the past 90 days. Yes  No

Indicate by check mark if disclosure of delinquent filers pursuant to Item 405 of Regulation S-K is not contained herein, and will not be contained, to the best of the registrant's knowledge, in definitive proxy or information statements incorporated by reference in Part III of this Form 10-K or any amendment to this Form 10-K.

Indicate by check mark whether the registrant is a large accelerated filer, an accelerated filer, or a non-accelerated filer. See definition of "accelerated filer and large accelerated filer" in Rule 12b-2 of the Exchange Act.

Large accelerated filer  Accelerated filer  Non-accelerated filer

Indicate by check mark whether the registrant is a shell company (as defined in Rule 12b-2 of the Exchange Act). Yes  No

The aggregate market value of the registrant's Common Stock held by non-affiliates of the registrant was approximately \$1,508,000,000 as of June 30, 2005.

54,742,805 shares of the registrant's Common Stock were outstanding as of February 28, 2006.

**Documents incorporated by reference: The definitive proxy statement for the registrant's Annual Meeting of Stockholders (to be filed within 120 days of the close of the registrant's fiscal year) is incorporated by reference into Part III.**

---

---

---

**Table of Contents****CHENIERE ENERGY, INC.**  
Index to Form 10-K

<b>Part I</b>	<b>2</b>
<i>Items 1. and 2. Business and Properties</i>	2
<u>General</u>	2
<u>General Development of Our Business</u>	3
<u>LNG Receiving Terminal Development Business</u>	4
<u>Natural Gas Pipeline Development Business</u>	20
<u>LNG and Natural Gas Marketing Business</u>	26
<u>Oil and Gas Exploration and Development Business</u>	28
<u>Financial Information About Segments</u>	34
<u>Subsidiaries</u>	34
<u>Employees</u>	34
<i>Item 1A. Risk Factors</i>	35
<u>Risks Relating to Our Financial Matters</u>	35
<u>Risks Relating to Our LNG Receiving Terminal Development Business</u>	37
<u>Risks Relating to Our Pipeline Development Business</u>	41
<u>Risks Relating to Our LNG and Natural Gas Marketing Business</u>	43
<u>Risks Relating to Our Oil and Gas Exploration and Development Business</u>	44
<u>Risks Relating to Our Business in General</u>	47
<i>Item 1B. Unresolved Staff Comments</i>	51
<i>Item 3. Legal Proceedings</i>	51
<i>Item 4. Submission of Matters to a Vote of Security Holders</i>	52
<b>Part II</b>	<b>52</b>
<i>Item 5. Market Price for Registrant's Common Equity, Related Stockholder Matters and Issuer Purchases of Equity Securities</i>	52
<i>Item 6. Selected Financial Data</i>	53
<i>Item 7. Management's Discussion and Analysis of Financial Condition and Results of Operation</i>	54
<u>General</u>	54
<u>Liquidity and Capital Resources</u>	55
<u>Results of Operations—Comparison of the Fiscal Years Ended December 31, 2005 and 2004</u>	63
<u>Results of Operations—Comparison of the Fiscal Years Ended December 31, 2004 and 2003</u>	65
<u>Other Matters</u>	67
<i>Item 7A. Quantitative and Qualitative Disclosures About Market Risk</i>	70
<u>Interest Rates</u>	71
<i>Item 8. Financial Statements and Supplementary Data</i>	72
<i>Item 9. Changes in and Disagreements with Accountants on Accounting and Financial Disclosure</i>	116
<i>Item 9A. Controls and Procedures</i>	116
<i>Item 9B. Other Information</i>	116
<b>Part III</b>	<b>116</b>
<b>Part IV</b>	<b>116</b>
<i>Item 15. Exhibits and Financial Statement Schedules</i>	116

**CAUTIONARY STATEMENT  
REGARDING FORWARD-LOOKING STATEMENTS**

This annual report contains certain statements that are, or may be deemed to be, “forward-looking statements” within the meaning of Section 27A of the Securities Act of 1933, as amended, and Section 21E of the Securities Exchange Act of 1934, as amended, or the Exchange Act. All statements, other than statements of historical facts, included herein or incorporated herein by reference are “forward-looking statements.” Included among “forward-looking statements” are, among other things:

- statements that we expect to commence or complete construction of each of our proposed liquefied natural gas, or LNG, receiving terminals or our proposed pipelines, or any expansions or extensions thereof, by certain dates, or at all;
- statements that we expect to receive Draft Environmental Impact Statements, or DEIS, or Final Environmental Impact Statements, or FEIS, from the Federal Energy Regulatory Commission, or FERC, by certain dates, or at all, or that we expect to receive an order from FERC authorizing us to construct and operate proposed LNG receiving terminals or proposed pipelines by certain dates, or at all;
- statements regarding future levels of domestic or foreign natural gas production or consumption or future levels of LNG imports into North America or sales of natural gas in North America, regardless of the source of such information, or the transportation or other infrastructure or prices related to natural gas, LNG or other hydrocarbon products;
- statements regarding any financing transactions or arrangements, or ability to enter into such transactions, whether on the part of Cheniere or at the project level, including financing arrangements for which we may have received commitment letters;
- statements relating to the construction of our proposed LNG receiving terminals and our proposed pipelines, including statements concerning the engagement of any engineering, procurement and construction, or EPC, contractor and the anticipated terms and provisions of any agreement with an EPC contractor, and anticipated costs related thereto;
- statements regarding any terminal use agreement, or TUA, or other agreement to be entered into or performed substantially in the future, including any cash distributions and revenues anticipated to be received and the anticipated timing thereof, and statements regarding the amounts of total regasification capacity that is, or may become subject to, TUAs or other contracts;
- statements that our proposed LNG receiving terminals and pipelines, when completed, will have certain characteristics, including amounts of regasification and storage capacities, a number of storage tanks and docks, pipeline deliverability and the number of pipeline interconnections, if any;
- statements regarding possible expansions of the currently projected size of any of our proposed LNG receiving terminals;
- statements regarding our business strategy, our business plans or any other plans, forecasts or objectives, any or all of which are subject to change;
- statements regarding any Securities and Exchange Commission, or SEC, or other governmental or regulatory inquiry or investigation;
- statements regarding anticipated legislative, governmental, regulatory, administrative or other public body actions, requirements, permits or decisions;
- statements regarding our anticipated LNG and natural gas marketing activities; and
- any other statements that relate to non-historical or future information.

These forward-looking statements are often identified by the use of terms and phrases such as “achieve,” “anticipate,” “believe,” “estimate,” “expect,” “forecast,” “plan,” “project,” “propose,” “strategy” and similar

---

## Table of Contents

terms and phrases. Although we believe that the expectations reflected in these forward-looking statements are reasonable, they do involve assumptions, risks and uncertainties, and these expectations may prove to be incorrect. You should not place undue reliance on these forward-looking statements, which speak only as of the date of this annual report.

Our actual results could differ materially from those anticipated in these forward-looking statements as a result of a variety of factors, including those discussed in “Risk Factors” beginning on page 35 of this annual report. All forward-looking statements attributable to us or persons acting on our behalf are expressly qualified in their entirety by these risk factors. These forward-looking statements are made as of the date of this annual report. Other than as required under the securities laws, we assume no obligation to update or revise these forward-looking statements or provide reasons why actual results may differ.

## PART I

### ITEMS 1. AND 2. BUSINESS AND PROPERTIES

#### General

Cheniere Energy, Inc., a Delaware corporation, is a Houston-based company engaged, through its subsidiaries, in the energy business generally. As used in this annual report, the terms “we”, “us” and “our” refer to Cheniere Energy, Inc. and its subsidiaries. We are currently engaged primarily in the business of developing and constructing, and then owning and operating, a network of three onshore LNG receiving terminals, and related natural gas pipelines, along the Gulf Coast of the United States. We are also engaged, to a limited extent, in oil and natural gas exploration and development activities in the Gulf of Mexico.

Our common stock has been publicly traded since July 3, 1996 under the name Cheniere Energy, Inc. Our common stock is traded on the American Stock Exchange under the symbol LNG. Our principal executive offices are located at 717 Texas Avenue, Suite 3100, Houston, Texas 77002, and our telephone number is (713) 659-1361. Our internet address is [www.cheniere.com](http://www.cheniere.com). We provide public access to our annual reports on Form 10-K, quarterly reports on Form 10-Q, current reports on Form 8-K, and amendments to these reports as soon as reasonably practicable after we electronically file those materials with, or furnish those materials to, the SEC under the Exchange Act. These reports may be accessed free of charge through our internet website (located at [www.cheniere.com](http://www.cheniere.com)), where we provide a link to the SEC’s website (at [www.sec.gov](http://www.sec.gov)). We make our website content available for informational purposes only. The website should not be relied upon for investment purposes nor is it incorporated by reference into this Form 10-K.

In this annual report, unless the context otherwise requires:

- *Bcf* means billion cubic feet;
- *Bcf/d* means billion cubic feet per day;
- *Bcfe* means billion cubic feet of natural gas equivalent, using the ratio of six Mcf of natural gas to one barrel (or 42 United States gallons of liquid volume) of crude oil, condensate and natural gas liquids;
- *cm* means cubic meter;
- *EPC* means engineering, procurement and construction;
- *IPA* means indexed purchase agreement;
- *LNG* means liquefied natural gas;
- *Mcf* means thousand cubic feet;
- *MMcf* means million cubic feet;
- *MMcf/d* means million cubic feet per day;

---

## Table of Contents

- *MMBtu* means million British thermal units;
- *Tcf* means trillion cubic feet; and
- *TUA* means terminal use agreement.

### **General Development of Our Business**

We were originally incorporated in Delaware in 1996 under the name Cheniere Energy Operating Co. for the purpose of engaging in the oil and gas exploration business, initially on the Louisiana Gulf Coast. In 1996, we underwent a reorganization with a publicly-held corporation, pursuant to which we became a publicly-held corporation and changed our name to Cheniere Energy, Inc. In 1999, we began developing our LNG receiving terminal business.

We are pursuing a business strategy with the following primary components:

- complete the development and construction of our three onshore U.S. Gulf Coast LNG receiving terminals with an aggregate designed regasification capacity of approximately 10 Bcf/d, subject to further expansion;
- secure an additional 2 Bcf/d of long-term arrangements under TUAs with creditworthy “anchor tenants,” resulting in approximately 4 Bcf/d of our total existing and future regasification capacity, thus providing for an expected stream of contracted cash flows as terminals become operational;
- secure long-term indexed purchase agreements, or IPAs, for approximately 3 Bcf/d through the purchase of LNG from foreign suppliers and the sale of revaporized natural gas into North American markets, utilizing our planned regasification capacity;
- reserve approximately 3 Bcf/d of regasification capacity for future short-term or spot market opportunities and terminal operations requirements;
- grow our LNG receiving terminal business by expanding our existing projects and potentially pursuing development of additional LNG receiving terminals on the U.S. Gulf Coast and elsewhere;
- develop natural gas pipelines and other infrastructure to transport natural gas from our LNG receiving terminals to North American markets;
- to complement our LNG receiving terminal business, develop our LNG and natural gas marketing business by entering into domestic natural gas purchase and sale transactions;
- pursue other energy business initiatives, including participating in projects that own or are developing foreign natural gas reserves that could be converted into LNG and investing in LNG shipping businesses; and
- engage in additional oil and gas exploration, development, production, transportation and processing activities generally.

Within the context of this long-term strategy, our immediate focus is on our LNG receiving terminals being developed in western Cameron Parish, Louisiana on the Sabine Pass Channel and near Corpus Christi, Texas. We have allocated 2.5 Bcf/d of regasification capacity within these two terminals to our marketing affiliate (1.5 Bcf/d at Sabine Pass and 1.0 Bcf/d at Corpus Christi) to enable it to pursue approximately 200 LNG cargoes annually for its *LNG Gateway*<sup>™</sup> program. In April 2006, we anticipate offering the remaining regasification capacity in Sabine Pass (500 MMcf/d) to potential TUA customers through a formal request-for-proposal process. As we see the market develop for regasification capacity, we will introduce from time to time additional capacity at our Corpus Christi LNG receiving terminal through the same request-for-proposal process.

We anticipate reserving the regasification capacity at our Creole Trail LNG receiving terminal for strategic relationships.

---

## Table of Contents

We operate four business activities:

- LNG receiving terminal development,
- natural gas pipeline development,
- LNG and natural gas marketing, and
- oil and gas exploration and development.

At this stage in our development, our operations are divided into two reporting segments in our financial statements for the years ended December 31, 2005, 2004 and 2003 as required under Statement of Financial Accounting Standards (SFAS) No. 131, "*Disclosures about Segments of an Enterprise and Related Information*": LNG Receiving Terminal Development and Oil and Gas Exploration and Development.

### **LNG Receiving Terminal Development Business**

LNG is natural gas that, through a refrigeration process, has been reduced to a liquid state, which represents approximately 1/600th of its gaseous volume. The liquefaction of natural gas into LNG allows it to be shipped economically from areas of the world where natural gas is abundant and inexpensive to produce to other areas where natural gas demand and infrastructure exist to economically justify the use of LNG. LNG is transported using large oceangoing tankers specifically constructed for this purpose. LNG receiving terminals offload LNG from tankers, store the LNG prior to processing, heat the LNG to return it to a gaseous state and deliver the resulting natural gas into pipelines for transportation to market.

LNG is a well-established, global source of natural gas for electric generation, heating and industrial applications. According to the Groupe International des Importateurs de Gaz Naturel Liquifié, or GIIGNL, as of the end of 2004, there were 69 liquefaction plants in 12 countries capable of producing 19.2 Bcf/d and 47 receiving terminals in 13 countries capable of receiving and regasifying LNG.

North America has the largest interconnected natural gas market in the world, consuming approximately 75.7 Bcf/d in 2004, according to BP Statistical Review. Currently, there are only four onshore LNG receiving terminals in North America (excluding Puerto Rico) with a combined sustainable sendout capacity of natural gas of approximately 2.8 Bcf/d, according to GIIGNL. This regasification capacity represents about 4% of total North American current natural gas consumption. By contrast, Japan imports all of its natural gas as LNG, according to BP Statistical Review.

LNG's contribution to the North American market has historically been minimal, due mainly to an abundant supply of domestically sourced, low cost natural gas. The Energy Information Administration has reported, however, that the average wellhead price of natural gas produced in the United States has more than doubled in the last five years, an indication of a declining domestic resource base. The need to increase US regasification capacity and LNG imports to supplement natural gas supplies has been recognized in recent years. Indicative of this, the Former Chairman of the Federal Reserve testified before Congress that North America needs "to be able to adjust effectively to unexpected shortfalls in domestic supply [and that] access to world natural gas supplies will require a major expansion of LNG terminal import capacity." His successor, Ben Bernanke, said in February 2006 that "building LNG terminals is one thing that we can do and we should continue to do to create a more global market for natural gas." Also in February 2006, President Bush said that "we've got to make sure that we've got enough natural gas to meet our home heating and industrial needs. And one of the best ways to secure supply is to expand our ability to receive liquefied natural gas."

We believe that LNG is needed as a reliable source of supply to meet demand and that LNG can be delivered to North America at a competitive price. We also believe that global LNG supplies will be more than ample.

---

## Table of Contents

We began developing our LNG receiving terminal business in 1999 and, since then, have been among the first companies to secure sites and commence development of new LNG receiving terminals in the United States. We have focused our development efforts on three, 100% owned LNG receiving terminal projects at the following locations: Sabine Pass LNG in western Cameron Parish, Louisiana on the Sabine Pass Channel; Corpus Christi LNG near Corpus Christi, Texas; and Creole Trail LNG at the mouth of the Calcasieu Channel in central Cameron Parish, Louisiana. In addition, we own a 30% interest in a fourth project, Freeport LNG, located on Quintana Island near Freeport, Texas. We retained this interest following the sale of 70% of our interest in 2003 to finance our other activities.

### **Our LNG Receiving Terminals**

#### ***Sabine Pass LNG***

##### *Development*

We are developing the Sabine Pass LNG receiving terminal in western Cameron Parish, Louisiana, on the Sabine Pass Channel. We formed Sabine Pass LNG, L.P., or Sabine Pass LNG, to develop the terminal. We have entered into leases for three tracts of land comprising 853 acres in Cameron Parish, Louisiana for the project site. The initial phase, or Phase 1, of the Sabine Pass LNG receiving terminal was designed with an initial regasification capacity of 2.6 Bcf/d and three LNG storage tanks with an aggregate LNG storage capacity of 10.1 Bcfe, along with two unloading docks capable of handling 87,000 cm to 250,000 cm LNG shipping vessels. In July 2005, we made a filing with FERC seeking approval to increase the regasification capacity of the Sabine Pass LNG receiving terminal up to 4.0 Bcf/d and to add up to three additional LNG storage tanks and related facilities, which is referred to as Phase 2.

##### *Phase 1*

In March 2005, FERC issued an order authorizing Sabine Pass LNG to commence construction of Phase 1 of the Sabine Pass LNG receiving terminal. Construction began in March 2005, and we expect to commence terminal operations in 2008. In order to commence operations of Phase 1 (which is not dependent on completion of Phase 2), Sabine Pass LNG will be required to satisfy certain conditions specified by FERC.

The cost to construct Phase 1 of the Sabine Pass LNG facility is currently estimated at approximately \$900 million to \$950million, before financing costs, but including the change orders discussed below. In December 2004, we entered into a lump-sum turnkey agreement with Bechtel Corporation, or Bechtel, a major international EPC contractor, which currently requires us to pay Bechtel approximately \$712 million. Our cost estimate is subject to change due to such items as cost overruns, change orders, changes in commodity prices (particularly steel), escalation of labor costs and additional funds which may be expended to maintain our construction schedule, as described below.

In August 2005, construction at Phase 1 of our Sabine Pass LNG receiving terminal site was temporarily suspended in connection with Hurricane Katrina, as a precautionary measure. In September 2005, the terminal site was again secured and evacuated in anticipation of Hurricane Rita, the eye of which made landfall to the east of the site. No significant damage occurred to the site, equipment or materials as a result of either of these hurricanes. Construction activities were remobilized at the site and returned to pre-hurricane levels by mid-November 2005. Recent assessments from Bechtel and certain subcontractors of the hurricanes' impact indicate that, due to their residual effects, the primary impediment to our overall construction plan continues to be a shortage of available skilled labor, with likely delay of the anticipated construction schedule in the absence of remedial action. As a result, we are currently in negotiations with Bechtel and certain subcontractors concerning additional activities and expenditures in order, among other things, to attract sufficient skilled labor to mitigate potential schedule delays and still provide a reasonable opportunity to attain the initial target bonus date of April 3, 2008 (the date originally anticipated for completion of construction sufficient to achieve a sendout rate of at least 2.0 Bcf/d for a minimum sustained test period of 24 hours and that, if attained, would

---

## Table of Contents

entitle Bechtel to a scheduled \$12 million bonus). As part of these negotiations, we have agreed in principle to defer the date by which substantial completion of the entire project is required to be accomplished under the EPC contract from September 3 to December 20, 2008. In the absence of substantial completion by such date, Bechtel would be obligated to pay us certain liquidated damages as provided under the terms of the EPC contract. We expect that the above-described arrangement will not exceed \$50 million, although such amount is subject to change, requires approval of the lenders under our Sabine Pass Credit Facility (as described below under “—Funding”) and requires that a change order be agreed upon with Bechtel.

### *Phase 2*

Phase 2 of our Sabine Pass LNG facility may be constructed in stages. It is expected that the initial stage will consist of two LNG storage tanks, additional vaporizers and related facilities to increase the total regasification capacity to 4.0 Bcf/d. This stage is estimated to cost approximately \$500 million to \$550 million, before financing costs. In a subsequent stage still under evaluation, we may add a sixth LNG storage tank and related facilities. We currently anticipate that Phase 2 will be constructed under a reimbursable engineering, procurement, construction and management agreement currently under negotiation with Bechtel pursuant to which Bechtel would manage, on behalf of Sabine Pass LNG, the construction activities of other contractors under agreements currently being negotiated between Sabine Pass LNG and those contractors. Our cost estimate is subject to change due to such items as cost overruns, change orders, changes in commodity prices (particularly steel) and escalating labor costs.

Subject to our receipt of the required regulatory governmental approvals, including FERC approval, and acceptable funding arrangements, which may include existing cash balances, proceeds from debt or equity offerings, or a combination thereof, we anticipate beginning construction of the first stage of Phase 2 during the second quarter of 2006. Assuming we achieve this schedule, we anticipate that Phase 2 operations would commence in 2009. In order to commence such operations, we will be required to satisfy certain conditions specified by FERC.

### *Customers*

#### *Total TUA*

In September 2004, Sabine Pass LNG entered into a TUA with Total LNG USA, Inc., or Total, to provide berthing for LNG tankers and for the unloading, storage and regasification of LNG at the LNG receiving terminal. Sabine Pass LNG has no obligation to provide Total with certain services such as (i) harbor, mooring and escort services for LNG tankers, including the provision of tugboats, (ii) the transportation of natural gas downstream from the LNG terminal or the construction of any pipelines to provide such transportation or (iii) the marketing of natural gas.

Under the TUA, Total has reserved 390,915,000 MMBtu of annual LNG receipt capacity, which is equivalent to approximately 1.0 Bcf/d of regasification capacity, assuming an energy content of 1.05 MMBtu per Mcf and retainage of 2%. The Total TUA is scheduled to commence no later than April 2009, subject to substantial completion, runs for an initial term of 20 years and is subject to six additional 10-year extensions. Beginning on the commercial start date of the Sabine Pass LNG facility, Total has agreed to pay a monthly fixed capacity reservation fee of \$9.1 million; a monthly operating fee of \$1.3 million, which is adjusted annually for changes in the U.S. Consumer Price Index (All Urban Consumers); and certain other incremental costs and governmental authority taxes and costs. These monthly payment amounts are equivalent to payments of \$0.28 per MMBtu for capacity and \$0.04 per MMBtu for operating fees, respectively, of reserved monthly LNG receipt capacity. In addition, each month Sabine Pass LNG is entitled to retain 2% of the LNG delivered for Total's account for use as fuel at the facility. Total's obligations under the TUA are supported by an irrevocable guarantee, for an amount up to \$2.5 billion, in favor of Sabine Pass LNG by Total S.A.

If any governmental authority (i) imposes any taxes on Sabine Pass LNG (excluding taxes on revenue or income) with respect to the services provided under the TUA, or the LNG receiving terminal or (ii) enacts any



---

## Table of Contents

safety or security related regulation which materially increases the costs of Sabine Pass LNG in relation to the services provided or the LNG receiving terminal, Total will bear such taxes or increased regulatory costs at the rate of 40%, subject to adjustment if the LNG regasification facilities are expanded. To the extent any ad valorem taxes are imposed and not abated, we will reimburse Total for up to one-half of such amount not to exceed \$3.9 million per year.

Sabine Pass LNG is obligated to pay liquidated damages to Total in the event of certain types of docking and unloading delays.

Both Sabine Pass LNG and Total may assign their interests under the TUA to affiliates, and, as permitted by the TUA and discussed below under “—Funding,” Sabine Pass LNG has pledged its interest under the TUA to lenders to secure indebtedness incurred to finance the construction and term financing of the LNG receiving terminal. In addition, Total may make a partial assignment of its total reserved regasification capacity to nonaffiliates provided that (i) the assignee agrees to be bound by the TUA, (ii) the parent guarantee continues to apply to all assigned obligations and (iii) Total and the assignee designate a representative and jointly exercise all rights under the TUA.

Total may terminate the TUA if:

- Sabine Pass LNG has declared *force majeure* with respect to a period that has extended, or is projected to extend, for 18 months; or
- for reasons not excused by *force majeure* or Total’s actions, if Sabine Pass LNG:
  - fails to deliver at least 191,625,000 MMBtu of Total’s total natural gas nominations in a 12-month period;
  - fails entirely to receive at least 15 cargoes nominated by Total over a period of 90 consecutive days; or
  - fails to unload 50 cargoes or more scheduled for delivery by Total for a 12-month period.

Sabine Pass LNG may terminate the TUA if:

- the parent guarantee ceases to be in full force and effect;
- for a period exceeding 15 days, two of the parent guarantor’s credit ratings fall below investment grade; or
- the parent guarantor commences bankruptcy or liquidation proceedings, or has such proceedings commenced against it.

Either party may terminate the TUA with 30 days written notice if (i) a party has failed to pay when due an amount owed that causes its cumulative delinquency to exceed three times the monthly capacity reservation fee, (ii) the cumulative delinquency has not been paid within 60 days of such notice and (iii) the other party has subsequently given 30 days’ written notice to terminate the TUA.

In November 2004, Total exercised its option to proceed with the transaction by delivering to Sabine Pass LNG an advance capacity reservation fee payment of \$10 million and a guarantee by its parent entity, Total S.A., of certain Total obligations under the TUA. Because Total elected to proceed with the transaction and Bechtel accepted the final notice to proceed, or NTP, an additional advance capacity reservation fee payment of \$10 million was paid by Total to Sabine Pass LNG in April 2005.

Cheniere, Sabine Pass LNG and Total also entered into an omnibus agreement in September 2004, under which the TUA remains subject to certain conditions. Under the omnibus agreement, if Sabine Pass LNG enters into a new TUA with a third party, other than our affiliates, for capacity of 50 MMcf/d or more, with a term of

---

## Table of Contents

five years or more, prior to the commercial start date of the terminal, Total will have the option, exercisable within 30 days of the receipt of notice of such transaction, to adopt the pricing terms contained in such new TUA for the remainder of the term of the Total TUA. In addition, the omnibus agreement provided Total with an option to increase its reserved capacity in the event that either party provided notice of a plan to expand the Sabine Pass LNG facility. During 2005, we provided such notice to Total and its option expired.

### *Chevron USA TUA*

In November 2004, Sabine Pass LNG entered into a TUA with Chevron USA, Inc., or Chevron USA, pursuant to which Sabine Pass LNG is obligated to provide berthing for LNG tankers and for the unloading, storage and regasification of LNG at the LNG receiving terminal. Sabine Pass LNG has no obligation to provide certain services such as (i) harbor, mooring and escort services for LNG tankers, including the provision of tugboats, (ii) the transportation of natural gas downstream from the LNG terminal or the construction of any pipelines to provide such transportation or (iii) the marketing of natural gas.

In December 2005, Chevron USA exercised its option under its omnibus agreement to increase its regasification capacity by 300 MMcf/d for a total of 1.0 Bcf/d and paid Sabine Pass LNG an additional \$3 million advance capacity reservation fee. As a result of Chevron USA exercising its option, the TUA is being amended to reflect such increased reservation of regasification capacity. Under the TUA, before the amendment described above, Chevron USA had reserved 282,761,850 MMBtu of annual LNG receipt capacity, which is equivalent to approximately 700 MMcf/d of regasification capacity, assuming an energy content of 1.085 MMBtu per Mcf and retainage of 2%.

The Chevron USA TUA commences between February 2009 and July 2009, subject to substantial completion, runs for an initial term of 20 years and is subject to two additional 10-year extensions. Beginning on the commercial start date of the Sabine Pass LNG facility, Chevron USA is required to pay Sabine Pass LNG a fixed monthly fee for this regasification capacity that is comprised of (i) a reservation fee of \$0.28 per MMBtu of one-twelfth of the reserved annual LNG receipt capacity, (ii) an operating fee of \$0.04 per MMBtu of one-twelfth of the reserved annual LNG receipt capacity and (iii) certain taxes and regulatory costs. The operating fee is adjusted annually for changes in the U.S. Consumer Price Index (All Urban Consumers). In addition, each month Sabine Pass LNG is entitled to retain 2% of the LNG delivered for Chevron USA's account for use as fuel at the facility. Chevron Corporation, or Chevron, will be required to guarantee Chevron USA's payment obligations under the TUA, up to a maximum of 80% of the fees payable under the TUA.

If any governmental authority (i) imposes any taxes on Sabine Pass LNG (excluding taxes on revenue or income) with respect to the services provided under the TUA, or the LNG receiving terminal or (ii) enacts any safety or security related regulation which materially increases the costs of Sabine Pass LNG in relation to the services provided at the LNG receiving terminal, Chevron USA will bear a proportionate share of such taxes or increased regulatory costs equal to 28%, subject to adjustment for Chevron USA's exercise of its capacity option in December 2005.

Sabine Pass LNG is obligated to pay liquidated damages to Chevron USA in the event of certain types of docking and unloading delays.

Both Sabine Pass LNG and Chevron USA may assign their interests under the TUA to affiliates, and, as permitted by the TUA and discussed below under "—Funding," Sabine Pass LNG has pledged its interest under the TUA to lenders to secure indebtedness incurred to finance the construction and term financing of the LNG receiving terminal. In addition, Chevron USA may make a partial assignment of its total reserved regasification capacity to nonaffiliates provided (i) the assignee agrees to be bound by the TUA, (ii) the parent guarantee continues to apply to all assigned obligations, (iii) Chevron USA remains liable for payments owed and (iv) the respective responsibilities of the parties under the TUA are not increased or decreased.

An assignment under the TUA will terminate Chevron USA's or Sabine Pass LNG's obligations only if (i) the assignment constitutes all of such party's rights and obligations under the TUA, (ii) the assignee agrees to

---

## Table of Contents

be bound by the TUA and (iii) the assignee demonstrates creditworthiness at the time of the assignment that is the same or better than the guarantor, in the case of Chevron USA, or Sabine Pass LNG, in its case.

Chevron USA may terminate the TUA if Sabine Pass LNG has declared *force majeure* with respect to a period that has extended, or is projected to extend, for 18 months, or for reasons not excused by *force majeure* or Chevron USA's actions, if Sabine Pass LNG:

- fails to deliver at least 141,380,925 MMBtu of Chevron USA's total natural gas nominations in a 12-month period;
- fails entirely to receive 12 cargoes or more nominated by Chevron USA over a period of 90 days; or
- fails to unload, or notifies Chevron USA that it would be unable to unload, 37 cargoes or more scheduled for delivery by Chevron USA for a 12-month period.

The foregoing amounts are subject to adjustment in connection with the pending amendment of the TUA as a result of Chevron USA's December 2005 exercise of its capacity option.

Sabine Pass LNG may terminate the TUA if the parent guarantee ceases to be in full force and effect or if the parent guarantor or Chevron USA commences bankruptcy, insolvency or liquidation proceedings, or has such proceedings commenced against it, that are not stayed within 60 days.

Either party may terminate the TUA with 30 days written notice if (i) a party has failed to pay when due an amount owed that causes its cumulative delinquency to exceed three times the monthly capacity reservation fee, (ii) the cumulative delinquency has not been paid within 60 days after issuance of a delinquency notice and (iii) the other party has subsequently given 30 days written notice to terminate the TUA.

Cheniere, Sabine Pass LNG and Chevron USA simultaneously entered into an omnibus agreement, under which Chevron USA agreed to make advance capacity reservation fee payments. Under the omnibus agreement, Chevron USA exercised an option in December 2005, at the same fee, to increase its reserved capacity to 1.0 Bcf/d. As a result, a total of \$20 million of advance capacity reservation fee payments were paid to Sabine Pass LNG by Chevron USA under the omnibus agreement. In addition, the omnibus agreement provided Chevron USA with an option to increase its reserved capacity in the event that either party provided notice of a plan to expand the Sabine Pass LNG facility. During 2005, we provided such notice to Chevron USA and its option expired.

### *Cheniere LNG Marketing*

Cheniere LNG Marketing, Inc., or Cheniere Marketing, our wholly-owned subsidiary, intends to enter into a TUA with Sabine Pass LNG for 1.5 Bcf/d of regasification capacity at our Sabine Pass LNG receiving terminal, which capacity will be reduced to 600 MMcf/d in the event that both the Total TUA and the Chevron USA TUA commence prior to the completion of Phase 2 of our Sabine Pass LNG facility. See "—LNG and Natural Gas Marketing Business" for a discussion of our regasification capacity expected to be utilized by Cheniere Marketing.

### *Proposed Capacity Offering*

Sabine Pass LNG intends to conduct a formal request-for-proposal process with unaffiliated third parties for up to 500 MMcf/d of regasification capacity at the Sabine Pass LNG receiving terminal. This process is expected to commence in April 2006 and will be subject to prior commitment to qualified third parties. We expect the request-for-proposal period to conclude in the second quarter of 2006; however, we may not be able to obtain any TUAs on terms acceptable to us, or at all.

### *EPC Agreement*

In December 2004, Sabine Pass LNG entered into a lump-sum turnkey EPC agreement with Bechtel for the construction of Phase 1 of the Sabine Pass LNG receiving terminal. Under the EPC agreement, Bechtel agreed to

---

## Table of Contents

provide Sabine Pass LNG with services for the engineering, procurement and construction of the Sabine Pass LNG receiving, storage and regasification terminal. Except for certain specified third-party work specified in the EPC agreement, the work to be performed by Bechtel includes all of the work required to achieve substantial completion and final completion of the Sabine Pass LNG receiving terminal in accordance with the requirements of the EPC agreement, including achieving specified minimum acceptance criteria and performance guarantees. Bechtel is obligated to perform its work in accordance with good engineering and construction practices and applicable laws, codes and standards.

Sabine Pass LNG issued a limited notice to proceed, or LNTP, in December 2004 and a final notice to proceed, or NTP, in early April 2005, which required Bechtel to commence all other aspects of the work under the EPC agreement. Bechtel must achieve substantial completion in accordance with the requirements of the EPC agreement on or before September 3, 2008. Final completion must be attained no later than 90 days after achieving substantial completion.

Until substantial completion under the terms of the EPC agreement, Sabine Pass LNG has certain rights to request change orders, and Bechtel has the right to request change orders up to and after substantial completion in the event of specified occurrences, including, among other things:

- a *force majeure* event;
- a suspension of work ordered by Sabine Pass LNG;
- certain acts and omissions by Sabine Pass LNG (including failure to fulfill obligations), but, in each case, only where such act or omission adversely affects Bechtel's costs of the performance of work, its ability to perform the work in accordance with the project schedule or its ability to perform any material obligation under the EPC agreement; and
- certain changes in law, but only where such delay adversely affects Bechtel's costs of the performance of the work, its ability to perform the work in accordance with the project schedule or its ability to perform any material obligation under the EPC agreement.

Sabine Pass LNG agreed to pay to Bechtel a contract price of \$646.9 million plus certain reimbursable costs for the work under the EPC agreement. This contract price is subject to adjustment for changes in certain commodity prices, contingencies, change orders and other items. Payments under the EPC agreement will be made in accordance with the payment schedule set forth in the EPC agreement. The contract price and payment schedule, including milestones, may be amended only by change order. Bechtel will be liable to Sabine Pass LNG for certain delays in achieving substantial completion, minimum acceptance criteria and performance guarantees. Bechtel will be entitled to a scheduled bonus of \$12 million, or a lesser amount in certain cases, if on or before April 3, 2008, Bechtel completes construction sufficient to achieve, among other requirements specified in the EPC agreement, a sendout rate of at least 2.0 Bcf/d for a minimum sustained test period of 24 hours. Bechtel will be entitled to receive an additional bonus of \$67,000 per day (up to a maximum of \$6 million) for each day that commercial operation is achieved prior to April 1, 2008. As of February 28, 2006, change orders for \$64.8 million had been approved, increasing the total contract price to \$711.8 million. We anticipate additional change orders intended to mitigate ongoing effects of the 2005 hurricanes that would increase the contract price by an amount not expected to exceed \$50 million. We expect to submit any such change orders to our lenders by May 3, 2006 for approval under the Sabine Pass Credit Facility described below under "—Funding".

Bechtel warrants in the EPC agreement that:

- the equipment required for the Sabine Pass LNG receiving terminal will be new and of good quality;
- the work and the equipment will meet the requirements of the EPC agreement, including good engineering and construction practices and applicable laws, codes and standards; and
- the work and the equipment will be free from encumbrances to title.

Until 18 months after substantial completion, Bechtel will be liable to promptly correct any work that is found defective.

---

## Table of Contents

In the event of an uncured default by Bechtel, Sabine Pass LNG may terminate the EPC agreement and take any of the following actions:

- take possession of the facility, equipment, construction equipment, work product and books and records;
- take assignment of certain subcontracts; and
- complete the work.

Following such a termination, if the cost to reach final completion exceeded the unpaid balance of the contract price, Bechtel would be liable for the difference. If the cost to reach final completion were less than the unpaid balance of the contract price, the difference would be payable to Bechtel.

Sabine Pass LNG also has the right to terminate the EPC agreement for convenience. In the event of any such termination for convenience, Bechtel would be paid:

- the portion of the contract price for the work performed prior to termination, less that portion of the contract price paid previously;
- actual reasonable cancellation charges owed by Bechtel to subcontractors (if Sabine Pass LNG does not take assignment of such subcontracts);
- actual costs associated with demobilization charges; and
- lost profits, except in certain cases, equal to 10% of the contract price less a portion of the advance payment related to the NTP.

Sabine Pass LNG may, upon a 30-day written notice to Bechtel, suspend the work under the EPC agreement. In the event of such suspension for a period exceeding 90 consecutive days or 120 aggregate days, other than any suspension due to an event of *force majeure* or the fault or negligence of Bechtel or its subcontractors, Bechtel would be permitted to terminate the EPC agreement subject to giving a 14 days' notice. In the event of such a termination, Bechtel would be entitled to the compensation described above in relation to termination for convenience. If Sabine Pass LNG suspends work under the EPC agreement, Bechtel could be entitled to a change order to recover the reasonable costs of the suspension, including demobilization and remobilization costs. Bechtel may also suspend or terminate the EPC agreement upon the occurrence of certain other events, including *force majeure* and uncured defaults of Sabine Pass LNG such as:

- failure to pay any undisputed amounts;
- failure to comply materially with material obligations under the EPC agreement; and
- insolvency.

Under the EPC agreement, if Bechtel experiences a *force majeure* event, it could be entitled to an extension of the date by which substantial completion is to be accomplished and an extension of the date by which it could earn the \$12 million bonus. If any *force majeure* delay lasts at least 30 days, Bechtel would be entitled to an adjustment of the contract price under the EPC agreement to compensate it for its standby expenses, up to a limit of \$3.8 million in the aggregate. A *force majeure* event generally occurs if any act or event occurs that:

- prevents or delays the affected party's performance of its obligations in accordance with the terms of the EPC agreement;
- is beyond the reasonable control of the affected party, not due to its fault or negligence; and
- could not have been prevented or avoided by the affected party through the exercise of due diligence.

Bechtel has claimed events of *force majeure* arising out of three hurricanes that made landfall along the U.S. Gulf Coast in 2005. Sabine Pass LNG is currently in negotiations with Bechtel and certain subcontractors concerning additional activities and expenditures in order, among other things, to attract sufficient skilled labor

---

## Table of Contents

to mitigate potential schedule delays and provide a reasonable opportunity for Bechtel to attain the initial target bonus date of April 3, 2008 (the date originally anticipated for completion of construction sufficient to achieve a sendout rate of at least 2.0 Bcf/d for a minimum sustained test period of 24 hours and that, if attained, would entitle Bechtel to a scheduled \$12 million bonus). As part of these negotiations, we have agreed in principle to defer the date by which substantial completion of the entire project is required to be accomplished under the EPC contract from September 3 to December 20, 2008. In the absence of substantial completion by such date, Bechtel would be obligated to pay us certain liquidated damages as provided under the terms of the contract. We expect that the above-described arrangement will not exceed \$50 million, although such amount is subject to change, requires approval of the lenders under our Sabine Pass Credit Facility (as described below under “—Funding”) and requires that a change order be agreed upon with Bechtel.

### *Operation*

In February 2005, Sabine Pass LNG entered into an Operation and Maintenance Agreement, or O&M Agreement, with Cheniere LNG O&M Services, L.P., or Cheniere O&M, a wholly-owned subsidiary of Cheniere. Pursuant to the O&M Agreement, Cheniere O&M has agreed to provide all necessary services required to operate and maintain the Sabine Pass LNG receiving terminal. The O&M Agreement will remain in effect until 20 years after substantial completion of the facility. Prior to substantial completion of the project, Sabine Pass LNG is required to reimburse Cheniere O&M for its operating expenses and pay a fixed monthly fee of \$95,000 (indexed for inflation). The fixed monthly fee will increase to \$130,000 (indexed for inflation) upon substantial completion of the facility, and Cheniere O&M will thereafter in certain circumstances be entitled to a bonus equal to 50% of the salary component of labor costs.

In February 2005, Sabine Pass LNG also entered into a Management Services Agreement, or MSA, with Sabine Pass LNG-GP, Inc., or Sabine Pass GP, its general partner and a wholly-owned subsidiary of Cheniere. Pursuant to the MSA, Sabine Pass LNG appointed Sabine Pass GP to manage the business of Sabine Pass LNG, excluding those matters provided under the O&M Agreement. The MSA terminates 20 years after the commercial start date set forth in the Total TUA. Prior to substantial completion of construction of the Sabine Pass LNG receiving facility, Sabine Pass LNG is required to pay Sabine Pass GP a monthly fixed fee of \$340,000; thereafter, the monthly fixed fee will increase to \$520,000 (indexed for inflation).

### *Funding*

In February 2005, Sabine Pass LNG entered into an \$822 million credit facility, or Sabine Pass Credit Facility, with an initial syndicate of 47 financial institutions. Société Générale serves as the administrative agent and HSBC Bank USA, National Association, or HSBC, serves as collateral agent. The Sabine Pass Credit Facility will be used to fund a substantial majority of the costs of constructing and placing into operation Phase 1 of the Sabine Pass LNG receiving terminal. Unless Sabine Pass LNG decides to terminate availability earlier, the Sabine Pass Credit Facility will be available until no later than April 1, 2009, after which time any unutilized portion of the Sabine Pass Credit Facility will be permanently canceled. Before Sabine Pass LNG could make an initial borrowing under the Sabine Pass Credit Facility, it was required to provide evidence that it had received equity contributions in amounts sufficient to fund \$233.7 million of the project costs. As of December 31, 2005, the \$233.7 million equity contributions had been funded and, as a result, we began drawing under the Sabine Pass Credit Facility in January 2006. As of February 28, 2006, \$58.5 million had been drawn under the Sabine Pass Credit Facility. In addition, we made a \$37.4 million subordinated loan to Sabine Pass LNG in late 2005.

Borrowings under the Sabine Pass Credit Facility bear interest at a variable rate equal to LIBOR plus the applicable margin. The applicable margin varies from 1.25% to 1.625% during the term of the Sabine Pass Credit Facility. The Sabine Pass Credit Facility provides for a commitment fee of 0.50% per annum on the daily committed, undrawn portion of the Sabine Pass Credit Facility. Administrative fees must also be paid annually to the administrative agent and the collateral agent. The principal of loans made under the Sabine Pass Credit Facility must be repaid in semi-annual installments commencing six months after the later of (i) the date that

---

## **Table of Contents**

substantial completion of the project occurs under the EPC agreement and (ii) the commercial start date under the Total TUA. Sabine Pass LNG may specify an earlier date to commence repayment upon satisfaction of certain conditions. In any event, payments under the Sabine Pass Credit Facility must commence no later than October 1, 2009, and all obligations under the Sabine Pass Credit Facility mature and must be fully repaid by February 25, 2015.

The Sabine Pass Credit Facility contains customary conditions precedent to the initial borrowing and any subsequent borrowings, as well as customary affirmative and negative covenants. Sabine Pass LNG has obtained, and may in the future seek, consents, waivers and amendments to the Sabine Pass Credit Facility documents. The obligations of Sabine Pass LNG under the Sabine Pass Credit Facility are secured by all of Sabine Pass LNG's personal property, including the Total and Chevron USA TUAs and the partnership interests in Sabine Pass LNG.

In connection with the closing of the Sabine Pass Credit Facility, Sabine Pass LNG entered into swap agreements with HSBC and Société Générale. Under the terms of the swap agreements, Sabine Pass LNG will be able to hedge against rising interest rates, to a certain extent, with respect to its drawings under the Sabine Pass Credit Facility up to a maximum amount of \$700 million. The swap agreements have the effect of fixing the LIBOR component of the interest rate payable under the Sabine Pass Credit Facility with respect to hedged drawings under the Sabine Pass Credit Facility up to a maximum of \$700 million at 4.49% from July 25, 2005 to March 25, 2009 and at 4.98% from March 26, 2009 through March 25, 2012. The final termination date of the swap agreements will be March 25, 2012.

We are currently evaluating funding alternatives for the construction of Phase 2 of the Sabine Pass LNG facility, which may include existing cash balances, proceeds from debt or equity offerings, or a combination thereof.

### ***Corpus Christi LNG***

#### ***Development***

We are also developing the Corpus Christi LNG receiving terminal near Corpus Christi, Texas. We formed Corpus Christi LNG, L.P., or Corpus Christi LNG, in May 2003 to develop the terminal. We contributed our technical expertise and know-how, and all of the work in progress related to the Corpus Christi project, in exchange for a 66.7% limited partner interest in Corpus Christi LNG. A third party, BPU LNG, Inc., or BPU LNG, contributed approximately 212 acres of land and committed to contribute cash to fund the first \$4.5 million of Corpus Christi LNG project expenses, in exchange for its 33.3% limited partner interest. Corpus Christi LNG also obtained related easements and other rights to an additional 400 acres. In January 2004, BPU LNG entered into an option agreement with Corpus Christi LNG to acquire 100 MMcf/d of regasification capacity at the terminal, which was subsequently assigned to its sole stockholder, BPU Associates, LLC. In February 2005, we acquired BPU LNG's 33.3% limited partner interest in exchange for two million restricted shares of Cheniere common stock, which were subsequently registered for resale.

The Corpus Christi LNG receiving terminal is designed with regasification capacity of 2.6 Bcf/d, two docks and three LNG storage tanks with an aggregate LNG storage capacity of 10.1 Bcfe. The facility will have two unloading docks, which can handle 87,000 cm to 250,000 cm LNG shipping vessels. The total cost to construct this facility is currently estimated at approximately \$650 million to \$750 million, before financing costs. This estimate is based in part on our negotiations with a major international EPC contractor. Our cost estimate is subject to change due to such items as cost overruns, change orders, changes in commodity prices (particularly steel) and escalating labor costs. BPU LNG was required to fund 100% of the first \$4.5 million of Corpus Christi LNG's expenditures, which amount was funded as of March 31, 2004. From that date until February 8, 2005, when we acquired BPU LNG's 33.3% interest, we funded 66.7% of the expenditures of Corpus Christi LNG, with BPU LNG funding the balance. Since February 8, 2005, BPU LNG has not been required to fund any expenditures, and as the sole owner of Corpus Christi LNG, we are now required to fund 100% of the expenditures.

---

## **Table of Contents**

In December 2005, FERC issued an order authorizing Corpus Christi LNG to commence initial construction of the Corpus Christi LNG receiving terminal, subject to satisfaction of certain conditions specified by FERC. We are negotiating and anticipate entering into an arrangement with a major international EPC contractor for the Corpus Christi LNG receiving terminal. We expect to begin site preparation and detailed engineering work in the second quarter of 2006 and to commence operations at the Corpus Christi LNG receiving terminal in early 2010.

### *Customers*

Cheniere Marketing intends to enter into a TUA with Corpus Christi LNG for 1.0 Bcf/d of regasification capacity at that terminal. See “—LNG and Natural Gas Marketing Business” for a discussion of our regasification capacity expected to be utilized by Cheniere Marketing.

Corpus Christi LNG intends to conduct a formal request-for-proposal process with unaffiliated third parties for up to 1.0 Bcf/d of regasification capacity at the Corpus Christi LNG receiving terminal. This process, a time for which has not been established, will be subject to prior commitment to qualified third parties. However, we may not be able to obtain any TUAs on terms acceptable to us, or at all.

### *Funding*

We currently expect to fund the project costs for our Corpus Christi LNG receiving terminal using financing similar to that used for our Sabine Pass LNG facility, proceeds from debt or equity offerings, existing cash or a combination thereof.

## **Creole Trail LNG**

### *Development*

We are also developing an LNG receiving terminal at the mouth of the Calcasieu Channel in central Cameron Parish, Louisiana. We formed Creole Trail LNG, L.P., or Creole Trail LNG, in December 2004 to develop the terminal. We have options to lease tracts of land comprising 1,463 acres in Cameron Parish, Louisiana for the project site.

The Creole Trail LNG receiving terminal is anticipated to be designed with regasification capacity of 3.3 Bcf/d, two docks and four LNG storage tanks with an aggregate LNG storage capacity of 13.5 Bcfe. The facility will have two unloading docks, which can handle 87,000 cm to 250,000 cm LNG shipping vessels. The cost to construct the Creole Trail facility is currently estimated at approximately \$850 million to \$950 million, before financing costs. Our cost estimate is preliminary and is subject to change.

In May 2005, we filed an application with FERC to obtain an order to site, construct and operate the facility. In December 2005, FERC issued the DEIS for our Creole Trail facility, preliminarily concluding that the facility, with appropriate mitigating measures as recommended, would have limited adverse environmental impact. Once we obtain FERC authorization, we expect to begin construction in 2007 after obtaining financing and entering into an EPC agreement. Based on this schedule, we expect to commence terminal operations in 2011.

### *Customers*

We have not entered into any contracts for the regasification capacity at our proposed Creole Trail LNG receiving terminal. We anticipate reserving the regasification capacity at our Creole Trail LNG receiving terminal for strategic relationships. We may not be able to obtain any TUAs on terms acceptable to us, or at all. We currently intend that a portion of the regasification capacity not committed to unaffiliated third parties will be contracted to Cheniere Marketing. See “—LNG and Natural Gas Marketing Business” for a discussion of our regasification capacity expected to be utilized by Cheniere Marketing.



---

## **Table of Contents**

### *Funding*

We currently expect to fund the costs of the Creole Trail LNG terminal project using financing similar to that used for our Sabine Pass LNG facility, proceeds from future debt or equity offerings, existing cash or a combination thereof.

### *Other Sites*

We continue to evaluate, and may develop, additional sites that we believe may be commercially desirable locations for LNG receiving terminals.

## **Other LNG Interests—Freeport LNG**

### *Development*

In 2001, we initiated development of an LNG receiving facility on Quintana Island near Freeport, Texas. In 2003, we contributed to Freeport LNG Development, L.P., or Freeport LNG, all of our interest in the Freeport site and project in exchange for a 40% limited partner interest in Freeport LNG and \$6.7 million of cash payments. We subsequently sold a 10% limited partner interest in Freeport LNG to an affiliate of Contango Oil & Gas Company. As a result of the sale, we own a 30% limited partner interest in Freeport LNG. As a limited partner in Freeport LNG, we must rely largely on the general partner to successfully implement Freeport LNG's business plans.

The Freeport LNG receiving terminal is being developed on land leased from Port Freeport. The initial phase of the project includes regasification capacity of 1.5 Bcf/d, one dock, two LNG storage tanks with an aggregate LNG storage capacity of 6.7 Bcfe, and a 9.4-mile, 42-inch diameter pipeline through which natural gas will be transported to a customer redelivery point at Stratton Ridge, Texas, which is a major point of interconnection with the Texas intrastate gas pipeline grid. We have been advised by Freeport LNG that it has entered into a lump-sum turnkey contract for its receiving terminal, and that the estimated cost to construct the terminal and associated facilities (before the proposed expansion discussed below) is approximately \$800 million to \$850 million, before financing costs. We believe that this cost estimate is subject to change due to such items as cost overruns and change orders under the EPC agreement.

In January 2005, FERC authorized Freeport LNG to commence construction of the LNG receiving terminal and natural gas pipeline. Construction began in the first quarter of 2005, and we expect that terminal operations will commence in early 2008. In order to commence operations, Freeport LNG will be required to satisfy certain conditions specified by FERC.

Freeport LNG has filed an application seeking an additional order from FERC to authorize the construction of an expansion that would increase the regasification capacity from its currently permitted 1.5 Bcf/d LNG receiving terminal to approximately 4.0 Bcf/d. In addition to increased regasification capacity, the proposed expansion includes a second dock, a third LNG storage tank and 7.5 Bcf of underground salt cavern gas storage. The development, construction and operation of the Freeport LNG facility, as well as the anticipated financial consequences for us as a limited partner in Freeport LNG, will change as a result of any such expansion.

### *TUA Customers*

Freeport LNG has entered into TUAs with three customers: The Dow Chemical Company, or Dow, ConocoPhillips Company, or ConocoPhillips, and MC Global Gas Corporation, or MC Global, a wholly-owned subsidiary of Mitsubishi Corporation. Under the TUAs, Freeport LNG is obligated to provide berthing for LNG tankers and for the unloading, storage and regasification of LNG at its receiving terminal. In addition, Freeport LNG will provide for the transportation and delivery of natural gas through the facility's 9.4-mile pipeline to Stratton Ridge, Texas for interconnection with downstream pipelines.

---

## Table of Contents

In March 2004, Dow entered into a long-term TUA with Freeport LNG, pursuant to which Dow has reserved 195,275,000 MMBtu of annual LNG receipt capacity under the TUA, which is equivalent to approximately 500 MMcf/d of regasification capacity. The Dow TUA commences between April 2007 and March 2008 (subject to extensions), runs for an initial term of 20 years and is subject to three 10-year extensions. Dow is required to pay Freeport LNG a monthly reservation fee for this regasification capacity, which is subject to reduction under certain circumstances. In addition, each month Freeport LNG is entitled to retain a percentage of Dow's share of LNG to be used as fuel at the facility. Dow is also required to pay a portion of power and other operating costs.

In July 2004, ConocoPhillips and Freeport LNG entered into a long-term TUA, pursuant to which ConocoPhillips has reserved 390,550,000 MMBtu of annual LNG receipt capacity, which is equivalent to approximately 1.0 Bcf/d of regasification capacity. In addition, ConocoPhillips has exercised its option to reserve approximately 300 MMcf/d of regasification capacity with respect to the additional capacity resulting from the proposed expansion. The ConocoPhillips TUA commences between April 2007 and March 2008 (subject to extensions), runs for an initial term until February 2033 and is subject to six 10-year extensions. ConocoPhillips is required to pay Freeport LNG a monthly reservation fee for this regasification capacity, which is subject to reduction under certain circumstances. In addition, each month Freeport LNG is entitled to retain ConocoPhillips' allocable share of LNG used as fuel at the facility and its allocable portion of all other actual losses. ConocoPhillips is also required to pay on a monthly basis its allocable portion of power and other operating costs.

In January 2005, Freeport LNG announced that it had executed a 17-year TUA with MC Global. Pursuant to the TUA, MC Global has reserved approximately 150 MMcf/d of regasification capacity in the Freeport LNG terminal and has an option to increase its total regasification capacity by an additional 100 MMcf/d, to a total of 250 MMcf/d.

### ***Funding***

In July 2004, Freeport LNG entered into a credit agreement with ConocoPhillips for ConocoPhillips to provide a substantial majority of the debt financing for the initial phase of the project. In December 2005, Freeport LNG announced that it had closed a \$383 million private placement of notes, which will be used to fund the remaining portion of the initial phase of the project, a portion of the cost of expanding the LNG receiving terminal and the development of 7.5 Bcf of underground salt cavern gas storage. As a result of such financing being obtained, we do not anticipate that any capital calls will be made upon the limited partners of Freeport LNG in the foreseeable future.

To the extent that the funding provided by ConocoPhillips and the private placement notes is insufficient or not available to meet the capital expenditures or working capital requirements of Freeport LNG, the general partner of Freeport LNG may obtain such additional funding from various funding sources. Under the limited partnership agreement of Freeport LNG, development expenses of the Freeport LNG project and other Freeport LNG cash needs generally are to be funded out of Freeport LNG's own cash flows, borrowings or other sources, and with capital contributions by the limited partners. We received capital calls, and made capital contributions, in the amount of approximately \$2.1 million in 2005. No capital calls are currently outstanding, and in view of the closing of the Freeport LNG financing described above, we do not anticipate any in the foreseeable future. However, in the event of any future capital call, we will have the option either to contribute the requested capital or to decline to contribute. If we decline to contribute, the other limited partners could elect to make our contribution and receive back twice the amount contributed on our behalf, without interest, before any Freeport LNG cash flows are otherwise distributed to us. We currently expect to evaluate any future Freeport LNG capital calls on a case-by-case basis and to fund additional capital contributions that we elect to make using cash on hand and funds raised through the issuance of Cheniere equity or debt securities or other Cheniere borrowings.

The general partner of Freeport LNG is also authorized to do all things necessary to obtain debt and equity financing in connection with any expansion of the facility. Any equity financing obtained for such expansion will

---

## Table of Contents

dilute the ownership interests of the limited partners on a pro rata basis. However, we and the other limited partners have preemptive rights that allow any limited partner to maintain its percentage ownership interest in Freeport LNG.

### **Competition**

The volume of natural gas supply additions required to meet U.S. consumption needs is a function of not only demand growth but also the decline in the underlying production base. In North America, this natural decline has been accelerating over the last decade, significantly increasing the need to bring on new supplies. According to a 2003 report by The National Petroleum Council, the natural gas production from existing wells in the United States in 1991 declined 17%, or 9.0 Bcf/d, by 1992. In contrast, data from IHS Energy shows that natural gas production from existing wells in 2004 declined 28%, or 17 Bcf/d, by 2005.

New supplies to replace North America's natural decline of natural gas production could be developed from a combination of the following sources:

- existing producing basins in the United States, Canada and Mexico;
- frontier basins in Alaska, northern Canada and offshore deepwater;
- areas currently restricted from exploration and development due to public policies, such as areas in the Rocky Mountains and offshore Atlantic, Pacific and Gulf of Mexico coasts; and
- imported LNG.

In addition, demand for natural gas could be met by alternative energy forms, including coal, hydroelectric, oil, wind, solar and nuclear energy. LNG will face competition from each of these energy sources.

We compete with other companies to be among the first to construct LNG receiving terminals in economically desirable locations. According to FERC, there are currently over 40 LNG receiving terminals actively proposed to be constructed in the United States, although we anticipate that only four new terminals will be constructed in the United States by 2010. In addition, one shipboard regasification facility has commenced operations, and companies are pursuing other offshore terminals and shipboard regasification facilities to import LNG into U.S. markets.

BP Statistical Review has reported that, as of December 31, 2004, there was 6,333 Tcf of proved natural gas reserves worldwide, and we believe that LNG has the potential to be a significant new source of lower cost supply to North America. We will compete with other importers of LNG at existing and proposed North American LNG receiving terminals. As of December 31, 2005, there were four onshore LNG receiving terminals operating in North America, which will compete with any terminals that we develop. We believe that all of the capacity at these four existing onshore United States terminals is committed to customers under long-term arrangements. As of December 31, 2005, there were 44 LNG receiving terminals in 12 countries, and we will compete with these and other proposed LNG receiving terminals worldwide to be the most economical delivery point for LNG production for both long-term contracted and spot volumes.

### **Governmental Regulation**

Our LNG operations are subject to extensive regulation under federal, state and local statutes, rules, regulations and other laws. Among other matters, these laws require the acquisition of certain consultations, permits and other authorizations before commencement of construction and operation of our LNG receiving terminals. This regulatory burden increases the cost of constructing and operating the LNG receiving terminals, and failure to comply with such laws could result in substantial penalties.

---

## **Table of Contents**

### ***FERC***

In order to site, construct and operate our proposed LNG receiving terminals, we must receive and maintain authorization from FERC under Section 3 of the Natural Gas Act of 1938, or NGA. The FERC permitting process includes:

- public notice and public meetings;
- data gathering and analysis at FERC's request;
- issuance of a Draft Environmental Impact Statement by FERC;
- public meetings;
- issuance of a Final Environmental Impact Statement by FERC; and
- FERC order authorizing construction.

In addition, orders from FERC authorizing construction of an LNG receiving terminal are typically subject to specified conditions that must be satisfied prior to commencement of construction.

### ***Other Federal Governmental Permits, Approvals and Consultations***

In addition to FERC authorization under Section 3 of the NGA, our construction and operation of LNG receiving terminals are also subject to additional federal permits, approvals and consultations required by certain other federal agencies, including: Advisory Counsel on Historic Preservation, U.S. Army Corps of Engineers, U.S. Department of Commerce, National Marine Fisheries Services, U.S. Department of the Interior, U.S. Fish and Wildlife Service, U.S. Environmental Protection Agency and U.S. Department of Homeland Security.

Our LNG receiving terminals will also be subject to U.S. Department of Transportation siting requirements and regulations of the U.S. Coast Guard relating to facility security. Moreover, our LNG receiving terminals will also be subject to local and state laws, rules and regulations.

### ***Energy Policy Act of 2005***

In 2005, the Energy Policy Act of 2005, or EPAct, was signed into law. The EPAct contains numerous provisions relevant to the natural gas industry and to interstate pipelines. The EPAct includes several provisions which amend the NGA. The primary provisions of interest to our proposed interstate pipelines focus on two areas: infrastructure development, and market manipulation and enforcement. Regarding infrastructure development, the EPAct states that FERC has exclusive authority to approve or deny an application for the siting, construction, expansion or operation of an LNG receiving terminal. The EPAct also provides for market-based rates for new storage facilities placed into service after August 8, 2005, even if the storage provider has market power if FERC determines that market-based rates are in the public interest and necessary to encourage the construction of the storage capacity and customers are adequately protected from the exercise of market power. Regarding market manipulation and enforcement, the EPAct amends the NGA to prohibit market manipulation. The EPAct also amends the NGA and the NGPA to increase civil and criminal penalties. FERC has initiated a rulemaking proceeding regarding market-based storage rates. In addition, FERC issued a Final Rule effective January 26, 2006 regarding market manipulation, which makes it unlawful for any entity, in connection with the purchase or sale of natural gas or transportation service subject to FERC's jurisdiction, to defraud, make an untrue statement or omit a material fact or engage in any practice, act or course of business that operates or would operate as a fraud. This Final Rule works together with FERC's enhanced penalty authority to provide increased oversight of the natural gas marketplace.

### ***Environmental Matters***

Our LNG operations are subject to various federal, state and local laws and regulations relating to the protection of the environment. In some cases, these laws and regulations require us to obtain governmental

---

## Table of Contents

authorizations before we may conduct certain activities or may require us to limit certain activities in order to protect endangered or threatened species or sensitive areas. These environmental laws may impose substantial penalties for noncompliance and substantial liabilities for pollution. As with the industry generally, compliance with these laws increases our overall cost of business. While these laws affect our capital expenditures and earnings, we believe that these regulations do not affect our competitive position in the industry because our competitors are similarly affected by these laws. Environmental regulations have historically been subject to frequent change. Consequently, we are unable to predict the future costs or other future impacts of environmental regulations on our future operations.

The federal Comprehensive Environmental Response, Compensation and Liability Act, or CERCLA, also known as the “Superfund” law, imposes liability, without regard to fault, on certain classes of persons who are considered to be responsible for the spill or release of a hazardous substance into the environment. Potentially liable persons include the owner or operator of the site where the release occurred and persons who disposed or arranged for the disposal of hazardous substances at the site. Under CERCLA, responsible persons may be subject to joint and several liability for:

- the costs of cleaning up the hazardous substances that have been released into the environment;
- damages to natural resources; and
- the costs of certain health studies.

In addition, it is not uncommon for neighboring landowners and other third parties to file claims for personal injury and property damage allegedly caused by the release of hazardous substances. Although CERCLA currently excludes petroleum, natural gas, natural gas liquids and liquefied natural gas from its definition of “hazardous substances,” this exemption may be limited or modified by the United States Congress in the future.

Our operations are subject to the federal Clean Air Act, or CAA, and comparable state and local laws. Amendments to the CAA were adopted in 1990 and contain provisions that may result in the gradual imposition of certain pollution control requirements with respect to air emissions from our operations. The Environmental Protection Agency, or EPA, and states have been developing regulations to implement these requirements. We may be required to incur certain capital expenditures in the next several years for air pollution control equipment in connection with maintaining or obtaining permits and approvals addressing other air emission-related issues. We do not believe, however, that our operations will be materially adversely affected by any such requirements.

Certain persons have expressed concerns that air emissions from our Sabine Pass LNG project located in Cameron Parish, Louisiana, which are allowed under our existing permits, will adversely impact regional air quality in southeastern Texas so as to trigger future federal sanctions for that area under the Clean Air Act. While we have no reason to believe that any formal challenge will be made regarding our existing permits under the Clean Air Act, there can be no assurance that challenges will not be pursued or that, if pursued, they would not result in costs or conditions that could have a material adverse effect on our business and operations.

Our operations are also subject to the federal Clean Water Act, or CWA, and analogous state and local laws. Pursuant to certain requirements of the CWA, the EPA has adopted regulations concerning discharges of storm water runoff. This program requires covered facilities to obtain individual permits, participate in a group permit or seek coverage under an EPA general permit. In addition, our operations, including construction of LNG receiving terminals, in areas deemed to be wetlands, or which otherwise involve discharges of dredged or fill material into navigable waters of the United States, may be subject to Army Corps of Engineers permitting requirements.

The federal Resource Conservation and Recovery Act, or RCRA, and comparable state statutes govern the disposal of “hazardous wastes.” In the event any hazardous wastes are generated in connection with our LNG operations, we may be subject to regulatory requirements affecting the handling, transportation, storage and disposal of such wastes.

---

## **Table of Contents**

Our operations may be restricted by requirements under the Environmental Species Act, or ESA, which seeks to ensure that human activities do not jeopardize endangered or threatened animal, fish and plant species nor destroy or modify their critical habitats.

### **Natural Gas Pipeline Development Business**

We formed Cheniere Pipeline Company, a wholly-owned subsidiary, to develop natural gas pipelines that will provide optimal access to North American natural gas markets for customers of our Sabine Pass, Corpus Christi and Creole Trail LNG receiving terminals. Development efforts to date have focused primarily on advancing our pipeline projects through the regulatory review and authorization process. As these development efforts have progressed, our focus has expanded to also include the construction and operation of our proposed natural gas pipelines. Our pipeline systems will connect with multiple pipelines that provide a means of delivering revaporized natural gas from our LNG receiving terminals to various North American natural gas markets. Our ultimate decisions regarding pipeline connections to our facilities will depend upon future events, including, in particular, customer preferences and general market demand for natural gas from a particular LNG receiving terminal.

### **Our Proposed Pipelines**

#### ***Sabine Pass Pipeline***

We formed Cheniere Sabine Pass Pipeline Company, a wholly-owned subsidiary of Cheniere, to develop, construct, own and operate the natural gas pipeline servicing our Sabine Pass LNG receiving terminal. FERC issued an order in December 2004 authorizing construction, subject to specified conditions that must be satisfied, of our proposed 16-mile, 42-inch diameter natural gas pipeline connection to our Sabine Pass LNG receiving terminal. This interstate pipeline is designed to transport 2.6 Bcf/d of regasified LNG from the site of our Sabine Pass LNG facility, running easterly along a corridor that will allow for interconnection points with existing interstate and intrastate natural gas pipelines in southwest Louisiana, including pipelines operated by Natural Gas Pipeline Company of America, Transcontinental Gas Pipeline Corporation, Tennessee Gas Pipeline Company, Florida Gas Transmission and Bridgeline Holdings, L.P. We believe that these existing pipelines are currently capable of transporting approximately 3.8 Bcf/d.

Preliminary engineering, survey and easement acquisition is in progress. Subject to FERC approval of the implementation plan for construction of our Sabine Pass pipeline, we anticipate beginning construction in early 2007. We anticipate commencing operations of the pipeline in the fourth quarter of 2007.

We estimate that the total cost to construct the Sabine Pass pipeline, including certain work not included in the EPC pipeline contract, such as interconnection with third-party pipelines, will be approximately \$90 million. Our total cost estimate is preliminary and subject to change due to such items as cost overruns, change orders, changes in commodity prices (particularly steel) and escalating labor costs.

#### ***EPC Pipeline Contract***

On February 21, 2006, Cheniere Sabine Pass Pipeline Company entered into an EPC pipeline contract with Willbros Engineers, Inc., or Willbros. Under the EPC pipeline contract, which is effective as of February 1, 2006, Willbros will provide Cheniere Sabine Pass Pipeline Company with services for the management, engineering, material procurement, construction and construction management of the Sabine Pass pipeline. Cheniere Sabine Pass Pipeline Company entered into the EPC pipeline contract sufficiently in advance of commencement of physical construction of the pipeline in order to perform detailed engineering and procure materials.

The work to be performed by Willbros includes all management, engineering, procurement, construction and construction management for the Sabine Pass pipeline, including providing all equipment, materials, supplies, labor, workmanship, apparatus, machinery, tools, structures, inspection, manufacture, fabrication,

---

## Table of Contents

installation, design, delivery, transportation, storage and any incidental work reasonably inferable as required and necessary to complete the Sabine Pass pipeline in accordance with applicable law, applicable codes and standards and all other provisions of the EPC pipeline contract. In addition, Willbros will provide reasonable assistance to Cheniere Sabine Pass Pipeline Company in its efforts to obtain required rights of way, access roads, pipe yards, ware yards and all other land rights or property interests necessary for construction.

The work to be performed by Willbros is based upon and must comply with the preliminary engineering developed by Cheniere Sabine Pass Pipeline Company's other consultants and contractors and the certificate issued by FERC authorizing, among other things, the construction of the Sabine Pass pipeline.

Willbros may not commence work related to ware yard preparation and material receipt earlier than January 1, 2007 and may not commence work related to the construction of the Sabine Pass pipeline earlier than April 1, 2007. Willbros must achieve mechanical completion of the Sabine Pass pipeline no later than September 30, 2007, except as adjusted by change order. At any time upon written notice, either party has the right to request change orders.

Cheniere Sabine Pass Pipeline Company will pay to Willbros a contract price not to exceed \$67.7 million, subject to additions and deductions by any change order as provided in the EPC pipeline contract, excluding Louisiana sales and use taxes applicable to permanent materials and equipment to be incorporated into the Sabine Pass pipeline, which Cheniere Sabine Pass Pipeline Company is obligated to reimburse in accordance with the EPC pipeline contract.

Payments under the EPC pipeline contract will be made in accordance with the payment schedule set forth in the EPC pipeline contract.

Willbros warrants that the work and each component thereof will be:

- new, complete, fit for the purposes specified in the EPC pipeline contract and of suitable grade for the intended function and use;
- in accordance with all of the requirements of the EPC pipeline contract, including in accordance with good engineering and construction practices, applicable law and applicable codes and standards;
- free from encumbrances to title; and
- free from defects in design, material and workmanship and otherwise conform to the standards and requirements contained in the specifications and elsewhere in the EPC pipeline contract.

Except with respect to materials or equipment procured by Willbros from a third-party vendor, if within 12 months after start-up any work is found to be defective, Willbros will be obligated to immediately and on an expedited basis correct any such defective work. With respect to materials or equipment procured by Willbros from a third-party vendor, Willbros' liability during the 12 months after start-up for such materials and equipment will be limited to "passing through" to Cheniere Sabine Pass Pipeline Company the benefits of any warranties Willbros receives from the applicable vendor.

In the event of an uncured default by Willbros, Cheniere Sabine Pass Pipeline Company may terminate for default Willbros' performance of all or part of the work. In the case of termination for default, Cheniere Sabine Pass Pipeline Company may complete the work by whatever method it deems expedient, including:

- taking possession, for the purposes of completing the work, of all Willbros equipment and materials, and/or
- taking assignment of any or all subcontracts or purchase orders for the construction of the Sabine Pass pipeline.

Following such a termination, Willbros will not be entitled to receive any further payment until the work is fully completed and accepted by Cheniere Sabine Pass Pipeline Company, and Willbros will be liable to

---

## **Table of Contents**

Cheniere Sabine Pass Pipeline Company for all costs, damages, losses and expenses (including all attorneys' fees, consultant fees and litigation or arbitration expenses) incurred by Cheniere Sabine Pass Pipeline Company in completing the work, including all liquidated damages to the extent payable pursuant to the EPC pipeline contract.

Cheniere Sabine Pass Pipeline Company also has the right to terminate the EPC pipeline contract. In the event of any such termination for convenience, Willbros would be paid:

- the reasonable value of the work satisfactorily performed prior to termination (the basis of payment being based on the terms of the EPC pipeline contract, less previous payments, if any, paid to Willbros under the EPC pipeline contract), plus
- reasonable direct close-out costs, but in no event will Willbros be entitled to receive any amount for unabsorbed overhead, contingency or anticipatory profit.

Cheniere Sabine Pass Pipeline Company may at any time, whether or not for cause, suspend performance of the work, or any part thereof, by a change order specifying the work to be suspended and the effective date of such suspension. Except when such suspension ordered by Cheniere Sabine Pass Pipeline Company is the result of or due to the fault or negligence of Willbros or any subcontractor or vendor, Willbros will be entitled to the reasonable costs (including actual, but not unabsorbed, overhead, contingency, risk and reasonable profit) of such suspension incurred during the suspension period, including demobilization and remobilization costs and costs incurred for Willbros personnel and for Willbros equipment, at specified standby rates and a time extension to the preparation and material receipt commencement date, the construction commencement date or the scheduled mechanical completion date if and to the extent permitted under the EPC pipeline contract.

If the commencement, prosecution or completion of any work is delayed by a *force majeure* event, then Willbros may be entitled to an extension to the scheduled mechanical completion date. If such delay or prevention occurs for a continuous period of at least 5 days in any 30 day period, Willbros would be entitled to an adjustment of the contract price under the EPC pipeline contract to reimburse it for its standby expenses, up to a limit of \$1.5 million in the aggregate. A *force majeure* event generally occurs if any act or event occurs that:

- renders impossible or impracticable the affected party's performance of its obligations under the EPC pipeline contract;
- is beyond the reasonable control of the affected party and not due to its fault or negligence; and
- could not have been prevented or avoided by the affected party through the exercise of due diligence.

The obligation of either party to pay money under or pursuant to the EPC pipeline contract will not be excused by reason of *force majeure* event.

### ***Corpus Christi Pipeline***

We formed Cheniere Corpus Christi Pipeline Company, a wholly-owned subsidiary of Cheniere, to develop, construct, own and operate the natural gas pipeline servicing our Corpus Christi LNG receiving terminal. FERC issued an order in April 2005 authorizing construction, subject to specified conditions that must be satisfied, of our proposed 24-mile, 48-inch diameter natural gas pipeline. This interstate pipeline is designed to transport 2.6 Bcf/d of regasified LNG from the site of our proposed Corpus Christi LNG receiving terminal, running northwesterly along a corridor that will allow for interconnection points with interstate and intrastate natural gas transmission pipelines in South Texas, including existing pipelines operated by Texas Eastern Transmission Corporation, Gulf South Pipeline Company, L.P., Gulf Terra Intrastate, L.P. (Channel), Kinder Morgan Tejas Pipeline, L.P., Crosstex CCNG Marketing, Ltd., Transcontinental Gas Pipeline Corporation, Tennessee Gas Pipeline Company and Natural Gas Pipeline Company of America. We believe these existing pipelines are currently capable of transporting approximately 4.6 Bcf/d. Construction contracts for the Corpus Christi pipeline have not been negotiated.



---

## **Table of Contents**

### ***Creole Trail Pipelines***

We formed Cheniere Creole Trail Pipeline Company, a wholly-owned subsidiary of Cheniere, to develop, construct, own and operate the natural gas pipelines servicing our Creole Trail LNG receiving terminal. In connection with the FERC application for our Creole Trail LNG receiving terminal, we have sought approval to construct dual 117-mile, 42-inch diameter natural gas pipelines. These interstate pipelines are designed to transport 3.3 Bcf/d of regasified LNG from the site of our proposed Creole Trail LNG receiving terminal, running north/northeasterly along a corridor through six Louisiana parishes and terminating near Rayne, Louisiana. The Creole Trail pipelines are anticipated to be designed with potential interconnections to existing interstate and intrastate natural gas pipelines in southwestern Louisiana operated by ANR Pipeline Company, Bridgeline Holdings, L.P., Sabine Pipeline Company, Targa Louisiana Intrastate L.L.C., Gulf South Pipeline Company, L.P., Transcontinental Gas Pipeline Corporation, Trunkline Gas Pipeline Company, Texas Eastern Transmission Corporation, Tennessee Gas Pipeline, Florida Gas Transmission Company, Columbia Gulf Transmission Company and Cypress Gas Pipeline, L.L.C. We believe that these existing pipelines are currently capable of transporting approximately 12.0 Bcf/d. Construction contracts for the Creole Trail pipeline have not been negotiated.

### ***Other Pipelines***

We continue to evaluate, and may develop, additional pipelines that we believe may be commercially desirable based on customer preferences and general market demand for natural gas from a particular LNG receiving terminal.

### **Funding**

We estimate that approximately \$800 million to \$1 billion of total capital expenditures will be required to construct our three proposed pipelines. We currently expect to fund the costs of our proposed pipelines from our existing cash balances, project financing, proceeds from future debt or equity offerings, or a combination thereof.

### **Customers**

We offered our pipeline capacity to potential customers through a formal request-for-proposal process, and we awarded our marketing affiliate all of the capacity in our proposed Sabine Pass and Corpus Christi pipelines. Cheniere Marketing has entered into binding precedent agreements for transportation services on each of these pipelines at the maximum tariff rate for the transport and sale of revaporized natural gas that it derives from its own imported LNG or LNG that it purchases from other importers for sale into North American markets. See “—LNG and Natural Gas Marketing Business” below. Transportation precedent agreements have not been executed for our Creole Trail pipelines. Cheniere Marketing’s capacity rights and obligations under the transportation precedent agreements are fully assignable, and we anticipate that unaffiliated customers with whom we enter into TUAs for our LNG receiving terminals will also desire to enter into agreements for the transportation of revaporized gas on our proposed pipelines. Furthermore, we expect that other unaffiliated third-party shippers of domestic natural gas may desire transportation services in our pipelines on at least an interruptible basis.

### **Competition**

Our proposed pipeline business would compete with intrastate pipelines in Texas and Louisiana and other interstate pipelines throughout our service territory. The principal elements of competition among pipelines are rates, terms of service, access to supply and flexibility and reliability of service. In addition, FERC’s continuing efforts to increase competition in the natural gas industry are increasing the natural gas transportation options of a pipeline’s traditional customers.

Our pipelines will face competition from other intrastate and/or interstate pipelines that connect with our LNG receiving terminals. In particular, our Sabine Pass pipeline will compete with the proposed Kinder Morgan

---

## **Table of Contents**

Louisiana Pipeline owned by Kinder Morgan Energy Partners, L.P., or Kinder Morgan. Kinder Morgan has announced that it is building a 3.2 Bcf/d take-away pipeline system from our Sabine Pass LNG receiving terminal. The Kinder Morgan Louisiana Pipeline will consist of two segments: a 137-mile, 2 Bcf/d pipeline extending to Evangeline Parish, Louisiana, and interconnecting with 11 interstate pipelines as well as a series of intrastate pipes; and a one-mile, 1.2 Bcf/d pipeline interconnecting with the Natural Gas Pipeline Co. of America system near our Sabine Pass LNG receiving terminal. Total and Chevron USA have both announced agreements with Kinder Morgan securing 100% of the initial capacity on the Kinder Morgan Louisiana Pipeline for 20 years.

### **Governmental Regulation**

#### ***Interstate Natural Gas Pipelines***

Under the NGA, FERC regulates the transportation of natural gas in interstate commerce. Under FERC's regulations, "transportation" service includes natural gas storage service. In general, FERC's authority to regulate pipelines and the services they provide includes:

- rates and charges for natural gas transportation and related services;
- the certification and construction of new facilities;
- the extension and abandonment of services and facilities;
- the maintenance of accounts and records;
- the acquisition and disposition of facilities;
- the initiation and discontinuation of services; and
- various other matters.

Failure to comply with the NGA can result in the imposition of administrative, civil and criminal remedies, including civil and criminal penalties which were recently increased under the EPAct.

The natural gas industry historically has been heavily regulated. FERC regulates the transportation rates and terms and conditions of service of interstate natural gas pipelines. See "—Rates" below. In recent years, FERC has pursued pro-competitive policies in its regulation of interstate natural gas pipelines. However, FERC may not continue this approach.

Our Sabine Pass, Corpus Christi and Creole Trail pipelines will be interstate natural gas pipelines, which will connect our LNG facilities directly to the interstate natural gas pipeline grid. To the extent that we construct and operate interstate natural gas pipelines, we must obtain authorization pursuant to Section 7 of the NGA to construct and operate these pipeline facilities and the rates that we charge will be subject to FERC's regulation under NGA Section 4 as well as to FERC's open access and tariff requirements. FERC's exercise of jurisdiction over interstate gas pipelines is substantially broader than its exercise of jurisdiction over LNG terminals and would continue as long as these pipelines are operated in interstate commerce.

#### ***Pipeline Safety***

Louisiana and Texas administer federal pipeline safety standards under the Natural Gas Pipeline Safety Act of 1968, as amended, or the NGPSA, which requires certain pipelines to comply with safety standards in constructing and operating the pipelines and subjects the pipelines to regular inspections. Failure to comply with the NGPSA may result in the imposition of administrative, civil and criminal remedies.

The Pipeline Safety Improvement Act of 2002, or PSIA, which is administered by the U.S. Department of Transportation Office of Pipeline Safety, or OPS, governs the areas of testing, education, training and communication. The PSIA requires pipeline companies to perform integrity tests on natural gas transmission

---

## Table of Contents

pipelines that exist in high population density areas designated as “high consequence areas.” Pipeline companies are required to perform the integrity tests on a seven year cycle. The risk ratings are based on numerous factors, including the population density in the geographic regions served by a particular pipeline, as well as the age and condition of the pipeline and its protective coating. Testing consists of hydrostatic testing, internal electronic testing, or direct assessment of the piping. In addition to the pipeline integrity tests, pipeline companies must implement a qualification program to make certain that employees are properly trained. In December 2003, the Department of Transportation issued a Final Rule that became effective January 14, 2004, requiring pipeline operators to develop integrity management programs for gas transportation pipelines. The Final Rule requires pipeline operators to perform ongoing assessments of pipeline integrity; identify and characterize applicable threats to pipeline segments that could impact a high consequence area; improve data collection, integration and analysis; repair and remediate the pipeline, as necessary; and implement preventive and mitigation actions. This rule incorporates the requirements of the PSIA.

### *Energy Policy Act of 2005*

The EPAct contains numerous provisions relevant to the natural gas industry and to interstate pipelines. See “—LNG Receiving Terminal Development Business— Governmental Regulation—Energy Policy Act of 2005.”

### *Rates*

Under the NGA, rates charged for the interstate transportation of natural gas must be just and reasonable and non-discriminatory. Amounts collected by the pipeline in excess of just and reasonable rates are subject to refund with interest. Beginning in the mid-1980s, FERC initiated a number of regulatory changes intended to create a more competitive environment in the natural gas marketplace. Among the most important of these changes were:

- Order No. 436 (1985) requiring open-access, nondiscriminatory transportation of natural gas;
- Order No. 497 (1988), which set forth new standards and guidelines imposing certain constraints on the interaction between interstate natural gas pipelines and their marketing affiliates and imposing certain disclosure requirements regarding that interaction; and
- Order No. 636 (1992), which required interstate natural gas pipelines that perform open-access transportation under blanket certificates to “unbundle” or separate their traditional merchant sales services from their transportation and storage services and to provide comparable transportation and storage services with respect to all natural gas supplies whether purchased from the pipeline or from other merchants such as marketers or producers. Order No. 636 also permitted pipeline customers to release all or part of their firm transportation capacity to third parties. Order 636 has been affirmed in all material respects upon judicial review.
- Order No. 637 (2000) which, among other things, required pipelines to implement imbalance management services; restricted the ability of pipelines to impose penalties for imbalances, overruns and non-compliance with operational flow orders; and implemented new pipeline reporting requirements.

On November 25, 2003, FERC issued a series of orders adopting revised Standards of Conduct (Order No. 2004) that apply uniformly to interstate natural gas pipelines. In light of the changing structure of the energy industry, these Standards of Conduct govern relationships between regulated interstate natural gas pipelines and all of their energy affiliates. These new Standards of Conduct were designed to govern relationships between the pipeline and any energy affiliate, rather than governing conduct between the pipeline and its marketing affiliate. The rule is designed to prevent interstate natural gas pipelines from giving an undue preference to any of their energy affiliates and to ensure that transmission is provided on a nondiscriminatory basis. Order No. 2004 requires interstate pipelines to operate independently from their energy affiliates, prohibits interstate pipelines from providing non-public transportation or shipper information to their energy affiliates, and prohibits interstate pipelines from favoring their energy affiliates in providing service. Our interstate natural gas pipelines will be required to comply with these Standards of Conduct.

---

## [Table of Contents](#)

### **Environmental Matters**

Our pipeline business will be subject to the same federal, state and local laws and regulations relating to the protection of the environment that are applicable to our LNG receiving terminals. See “—LNG Receiving Terminal Development Business—Environmental Matters” above.

### **LNG and Natural Gas Marketing Business**

Our LNG and natural gas marketing business is in its early stages of development. We have formed Cheniere Marketing to utilize the portion of our planned LNG receiving terminal regasification capacity that we intend not to allocate to third parties but rather to reserve for use by Cheniere Marketing. Cheniere Marketing anticipates entering into IPAs for approximately 3.0 Bcf/d for LNG purchased from foreign suppliers and then selling revaporized natural gas into North American markets. We intend to purchase LNG from foreign suppliers, arrange the transportation of LNG to our network of LNG receiving terminals, utilize Cheniere Marketing’s reserved revaporization capacity at our terminals to revaporize imported LNG, arrange the transportation of revaporized natural gas through our pipelines and other interconnected pipelines, and sell natural gas to buyers in the North American market. We also expect to enter into domestic natural gas purchase and sale transactions as part of our marketing activities.

To complement our LNG receiving terminal business, we anticipate engaging in the foregoing commercial activities, which may include the use of derivative transactions, to manage or hedge exposure to price, volume, timing, location, quality and credit risk associated with the marketing of LNG and natural gas. We are currently developing risk management policies, procedures and systems to assist us in controlling and managing our proposed marketing activities. We expect that we will need to hire additional employees in connection with the development of our marketing business.

Concurrently with making any commitments to purchase LNG as described above, we expect that Cheniere Marketing would enter into substantially corresponding agreements for the sale of the revaporized gas into the North American market. Although we are actively seeking foreign sources of LNG and domestic buyers of revaporized natural gas for such potential LNG supplies, we currently have no agreements for either, and we may not be able to obtain any such agreements on terms acceptable to us, or at all. We anticipate that credit support may be required by certain counterparties to any of the above-referenced transactions, including derivatives, which may subject us to additional funding requirements.

### **Customers**

#### *Sabine Pass LNG and Corpus Christi LNG*

Cheniere Marketing intends to enter into a TUA with Sabine Pass LNG for 1.5 Bcf/d of regasification capacity at our Sabine Pass LNG receiving terminal, which capacity is expected to be reduced to 600 MMcf/d in the event that both the Total TUA and the Chevron USA TUA commence prior to the completion of Phase 2 of our Sabine Pass LNG facility. In addition, Cheniere Marketing intends to enter into a TUA with Corpus Christi LNG for 1.0 Bcf/d of regasification capacity at our Corpus Christi LNG receiving terminal.

### **Competition**

Our LNG purchase efforts will compete with the following for supplies of LNG:

- large, multinational and national companies with longer operating histories, more development experience, greater name recognition, larger staffs and substantially greater financial, technical and marketing resources; and
- oil and gas producers who sell or control LNG derived from their international oil and gas properties.

In addition, there will be competition for suitable tankers available to transport LNG to North American markets from foreign sources, which will impact our access to LNG supplies and the cost of LNG delivered to the U.S. Gulf Coast.

---

## Table of Contents

Our natural gas marketing business will compete with the following for the sale of natural gas:

- major integrated marketers who have large amounts of capital to support their marketing operations and offer a full-range of services and market numerous products other than natural gas;
- producer marketers who sell their own natural gas production or the production of their affiliated natural gas production company;
- small geographically focused marketers who focus on marketing gas for the geographic area in which their affiliated distributor operates;
- aggregators who gather small volumes from various sources, combine them and sell the larger volumes for more favorable prices and terms than would be possible selling the smaller volumes separately; and
- brokers who act as facilitators, bringing buyers and sellers of natural gas together.

### **J & S Cheniere**

We hold a minority interest in J & S Cheniere S.A., or J & S Cheniere. The majority interest in J & S Cheniere is held by J & S Energy Holding B.V., or J & S Holding, a Netherlands corporation affiliated with J & S Trading Company, Ltd., an international petroleum trading and marketing company. Pursuant to a shareholders agreement, we identify and assist with LNG-related business opportunities that we determine are appropriate for J & S Cheniere. We are not required to offer any particular business opportunities or funding to J & S Cheniere. All financing of these business opportunities will be provided by J & S Holding should it determine that a business opportunity is appropriate for J & S Cheniere. However, J & S Holding is not required to fund any particular business opportunity. The shareholders agreement gives us the right to purchase additional shares up to a maximum of 50% of the outstanding shares of J & S Cheniere. The shareholders agreement also provides J & S Holding the right to acquire all of our J & S Cheniere shares in the event that we experience a change in control (defined in the shareholders agreement to include a change in a majority of our board, the acquisition of more than 40% of our outstanding common stock other than as approved by our board of directors and a merger or consolidation that results in 50% or less of the surviving entity's voting securities being owned by the holders of our voting securities immediately prior to such transaction).

As its initial LNG business opportunity, in August 2003, J & S Cheniere chartered its first LNG tanker, the 130,000 cm-capacity Tenaga Empat. The vessel was operated under a transportation agreement and on a spot charter basis until August 2005.

In August 2004, J & S Cheniere executed a time charter for its second LNG tanker for up to 10 years with Kawasaki Kisen Kaisha, Ltd., or K-Line, to charter a new build, 145,000 cm-capacity LNG tanker being constructed by Kawasaki Shipbuilding Corporation. The tanker is expected to be delivered in the fourth quarter of 2007.

In August 2004, J & S Cheniere also executed a time charter agreement for up to 10 years for its third LNG tanker with a joint venture company established by K-Line, Shoeni Kisen Kaisha, Ltd. and others. The new build, 154,200 cm-capacity LNG tanker is being constructed by Imabari Shipbuilding Co., Ltd. and is expected to be delivered in the fourth quarter of 2007.

J & S Cheniere entered into an agreement with us in December 2003 under which J & S Cheniere has an option to enter into a TUA reserving up to 200 MMcf/d of capacity at each of our Sabine Pass LNG and Corpus Christi LNG facilities. Following execution of the option agreement, an option fee of \$1 million was paid to us in January 2004 by J & S Cheniere. J & S Cheniere may exercise the option as to each facility by entering into a TUA no later than 60 days after receipt of written notification by us that such facility has been approved by FERC and all other approvals and permits have been received which are necessary to begin construction of the facility. The option agreement provides that any such TUA will provide for: (i) a fee per MMBtu delivered equal

---

## **Table of Contents**

to 8% of the then current price of natural gas at Henry Hub (instead of a capacity reservation fee payable whether or not it uses the terminal); (ii) an initial five-year term, with up to three additional five-year renewal periods upon payment of a \$1 million fee for each renewal; and (iii) a minimum of two LNG vessel deliveries per month at the facility. The terms of the TUA contemplated by the J & S Cheniere option agreement have not been negotiated or finalized. We anticipate that definitive arrangements with J & S Cheniere may involve different terms and transaction structures than were contemplated when the option agreement was entered into in December 2003.

We have recently commenced discussions to renegotiate our existing arrangements with, and to increase our ownership interest to as much as 49% in, J & S Cheniere. The related investment is expected to be approximately \$25 million.

### **Governmental Regulation**

The prices at which we will sell natural gas are not regulated, insofar as the interstate market is concerned and, for the most part, are not subject to state regulation. Our sales of natural gas will be affected by the availability, terms and cost of pipeline transportation. As noted above, under “—Natural Gas Pipeline Development Business— Governmental Regulation,” the price and terms of access to pipeline transportation are subject to extensive federal and state regulation. FERC is continually proposing and implementing new rules and regulations affecting interstate natural gas transmission. These initiatives may affect the intrastate transportation of natural gas under certain circumstances. The stated purpose of many of these regulatory changes is to promote competition among the various sectors of the natural gas industry, and these initiatives generally reflect more light-handed regulation. We cannot predict the ultimate impact of these regulatory changes to our proposed natural gas marketing operations. We do not believe that we will be affected by any such FERC action materially differently than other natural gas marketers with whom we anticipate competing.

### **Oil and Gas Exploration and Development Business**

Although our focus is primarily on development of LNG-related businesses, we continue to be involved to a limited extent in oil and gas exploration, development and exploitation, and in exploitation of our existing 3D seismic database through prospect generation. We have historically focused on evaluating and generating drilling prospects using a regional and integrated approach with a large seismic database as a platform. We expect that our oil and gas exploration activities will continue in the Gulf of Mexico, through active interpretation of our seismic data and generation of prospects, through participation in the drilling of wells, and through farm-out arrangements and back-in interests (a reversionary interest in oil and gas leases reserved by us) whereby the capital costs of such activities are borne primarily by industry partners. Cheniere will, from time to time, invest in drilling a share of these prospects. Our current oil and gas exploration and development activities are focused on two areas:

- the Cameron Project, which covers an area of approximately 230 square miles extending roughly three to five miles on either side of the westernmost 28 miles of Louisiana coastline; and
- the Offshore Texas Project Area, which covers approximately 6,800 square miles in the shallow waters offshore Texas and the West Cameron Area of offshore Louisiana.

Our officers and technical staff have extensive experience both onshore and offshore in the Gulf Coast and believe that we are well-positioned to evaluate, explore and develop properties in these areas. From time to time, we may pursue opportunities in other geographic locations as well.

### **Cameron Project Seismic Exploration Program**

We were formed in 1996 to fund the acquisition of a proprietary seismic database along the transition zone (the area approximately three to five miles on either side of the Gulf of Mexico shore line) in Cameron Parish,

---

## **Table of Contents**

Louisiana. Under the terms of an exploration agreement with an industry partner, we paid for certain seismic costs in the amount of approximately \$16.5 million and acquired a 50% ownership interest in the seismic data covering the Cameron project, among other interests that have subsequently expired or terminated. After the termination of the exploration agreement, we purchased our partner's 50% interest in the seismic data for \$500,000 and sold all of the seismic data to a seismic marketing company for \$3.3 million. We now retain a license to all of the seismic data for use in our exploration program. We are also entitled to receive at no additional cost any subsequent reprocessing of the data, which may be performed by the seismic marketing company.

In 1999, we licensed 8,800 square miles of seismic data from Fairfield Industries covering a portion of the Offshore Louisiana Area, and made a commitment to fund the reprocessing of the entire 8,800-square-mile seismic database. In 2000, we entered into an agreement with Warburg, Pincus Equity Partners, L.P., a global private equity fund based in New York, to fund exploration and development in the Offshore Louisiana Area through a then newly formed private corporation, Gryphon Exploration Company, or Gryphon. In September 2005, Gryphon was sold, which resulted in net proceeds to us of \$20.2 million.

### **Seismic Exploration Program in Offshore Texas Project Area**

In 2000, we acquired two licenses to an aggregate of approximately 1,900 square miles of seismic data from Seitel Data Ltd., a division of Seitel Inc. In October 2000, we exercised our option to expand the agreement with Seitel Data Ltd. to cover an additional 1,900 square miles of seismic data. Together, the licenses acquired from Seitel represent coverage of over 433 Outer Continental Shelf blocks in the shallow waters offshore Texas and Louisiana in the Gulf of Mexico. In 2001, we sold to Gryphon for \$3.5 million one of our two licenses to the Seitel 3D seismic data. We retain one license to the Seitel 3D seismic data.

In 2000, we also negotiated a Master Data Users Agreement with a Houston-based firm, Jebco Seismic L.P., to acquire 3,000 square miles (333 blocks) of seismic data in both state and federal waters offshore Texas, bringing our total data set in the shallow waters offshore Texas and Louisiana to approximately 6,800 square miles of seismic coverage. As of December 31, 2003, we had received reprocessed data for the 3,000 square miles of seismic data in the Jebco data set and the 3,800 square miles of seismic data in the Seitel data set, representing all of the reprocessing to be done in the Offshore Texas Project Area. In 2001, we sold to Gryphon for \$3.5 million one of our two licenses to the Jebco 3D seismic data covering an additional 3,000 square miles. We retain one license to the Jebco 3D seismic data.

Our exploration team generated and captured 24 prospects during 2003, 2004 and 2005 and sold interests in 23 of the prospects to industry partners, retaining various overriding royalty interests and working interests ranging from an overriding royalty interest (a share of the hydrocarbons produced from an oil and gas property, free of the expense of production) of 3.358% up to 5.0% to a carried working interest (an agreement whereby we retain an interest in a well but bear none or only a portion of the cost of drilling the initial well) of approximately up to 24% and a cost-bearing working interest of up to 25%. Fourteen of the prospects sold during 2003, 2004 and 2005 have been drilled by our industry partners, and we expect that several of the remaining prospects sold during that period will be drilled by our industry partners during 2006. However, we do not serve as operator of any of these prospects, and our partners in the prospects are not contractually obligated to drill them.

### **Drilling Activities**

During 2003 and 2004, we did not participate directly in the drilling of any wells; in 2005, we participated directly in the drilling of two wells. Our industry partners drilled nine wells, two wells and three wells in 2003, 2004 and 2005, respectively, on prospects that we generated. During 2003, seven of the nine wells were productive; during 2004, both wells were productive; and during 2005, one well was productive. At December 31, 2005, we had a 20% working interest in one well and overriding royalty interests (ranging from 0.63% to 5.0%) in nine other productive wells.

## Table of Contents

### Production and Sales

The following table presents certain information with respect to our oil and natural gas production, average sales prices received and average production costs during 2003, 2004 and 2005. In April 2002, we sold our interests in the Redfish and Stingray wells on West Cameron Block 49, representing all of our directly-owned producing properties at the time.

	Year Ended December 31,		
	2005	2004	2003
<b>Production:</b>			
Oil (Bbl)	2,167	1,362	17
Gas (Mcf)	396,284	328,677	123,392
Gas equivalents (Mcf)	409,286	336,849	123,494
<b>Average sales prices:</b>			
Oil (per Bbl)	\$ 48.64	\$ 36.69	\$ 20.66
Gas (per Mcf)	\$ 7.32	\$ 5.93	\$ 5.33
<b>Selected data per Mcfe:</b>			
Average sales price	\$ 7.34	\$ 5.93	\$ 5.32
Production costs(1)	\$ 0.58	\$ 0.35	\$ —
Oil and gas depreciation, depletion and amortization excluding impairments	\$ 5.90	\$ 2.48	\$ 0.98

- (1) No production costs were recorded in 2003, as we owned non-cost bearing overriding royalty interests in wells located in offshore federal waters not subject to state production taxes.

### Acreage and Wells

The following table sets forth certain information with respect to our developed and undeveloped leased acreage as of December 31, 2005.

	Developed Acres		Undeveloped Acres(1)	
	Gross	Net	Gross	Net
Offshore Louisiana	—	—	10,000	513
Offshore Texas	640	128	40,426	12,148
<b>Total</b>	<b>640</b>	<b>128</b>	<b>50,426</b>	<b>12,661</b>

- (1) We have 421 net lease acres expiring in 2006.

At December 31, 2005, we had working interests in one gross (0.2 net) producing gas well; we had overriding royalty interests in nine producing gas wells.

### Drilling Activities

All of our drilling activities are conducted through arrangements with independent contractors. We own no drilling equipment. At December 31, 2005, we had a net working interest of 20% in one exploratory gas well.

### Oil and Gas Reserves

All of the information herein regarding estimates of our proved reserves, related future net revenues and PV-10 as of December 31, 2005 is taken from the report generated by Sharp Petroleum Engineering, Inc., our independent petroleum engineer, in accordance with the rules and regulations of the SEC. The independent



## Table of Contents

engineer's estimates were based upon a review of production histories and other geologic, economic, ownership and engineering data that we provided.

	December 31, 2005			
	Proved Reserves			
	Oil (Bbl)	Gas (Mcf)	Mcf	PV-10(1)
Offshore Texas	147	145,179	146,061	\$ 737,642
Offshore Louisiana	1,166	245,508	252,504	\$ 2,007,249
Proved Reserves	1,313	390,687	398,565	\$ 2,744,891
Proved Developed Reserves	1,313	390,687	398,565	\$ 2,744,891

- (1) The PV-10 amount (present value of estimated pre-tax future net revenues discounted at 10%) is calculated using year-end prices of \$53.72 per barrel of oil and \$8.90 per Mcf of gas.

There are numerous uncertainties inherent in estimating quantities of proved reserves and in projecting future rates of production and future amounts and timing of development expenditures, including many factors beyond our control. Reserve engineering is a subjective process of estimating underground accumulations of crude oil and natural gas that cannot be measured in an exact manner, and the accuracy of any reserve estimate is a function of the quality of available data and of engineering and geological interpretation and judgment. Estimates of proved undeveloped reserves are inherently less certain than estimates of proved developed reserves. The quantities of oil and gas that are ultimately recovered, production and operating costs, the amount and timing of future development expenditures, geologic success and future oil and gas sales prices may all differ from those assumed in these estimates. In addition, our reserves may be subject to downward or upward revision based upon production history, purchases or sales of properties, results of future development, prevailing oil and gas prices and other factors. Therefore, the present value shown above should not be construed as the current market value of the estimated oil and gas reserves attributable to our properties.

In accordance with SEC guidelines, the estimates of future net revenues from our proved reserves and the present value thereof are made using oil and gas sales prices in effect as of the dates of such estimates and are held constant throughout the life of the properties except where such guidelines permit alternate treatment, including, in the case of gas contracts, the use of fixed and determinable contractual price escalations. We may receive amounts different than the estimates for a number of reasons, including changes in prices. See Supplemental Information to Consolidated Financial Statements. Estimates of our proved oil and gas reserves were not filed with or included in reports to any other federal authority or agency other than the SEC during the fiscal year ended December 31, 2005.

### Business Strategy

Our objective in the Exploration and Development business is to expand the net value of our assets by building an oil and gas reserve base in a cost-efficient manner, through exploitation of our seismic database to facilitate identifying drilling prospects.

#### Seismic Data

We have acquired the following two significant seismic database assets:

- a license to a 228-square-mile seismic program covering the transition zone in Cameron Parish, and
- a license to a 6,800-square-mile seismic database comprising several seismic surveys in the shallow waters offshore Texas and Louisiana.

The offshore Texas database has been available previously to the industry and was processed using a technique called dip move out, or DMO. We acquired the DMO data and underwrote the reprocessing of the data utilizing

---

## **Table of Contents**

another technology known as prestack time migration, or PSTM. Both DMO and PSTM are processing techniques which improve seismic data quality to more accurately image subsurface features and delineate hydrocarbon accumulations. Of the two techniques, PSTM is more advanced and technically accurate. The regional PSTM data is the technology tool which management believes gives us a competitive advantage.

### *Analysis and Methodology*

We have developed a prospect generation infrastructure capable of detailed analyses of large volumes of seismic, geological and engineering data. We employ a rigorous methodology which includes:

- the detailed analyses of existing fields to identify geological and geophysical attributes for use as analogs;
- regional trend mapping to extend prolific plays into under-explored areas;
- the use of workstation interpretation techniques to rapidly identify prospects with attributes similar to those identified in the analog fields;
- the integration of seismic interpretation, well control, structure, stratigraphy, timing, sourcing factors, and production data to quantify prospect potential; and
- the integration of the above sciences with experience and conservative economic evaluation to focus the exploration program on highly commercial projects.

By conducting a thorough analysis of the data and strict adherence to the methodology, we believe that we can reduce the risk of dry holes and achieve significant growth, while maintaining a competitive cost of exploration and development.

### **Experience**

We have built a technical and management team that is experienced in the Gulf of Mexico and in various technical specialties required for our exploration program. The technical staff averages over 30 years of experience exploring for oil and gas in the Gulf Coast. We believe that this experienced team allows us to be very productive in the generation and acquisition of prospects.

### **Competition and Markets**

The availability of a ready market for and the price of any hydrocarbons that we produce will depend on many factors beyond our control, including the extent of domestic production and imports of foreign oil, the marketing of competitive fuels, the proximity and capacity of natural gas pipelines, the availability of transportation and other market facilities, the demand for hydrocarbons, the political conditions in international oil-producing regions, the effect of federal and state regulation of allowable rates of production, taxation, the conduct of drilling operations and federal regulation of natural gas. In the past, as a result of excess deliverability of natural gas, many pipeline companies curtailed the amount of natural gas taken from producing wells, shut in some producing wells, significantly reduced gas taken under existing contracts, refused to make payments under applicable take-or-pay provisions and have not contracted for gas available from some newly completed wells.

In addition, the restructuring of the natural gas pipeline industry has eliminated the gas purchasing activity of traditional interstate gas transmission pipeline buyers. Producers of natural gas, therefore, have been required to develop new markets among gas marketing companies, end-users of natural gas and local distribution companies. All of these factors, together with economic factors in the marketing area, generally may affect the supply and/or demand for oil and gas and thus the prices available for sales of oil and gas.

Competition in the industry is intense, particularly with respect to the acquisition of producing properties and proved undeveloped acreage. We compete with the major oil companies and other independent producers of

---

## **Table of Contents**

varying sizes, all of which are engaged in the exploration, development and acquisition of producing and non-producing properties.

### **Governmental Regulation**

Our oil and gas exploration, development and related operations are subject to extensive federal, state and local statutes, rules, regulations and other laws. Failure to comply with such laws can result in substantial penalties. The regulatory burden on the oil and gas industry increases our cost of doing business and affects our profitability.

#### ***MMS Regulations***

We conduct certain activities on federal oil and gas leases which the Minerals Management Service, or MMS, administers. The MMS grants leases through competitive bidding. These leases contain relatively standardized terms and require compliance with detailed MMS regulations and orders pursuant to The Outer Continental Shelf Lands Act, or OCSLA. For example, for offshore operations, we must comply with the following MMS requirements:

- obtain MMS approval of exploration plans prior to the commencement of exploration operations;
- obtain MMS approval of development and production plans prior to the commencement of such operations;
- obtain an MMS permit prior to the commencement of drilling (in addition to permits which may be required from other agencies, such as the Coast Guard, the Army Corps of Engineers and the Environmental Protection Agency);
- comply with stringent MMS engineering and construction specifications applicable to offshore production facilities located on the Outer Continental Shelf, or OCS;
- comply with MMS prohibitions or restrictions on the flaring or venting of natural gas, liquid hydrocarbons and oil; and
- comply with MMS regulations governing the plugging and abandonment of wells located offshore and the removal of all production facilities.

#### ***Bonding and Financial Responsibility Requirements***

In connection with our ownership or operation of oil and gas leases, we are required by governmental agencies, including the MMS, to obtain bonding or otherwise demonstrate financial responsibility at varying levels. These bonds may cover such obligations as plugging and abandonment of wells, removal and closure of related exploration and production facilities, and pollution liabilities. The costs of such bonding and financial responsibility requirements can be substantial, and we may not be able to obtain such bonds and/or otherwise demonstrate financial responsibility in all cases.

#### ***Regulation of Production***

Our oil and gas production operations are subject to state conservation laws and regulations, including:

- laws relating to the unitization or pooling of oil and gas properties;
- laws establishing the maximum rates of production from wells;
- laws regulating the spacing of wells;
- laws regulating the plugging and abandonment of wells; and
- laws which otherwise regulate the operation of, and production from, both oil and gas wells.

---

## **Table of Contents**

Such laws may restrict the rate at which the wells in which we have an interest may produce oil or gas, with the result that the amount or timing of our revenues could be adversely affected.

### **Environmental Matters**

Our oil and gas exploration, development and related operations are subject to the same federal, state and local laws and regulations relating to the protection of the environment that are applicable to our LNG operations. See “—LNG Receiving Terminal Development Business—Governmental Regulation—Environmental Matters” above. In addition, our oil and gas exploration, development and related operations are subject to the following regulations.

The disposal of wastes containing Naturally Occurring Radioactive Material, which are commonly generated during oil and gas production, is regulated under state law. Typically, wastes containing naturally occurring radioactive material can be managed on site or disposed of at facilities licensed to receive such waste at costs that are not expected to be material.

The federal Oil Pollution Act of 1990, or OPA, requires owners and operators of facilities that could be the source of an oil spill into waters of the United States (a term defined to include rivers, creeks, wetlands and coastal waters) to adopt and implement plans and procedures to prevent any such oil spill. OPA also requires affected facility owners and operators to demonstrate that they have at least \$35 million in financial resources to pay the costs of cleaning up an oil spill and to compensate any parties damaged by an oil spill. Such financial assurances may be increased to as much as \$150 million if a formal assessment indicates such an increase is warranted.

### **Financial Information About Segments**

During the last three fiscal years, all of our revenues have resulted from our oil and gas exploration and development activities. For information about our segments’ revenues, profits and losses and total assets, see Note 23 to our Consolidated Financial Statements.

### **Subsidiaries**

Our assets are generally held by or under our wholly-owned operating subsidiaries. We conduct most of our operations through these subsidiaries, including our operations relating to the development of our LNG receiving terminal business, the development of our pipeline business and our planned marketing business.

### **Employees**

We had 130 full-time employees as of February 28, 2006.

**ITEM 1A. RISK FACTORS**

The following are some of the important factors that could affect our financial performance or could cause actual results to differ materially from estimates contained in our forward-looking statements. We may encounter risks in addition to those described below. Additional risks and uncertainties not currently known to us, or that we currently deem to be immaterial, may also impair or adversely affect our business, results of operation, financial condition and prospects.

**Risks Relating to Our Financial Matters**

***We have not been profitable historically, and we are currently experiencing negative operating cash flow. Our ability to achieve profitability and generate positive operating cash flow in the future is subject to significant uncertainty.***

From our inception, we have generally incurred operating losses, and we will likely continue to incur operating losses and experience negative operating cash flow for at least the next two years. We have not yet started the construction of two of our three planned LNG receiving terminals or our pipelines. We do not anticipate that our LNG receiving operations or our three pipelines will generate positive operating cash flow until at least one of our planned LNG receiving terminals is built, which we expect will not be until 2008 at the earliest. Although we may commence operations at our LNG receiving terminals, revenues under any particular TUA may not commence for up to one year or more after operations at the related facility commence. We will continue to incur significant capital and operating expenditures while we develop our planned LNG receiving terminals and pipelines. We do not anticipate that our current oil and gas exploration activities, which are limited in scope, or advance sales of regasification capacity at our planned LNG receiving terminals will generate sufficient funds to cover these expenditures. As a result, we expect to continue to have operating losses and negative operating cash flow on a quarterly and an annual basis for at least the next two years.

Any delays beyond the expected development periods for our planned LNG receiving terminals or pipelines would prolong, and could increase the level of, our operating losses and negative operating cash flow. Our future liquidity may also be affected by (i) the timing of construction financing availability in relation to the incurrence of construction costs and other outflows and (ii) the anticipated timing of receipt of cash flow under TUAs and other sales of capacity in relation to the incurrence of projected project operating expenses. However, many factors (including factors beyond our control) could result in a disparity between liquidity sources and cash needs, including factors such as construction delays and breaches of agreements. Our ability to generate positive operating cash flow and achieve profitability in the future is dependent on our ability to successfully complete our LNG development projects and market the capacity of our facilities, and our ability to do so is subject to a number of risks, including those discussed below.

***Our ability to develop our planned LNG receiving terminals and pipelines is contingent on our ability to obtain funding. If we are unable to do so, we may be unable to implement or complete our business plan and our business may ultimately be unsuccessful.***

As of December 31, 2005, we had \$693 million in cash and cash equivalents, exclusive of \$177 million in restricted cash. We currently estimate that the cost of completing our three LNG receiving terminals will be approximately \$3.0 billion, before financing costs, and the cost of constructing our three proposed pipelines will be approximately \$800 million to \$1 billion. Our cost estimate is subject to change due to such items as cost overruns, change orders under existing or future EPC agreements, changes in commodity prices (particularly steel), escalating labor costs and additional funds that may need to be expanded to maintain construction schedules. In addition, the development of our marketing business will require the expenditure of funds before any revenues are received. To fund these development projects, we will have to draw on our Sabine Pass Credit Facility and pursue a variety of additional sources of funding, including most, if not all, of the following:

- debt and/or equity financing at the project level;
- debt and/or equity financing by Cheniere; and
- asset sales, to the extent permitted, and joint venture arrangements by Cheniere and/or our subsidiaries.

---

## Table of Contents

Our ability to obtain these types of financing will depend, in part, on factors beyond our control, such as the status of various capital and industry markets at the time financing is sought and such markets' view of our industry and prospects at such time. Accordingly, we may not be able to obtain financing on terms that are acceptable to us, if at all, even if our development projects are otherwise proceeding on schedule. In addition, our ability to obtain some types of financing may be dependent upon our ability to obtain other types of financing. For example, project-level debt financing is typically contingent upon a significant equity capital contribution from the project sponsor. As a result, even if we are able to identify potential project-level lenders, we may still have to obtain another form of external financing for us to fund an equity capital contribution to the project subsidiary. Any project-level debt financing will also typically be conditioned upon our prior receipt of commitments for a portion of projected regasification capacity under long-term TUAs, and our ability to fund the projects will likely be subject to the achievement of additional milestones in our project financing. A failure to obtain financing at any point in the development process could cause us to delay or fail to complete our business plan, which could cause our business to be unsuccessful.

*Even if we are able to obtain financing, the terms required may adversely affect our business.*

In order to obtain many types of financing, we may have to accept terms that are disadvantageous to us or that may have an adverse impact on our current or future business, operations or financial condition. For example:

- borrowings or debt issuances may subject us to certain restrictive covenants, including covenants restricting our ability to raise additional capital or cross-defaults to our other indebtedness;
- borrowings or debt issuances at the project level may subject the project entity to certain restrictive covenants, including covenants restricting its ability to make distributions to us or limiting our ability to sell our interests in such entity;
- additional sales of interests in our LNG projects would reduce our interest in future revenues once the LNG receiving terminals commence operations;
- the prepayment of terminal use fees by, or a business development loan from, prospective customers would reduce future revenues once the LNG receiving terminals commence operations;
- offerings of our equity securities would cause dilution of our common stock;
- sales of oil and gas exploration prospects would reduce potential future revenues from our exploration and production activities;
- our ability to borrow funds under some project financing arrangements will likely be subject to our satisfying the conditions and covenants in the financing and the construction schedule agreed to at the time we enter into such arrangement. If circumstances change, we may need to seek waivers of conditions or covenants under our financing arrangements to prevent defaults thereunder and acceleration thereof, which we might not be able to obtain on a timely basis, or at all; and
- we may be required to make equity contributions before we can borrow under certain financing arrangements, such as the Sabine Pass Credit Facility.

*The actual construction costs of our proposed LNG receiving terminals and pipelines may be significantly higher than our current estimates, which are before financing costs.*

We do not have any prior experience in constructing LNG receiving terminals or pipelines, and no LNG receiving terminal has been constructed in the United States in over 25 years. As construction progresses, we may decide or be forced to submit change orders to our EPC contractors that could result in longer construction periods and higher construction costs. Similarly, we may encounter significant cost overruns during some phases of the construction process. In addition, under any agreement with an EPC contractor, we expect to retain the commodity price risk for nickel and various types of steel used in the construction process. As a result, any significant change orders, cost overruns or increases in the commodity price of nickel or steel could have a material adverse effect on our business, results of operations, financial condition and prospects.

**Risks Relating to Our LNG Receiving Terminal Development Business**

*The construction of our planned LNG receiving terminals is subject to a number of development risks, which could cause cost overruns and delays or prevent completion of one or more of our LNG development projects.*

Key factors that may affect the timing of, and our ability to complete, our LNG development projects include, but are not limited to:

- the issuance and/or continued availability of necessary permits, licenses and approvals from FERC, other governmental agencies and third parties as are required to construct and operate the facilities;
- the availability of sufficient debt financing and equity financing, both on the part of Cheniere and at the project level;
- our ability to obtain satisfactory long-term TUAs with “anchor tenant” customers for a portion of the capacity at each proposed LNG receiving terminal and for these customers to perform under those TUAs during the terms thereof and to maintain their creditworthiness;
- our ability to enter into a satisfactory agreement with an EPC contractor for each facility and to maintain good relationships with these contractors, and the ability of those EPC contractors to perform their obligations under EPC agreements and to maintain their creditworthiness;
- site development difficulties, including change orders, cost overruns, construction delays and changes in commodity prices (particularly steel);
- unanticipated changes in domestic and international market demand for natural gas or the supply of LNG, which will depend, in part, on supplies of, and prices for, alternative energy sources;
- competition with other domestic and international LNG receiving terminals;
- commercial arrangements for pipelines and related equipment to transport natural gas from each LNG receiving terminal;
- local and general economic conditions;
- catastrophes, such as explosions, fires and product spills;
- resistance in the local community to the development of LNG receiving terminals;
- labor disputes; and
- weather conditions, such as hurricanes.

Delays in the construction of an LNG receiving terminal beyond the estimated development periods, as well as cost overruns, could increase the cost of completion beyond the amounts currently estimated in our capital budget, which could require us to obtain additional sources of financing to fund our operations until the LNG receiving terminal is developed (which could cause further delays). Any delay in completion of the LNG receiving terminals may also cause a delay in the receipt of revenues projected from operation of the facilities or cause a loss of our TUA customers in the event of significant delays. Delays could also erode our competitive advantage of being one of the first companies to develop new LNG receiving terminals. As a result, any significant construction delay, whatever the cause, could have a material adverse effect on our business, results of operations, financial condition and prospects.

*Failure to obtain and maintain approvals and permits from governmental and regulatory agencies with respect to the development of our LNG receiving terminal business would have a detrimental effect on us and our LNG projects.*

The design, construction and operation of LNG receiving terminals are all highly regulated activities. FERC approval under Section 3 of the NGA, as well as several other material governmental and regulatory approvals and permits, is required in order to construct and operate our proposed LNG receiving terminals. Although we

---

## **Table of Contents**

have obtained NGA Section 3 authorization to construct and operate our Sabine Pass and Corpus Christi LNG receiving terminals, we have not yet received an NGA Section 3 FERC order authorizing construction of our Creole Trail project. We also have not obtained several other material governmental and regulatory approvals and permits required in order to construct and operate our proposed LNG receiving terminals. We have no control over the outcome of the review and approval process. We do not know whether or when any such approvals or permits can be obtained, or whether or not any existing or potential interventions or other actions by third parties will interfere with our ability to obtain and maintain such permits or approvals. If we are unable to obtain and maintain the necessary approvals and permits, we may not be able to recover our investment in the projects. Failure to obtain and maintain any of these approvals and permits could have a material adverse effect on our business, results of operations, financial condition and prospects.

***We face competition in the LNG receiving terminal development business from competitors with far greater resources and the potential for overcapacity in the LNG receiving terminal marketplace.***

Many companies are considering the development of infrastructure in the domestic LNG market, including, without limitation, major oil and gas companies such as ExxonMobil, ConocoPhillips, Royal Dutch/Shell and Chevron. Other energy companies such as Semptra, Tractebel, McMoRan Exploration, Occidental Petroleum, AES, Excelerate Energy and other public and private companies have also proposed developing LNG receiving facilities, both onshore and offshore. Almost all of our competitors have longer operating histories, more development experience, greater name recognition, larger staffs and substantially greater financial, technical and marketing resources than we do. The superior resources that these competitors have available to deploy could allow them to surpass us in terms of the status of their LNG receiving terminal development projects. Among other things, these competitors may not have to rely on external financing.

Industry analysts have predicted that if all of the proposed LNG receiving terminals in North America that have been announced by developers were actually built, there would likely be substantial excess capacity for such terminals in the future. Accordingly, there is a substantial risk that slower-paced LNG receiving terminal development projects may never be completed. Any perception in the LNG receiving terminal marketplace that we may be unable to complete our proposed LNG receiving terminals, because competing projects are further along in their development or otherwise, could have a material adverse effect on our business, results of operations, financial condition and prospects.

In addition, our proposed LNG receiving terminals will likely continue to face competition when and if they are completed, including competition from North American sources of natural gas and onshore, offshore and shipboard LNG regasification facilities. Our proposed Sabine Pass, Corpus Christi and Creole Trail LNG receiving terminals will also compete with the Freeport LNG receiving terminal in which we own a 30% interest. If the number of LNG receiving terminals built outstrips demand for natural gas from those terminals, the excess capacity will likely lead to a decrease in the prices that we will be able to obtain for uncommitted amounts of our regasification services. Because of the substantial likelihood that we will have significant debt service obligations, any such price decreases would impact us more severely than our competitors with greater financial resources. Accordingly, potential overcapacity in the LNG receiving terminal marketplace, or a significant decline in natural gas prices, could have a material adverse effect on our business, results of operations, financial condition and prospects.

***Cyclical changes in the demand for LNG regasification capacity may result in reduced operating revenues and may cause operating losses in the future.***

The economics of LNG terminal and marketing operations could be subject to cyclical swings, reflecting alternating periods of under-supply and over-supply of LNG importation capacity and available natural gas, principally due to the combined impact of several factors, including:

- significant additions in regasification capacity, whether through LNG receiving terminal construction or expansion, take several years to become operational and are therefore necessarily based upon estimates of future demand for natural gas;



---

## Table of Contents

- when demand for natural gas increases, competition to build new LNG regasification capacity may heighten because new capacity may be more profitable, with a lower marginal cost of production;
- when LNG regasification capacity significantly increases, the competition for the receipt and regasification of LNG increases;
- under-supplies at the foreign supply source of LNG also increase competition among LNG terminals and may cause LNG receiving terminal operators to compete aggressively on price in order to maximize capacity utilization;
- when demand for LNG receiving capacity decreases, the high fixed cost structure of capital-intensive LNG receiving terminals causes producers and transporters of natural gas to compete aggressively on price in order to maximize capacity utilization;
- substantial increases in the receiving capacity of LNG receiving terminals will substantially increase the potential supply of natural gas to U.S. markets, which could substantially amplify the downswings related to the over-supply of available natural gas;
- supplies of, and prices for, alternative energy sources such as coal, oil, nuclear, hydroelectric, wind and solar energy cause changes in the demand for natural gas;
- as competition in natural gas is focused on price, being a low-cost supplier is critical to profitability. This would favor the construction of larger LNG receiving facilities, which maximize economies of scale, but also could cause an increase in capacity that can outstrip the existing growth in demand for natural gas; and
- cyclical trends in general business and economic conditions cause changes in the demand for natural gas.

The increases and decreases in the available supply of natural gas as a result of changes in available LNG receiving capacity available could materially adversely affect our business, results of operations, financial condition and prospects.

***We may have difficulty obtaining enough customers for regasification capacity at our proposed LNG receiving terminals to implement and complete our business plan. We may change our business strategy as to how and when we market our capacity.***

Our current marketing strategy calls for us to enter into long-term TUAs covering approximately 4 Bcf/d of our total existing and future regasification capacity at our LNG receiving terminals, including a commitment to pay capacity reservation fees, prior to the commencement of construction of each facility. The portion of our total regasification capacity that we plan to commit under such long-term TUAs has changed in the past and may change in the future for various reasons, including responding to market factors or perceived opportunities that we believe may be available to us. Our ability to obtain project-level financing for each LNG receiving facility may be contingent on our ability to enter into long-term TUAs covering approximately 4 Bcf/d of regasification capacity in advance of the commencement of construction. In addition, we anticipate that we will be able to rely on these capacity reservation fee payments to cover a portion of operating costs prior to commencement of operations at our proposed LNG receiving terminals. As of the date of this filing, we do not have any TUAs in place for either our proposed Corpus Christi facility or our proposed Creole Trail facility nor do we have any contracts in place for the use of our pipelines.

We may experience difficulty attracting additional customers because we are a small, developing company with no operating history in the LNG business. In order to succeed, we must convince additional potential customers, among other things, that we will be able to secure adequate financing for the construction of the LNG receiving terminal sites and natural gas pipelines that we are developing and that they will be approved by appropriate governmental agencies. We may also change our marketing strategy due to our inability to enter into TUAs prior to construction and our view regarding future prices, demand and supply of natural gas and regasification capacity. If these marketing efforts are not successful, our business, results of operations, financial condition and prospects could be materially adversely affected.

---

## **Table of Contents**

***Failure of imported LNG to become a competitive source of energy in the United States could have a detrimental effect on our ability to implement and complete our business plan.***

In the United States, due mainly to an abundant supply of natural gas, imported LNG has not historically been a major energy source. Our business plan is based on the belief that LNG can be produced and delivered to the United States at a lower cost than the cost to produce some domestic supplies of natural gas, or other alternative energy sources. Through the use of improved exploration technologies, additional sources of natural gas may be discovered in North America, which would further increase the available supply of natural gas at a lower cost than LNG. In addition to natural gas, LNG also competes with other sources of energy, including coal, oil, nuclear, hydroelectric, wind and solar energy. As a result, LNG may not become a competitive source of energy in the United States. The failure of LNG to become a competitive supply alternative to domestic natural gas, oil and other import alternatives could have a material adverse effect on our business, results of operations, financial condition and prospects.

***The inability to import LNG into the United States due to, among other things, governmental regulation or potential instability in countries that supply natural gas, could materially adversely affect our business plans and results of operations.***

Upon completion of the LNG receiving terminals, our business will be dependent upon the ability of our third-party customers and Cheniere Marketing to import LNG supplies into the United States. Political instability in foreign countries that have supplies of natural gas, or strained relations between such countries and the United States, may impede the willingness or ability of LNG suppliers in such countries to export LNG to the United States. Such foreign suppliers may also be able to negotiate more favorable prices with other LNG customers around the world than with us and other customers in the United States, thereby reducing the supply of LNG available to be imported into the United States market. In addition, we believe that the existing fleet of tankers that is available to transport LNG is inadequate, and the failure to expand LNG tanker capacity would impede both our and our customers' ability to import LNG into the United States. Any significant impediment to the ability to import LNG into the United States could have a material adverse effect on our business, results of operations, financial condition and prospects.

***Decreases in the price of natural gas in North America could harm our ability to develop our proposed LNG receiving terminals and market the sale of natural gas.***

The development of domestic LNG receiving terminals is based on assumptions about the future price of natural gas and the availability of imported LNG. The willingness of potential customers to contract for regasification capacity would be negatively impacted and, once facilities are in operation, LNG throughput volumes would likely decline if the price of natural gas in North America is, or is forecasted to be, lower than the cost to produce and deliver LNG to North American markets. Any significant decline in the price of natural gas could cause the cost of natural gas produced from imported LNG to be higher than domestically produced natural gas. As a result, any significant decline in the price of natural gas could have a material adverse effect on our business, results of operations, financial condition and prospects.

Natural gas prices have been, and are likely to continue to be, volatile and subject to wide fluctuations in response to any of the following factors:

- relatively minor changes in the supply of, and demand for, natural gas;
- political conditions in international natural gas producing regions;
- the extent of domestic production and importation of natural gas in relevant markets;
- the level of consumer demand;
- weather conditions;
- the competitive position of natural gas as a source of energy as compared with other energy sources; and
- the effect of federal and state regulation on the production, transportation and sale of natural gas.

---

## **Table of Contents**

***Our TUAs are subject to termination by our contractual counterparties under certain circumstances, and we are generally dependent on the performance of those counterparties under the TUAs.***

Sabine Pass LNG has entered into long-term TUAs with subsidiaries of Total S.A. and Chevron. Each of the TUAs contains various termination rights. For example, Total may terminate its TUA with Sabine Pass LNG if Sabine Pass LNG fails to deliver a specified amount of natural gas nominations or fails to receive or unload a specified number of cargoes. In addition, in the case of each of our TUAs, we are dependent on the respective counterparties' creditworthiness and their continued willingness to perform their obligations under the TUAs. If any of these counterparties fails to perform its obligations under its respective TUA, our business, results of operations, financial condition and prospects could be materially adversely affected, even if we were to be ultimately successful in seeking damages from that counterparty for a breach of the TUA.

***The construction of our proposed LNG receiving terminals will be dependent on performance by, and our relationship with, the contractors that we engage at each facility.***

Sabine Pass LNG entered into an EPC agreement in December 2004 with Bechtel. We also plan to enter into contracts with a major international EPC contractor for the construction of our proposed Corpus Christi and Creole Trail LNG receiving terminals. The success of our LNG receiving terminal development projects is highly dependent on our ability to enter into acceptable contracts with reputable EPC contractors and other contractors performing portions of the construction on our projects and for such contractors to perform their obligations under the contracts, including completing the projects on a timely basis. However, we may not be able to enter into acceptable contracts for the construction of Phase 2 of our Sabine Pass LNG receiving terminal or our proposed Corpus Christi or Creole Trail LNG receiving terminals. Other than with respect to Phase 1 of our Sabine Pass LNG receiving terminal, we have no prior experience working with any EPC contractor, including Bechtel, or other construction contractor. We may encounter unexpected delays or problems in connection with the construction of any of our proposed LNG receiving terminals. In addition, any EPC agreement could be terminated by an EPC contractor under certain circumstances prior to completion of construction. For example, see the description of the termination provisions of the EPC agreement with Bechtel under “—LNG Receiving Terminal Development Business—Our LNG Receiving Terminals—Sabine Pass LNG—EPC Agreement” above. If our relationship with any initial EPC contractor fails for any reason, we would be forced to engage a substitute contractor, which would likely result in a significant delay in our development schedule and could have a material adverse effect on our business, results of operations, financial condition and prospects.

### **Risks Relating to Our Pipeline Development Business**

***Expanding our business by constructing pipelines subjects us to risks.***

The construction of a new pipeline involves numerous regulatory, environmental, political and legal uncertainties beyond our control and requires the expenditure of significant amounts of capital that we will be required to finance through borrowings, through the issuance of additional equity or from operating cash flow. If we undertake these projects, they may not be completed on schedule or at all or at the budgeted cost. For instance, if we build a new pipeline, the construction will occur over an extended period of time, and we will not receive any revenues until the pipeline has been completed and customers pay for transportation service on the pipeline. Moreover, we may construct pipelines to capture anticipated future growth in a region in which such growth does not materialize. As a result, our pipelines may not be able to attract enough throughput to achieve our expected investment return, which could adversely affect our results of operations and financial condition. The success of our pipeline construction project may depend upon the level of LNG import activity in the areas proposed to be serviced by the project as well as our ability to obtain commitments from LNG suppliers and other customers to utilize the newly constructed pipelines.

***Failure to obtain and maintain approvals and permits from governmental and regulatory agencies with respect to the development of our pipelines would have a detrimental effect on us and our LNG projects.***

The design, construction and operation of natural gas pipelines and the transportation of natural gas are all highly regulated activities. FERC approval under Section 7 of the NGA, as well as several other material state

---

## Table of Contents

governmental and regulatory approvals and permits, is required in order to construct and operate our proposed pipelines. We have obtained authorization from FERC pursuant to Section 7(c) of the NGA to construct and operate our Sabine Pass and Corpus Christi pipelines, subject to certain conditions. However, we have not yet received authorization from FERC to construct and operate our Creole Trail pipelines. We also have not obtained several other material governmental and regulatory approvals and permits required in order to construct and operate our proposed pipelines. We have no control over the timing of the review and approval process nor can we predict the outcome of the process. We do not know whether or when any such approvals or permits can be obtained, or whether or not any third parties will attempt to interfere with our ability to obtain and maintain such permits or approvals. If we are unable to obtain and maintain the necessary approvals and permits, we may not be able to recover our investment in the projects. Failure to obtain and maintain any of these approvals and permits could have a material adverse effect on our business, results of operations, financial condition and prospects.

***Our proposed pipelines will be subject to FERC rate-making, which could have an adverse impact on our ability to recover the full cost of operating our pipelines, including a reasonable return.***

Our FERC tariffs will contain *pro forma* transportation agreements which must be filed and approved by FERC. Before we enter into a transportation agreement with a shipper that contains a term that materially deviates from our tariff, we must seek FERC approval. FERC may approve the material deviation in the transportation agreement; however, in that case, the materially deviating terms must be made available to our other customers. If we fail to seek FERC approval of a transportation agreement that materially deviates from our tariff or if FERC audits our contracts and finds deviations that appear to be unduly discriminatory, FERC could conduct a formal enforcement investigation, resulting in serious penalties and/or onerous ongoing compliance obligations.

Should we fail to comply with all applicable FERC-administered statutes, rules, regulations and orders, we could be subject to substantial penalties and fines. Under the recently enacted Energy Policy Act of 2005, FERC has civil penalty authority under the NGA to impose penalties for current violations of up to \$1 million per day for each violation.

FERC could change its current ratemaking policies, and those changes could have adverse effects on our proposed pipelines.

***Any reduction in the capacity of, or the allocations to, interconnecting, third-party pipelines could cause a reduction of volumes transported in our proposed pipelines, which would adversely affect our revenues and cash flow.***

We will depend upon third-party pipelines and other facilities that will provide delivery options to and from our proposed pipelines. If any pipeline connection were to become unavailable for volumes of natural gas due to repairs, damage to the facility, lack of capacity or any other reason, our ability to continue shipping natural gas to end markets could be restricted, thereby reducing our revenues. Any temporary or permanent interruption at any key pipeline interconnect which caused a material reduction in volumes transported on our proposed pipelines could have a material adverse effect on our business, results of operations and financial condition.

***Our pipeline business could be materially adversely affected if we lose the right to situate our proposed pipelines on property owned by third parties.***

We do not anticipate owning the land on which our proposed pipelines will be constructed, and we are subject to the possibility of increased costs to obtain and retain necessary land use. We anticipate obtaining the right to construct and operate the pipelines on land owned by third parties for a period of time. If we were to lose these rights or be required to relocate our pipelines, our business could be materially adversely affected.

---

## **Table of Contents**

### ***Pipeline safety integrity programs and repairs may impose significant costs and liabilities on us.***

The OPS has issued a final rule requiring pipeline operators to develop integrity management programs to comprehensively evaluate certain areas along their pipelines and take additional measures to protect pipeline segments located in what the rule refers to as “high consequence areas” where a leak or rupture could potentially do the most harm. The final rule requires operators to:

- perform ongoing assessments of pipeline integrity;
- identify and characterize applicable threats to pipeline segments that could impact a high consequence area;
- improve data collection, integration and analysis;
- repair and remediate the pipeline as necessary; and
- implement preventive and mitigating actions.

We will be required to initiate pipeline integrity testing programs that are intended to assess pipeline integrity. The rule, or an increase in public expectations for pipeline safety, may require additional reporting and more frequent inspection or testing of our proposed pipeline facilities. Any repair, remediation, preventative or mitigating actions may require significant capital and operating expenditures. Should we fail to comply with OPS rules, and related regulations and orders, we could be subject to penalties and fines.

### ***Because our proposed pipelines will be dependent upon a few customers, including an affiliate, for a significant portion of the revenues anticipated to be generated by our pipeline business, our business may be materially and adversely affected if we lose any one of these customers.***

We do not currently have any third-party customers for our pipelines. We anticipate that customers with whom we enter into TUAs for our LNG receiving terminals will enter into agreements for the transportation of revaporized gas on our proposed pipelines. However, the number of such customers is anticipated to be limited, and we anticipate being substantially dependent on them for a significant percentage of the revenues generated by our pipeline business. In addition, the largest customer of our proposed pipelines is anticipated to be our affiliate, Cheniere Marketing. The loss of any of these customers, a decline in their creditworthiness or a substantial reduction in their shipments on our proposed pipelines, could have a material adverse effect on our business, results of operations and financial condition.

### **Risks Relating to Our LNG and Natural Gas Marketing Business**

#### ***We are in the early stages of developing our LNG and natural gas marketing business.***

We have just recently begun developing our LNG and natural gas marketing business. To date, the business has only a few employees, has generated no revenues and has no operating history upon which you can evaluate our business strategy or the future prospects of the business. The ability of our LNG and natural gas marketing business to generate revenues in the future will depend upon whether we can successfully develop and implement our business strategy and make the transition from a development stage business to an operating business. We may encounter many expenses, delays, problems and difficulties that we have not anticipated and for which we have not planned in developing and operating our LNG and natural gas marketing business.

#### ***Our use of hedging arrangements may adversely affect our future results of operations or liquidity.***

To reduce our exposure to fluctuations in the price, volume, timing, location, quality and credit risk associated with the marketing of LNG and natural gas, we may use futures, swaps and option contracts traded on NYMEX, over-the-counter options and swaps with other natural gas merchants and financial institutions. Hedging arrangements would expose us to risk of financial loss in some circumstances, including when:

- expected supply is less than the amount hedged;
- the counterparty to the hedging contract defaults on its contractual obligations; or

---

## Table of Contents

- there is a change in the expected differential between the underlying price in the hedging agreement and actual prices received.

Our hedging arrangements may also limit the benefit that we would receive from increases in the prices for natural gas. The use of derivatives also may require the posting of cash collateral with counterparties, which can impact working capital when commodity prices change.

***If we do not attract and retain qualified personnel for our developing LNG and natural gas marketing business, our operations could be adversely affected.***

Our success in developing and operating an LNG and natural gas marketing business will be, in part, dependent upon the number and quality of personnel that we can hire and our ability to maintain good relationships with them. We anticipate that we will need to hire additional employees to conduct our natural gas marketing activities. If we are unable to retain qualified employees and then successfully maintain good relationships with them, our results of operations may be adversely affected.

***Other risks related to our LNG receiving terminal development business could have similar adverse effects on our marketing business.***

Some of the risks described above under “—Risks Relating to Our LNG Receiving Terminal Development Business” could have an adverse impact on our marketing business, including those set forth under the following headings:

- “Cyclical changes in the demand for LNG regasification capacity may result in reduced operating revenues and may cause operating losses in the future;”
- “Failure of imported LNG to become a competitive source of energy in the United States could have a detrimental effect on our ability to implement and complete our business plan;”
- “The inability to import LNG into the United States due to, among other things, governmental regulation or potential instability in countries that supply natural gas, could materially adversely affect our business plans and results of operations;” and
- “Decreases in the price of natural gas in North America could harm our ability to develop our proposed LNG receiving terminals and market the sale of natural gas.”

### **Risks Relating to Our Oil and Gas Exploration and Development Business**

***We are subject to significant exploration risks, including the risk that we may not be able to find or produce enough oil and gas to generate any profits.***

Our exploration activities involve significant risks, including the risk that we may not be able to find or produce enough oil and gas to generate any profits. The wells we drill may not discover any oil or gas. Furthermore, there is no way to know in advance of drilling and testing whether any prospect will yield oil or gas in sufficient quantities to make money for us. In addition, we are highly dependent on seismic activity and the related application of new technology as a primary exploration methodology. This methodology, however, requires greater pre-drilling expenditures than traditional drilling strategies. Even when fully used and properly interpreted, 3D seismic data can only assist us in identifying subsurface reservoirs and hydrocarbon indicators, and will not allow us to determine conclusively if hydrocarbons will in fact be present and recoverable. If our exploration efforts are unsuccessful, our business, results of operations, financial condition and prospects could be materially adversely affected.

***We may not be able to acquire the oil and gas leases we need to sustain profitable operations.***

In order to engage in oil and gas exploration in the areas covered by our 3D seismic data, we must first acquire rights to conduct exploration and recovery activities on such properties. We may not be successful in

---

## **Table of Contents**

acquiring farm-outs (agreements whereby the owner of lease interests grants to a third party the right to earn an assignment of an interest in the lease, typically by drilling one or more wells), seismic permits, lease options, leases or other rights to explore for or recover oil and gas. Both the U.S. Department of the Interior and the States of Texas and Louisiana award oil and gas leases on a competitive bidding basis. Non-governmental owners of the onshore mineral interests within the area covered by our exploration program are not obligated to lease their mineral rights to us except where we have already obtained lease options. In addition, other major and independent oil and gas companies with financial resources significantly greater than ours may bid against us for the purchase of oil and gas leases. If we are unsuccessful in acquiring these leases, permits, options and other interests, the area covered by our 3D seismic data that could be explored through drilling will be significantly reduced, and our business, results of operations, financial condition and prospects could be materially adversely effected.

***If we are unable to obtain satisfactory turnkey contracts, we may have to assume additional risks and expenses when drilling wells.***

We anticipate that any wells drilled in which we have an interest will be drilled by established industry contractors under turnkey contracts that limit our financial and legal exposure. Under a turnkey drilling contract, a negotiated price is agreed upon and the money placed in escrow. The contractor then assumes all of the risk and expense, including any cost overruns, of drilling a well to contract depth and completing any agreed upon evaluation of the wellbore. Upon performance of all these items, the escrowed money is released to the contractor.

Circumstances may arise, however, where a turnkey contract is not economically beneficial to us or is otherwise unobtainable from proven industry contractors. In such instances, we may decide to drill wells on a day-rate basis. Under a day-rate drilling contract, the operator pays an agreed sum for each day of drilling required to reach contract depth. All risk and expense of drilling a well to total depths lies with the operator in day-rate contracts. The drilling of such test wells would subject us to the usual drilling hazards such as cratering, explosions, uncontrollable flows of oil, gas or well fluids, fires, pollution and other environmental risks. We would also be liable for any cost overruns attributable to drilling problems that otherwise would have been covered by a turnkey contract. These liabilities, if incurred, could have a materially adverse effect on our business, results of operations, financial condition and prospects.

***If we are unsuccessful at marketing our oil and gas at commercially acceptable prices, our profitability will decline.***

Our ability to market oil and gas at commercially acceptable prices depends on, among other factors, the following:

- the availability and capacity of gathering systems and pipelines;
- federal and state regulation of production and transportation;
- changes in supply and demand; and
- general economic conditions.

Our inability to respond appropriately to changes in these factors could have a material adverse effect on our business, results of operations, financial condition and prospects.

***Shortage of rigs, equipment, supplies or personnel may restrict our operations.***

Our industry is cyclical and, from time to time, there is a shortage of drilling rigs, equipment, supplies or personnel. During these periods, the costs and delivery times of rigs, equipment and supplies are substantially greater. In addition, demand for, and wage rates of, qualified drilling rig crews rises with increases in the number

---

## Table of Contents

of active rigs in service. Shortages of drilling rigs, equipment or supplies could delay or restrict our exploration and development operations, which in turn could have a material adverse effect on our business, results of operations, financial condition and prospects.

*We depend on industry partners and could be seriously harmed if they do not perform satisfactorily, which is usually not within our control.*

Because our oil and gas exploration and development business has few employees and limited operating revenues, we are and will continue to be largely dependent on industry partners for the success of our oil and gas exploration projects. We could be seriously harmed if we fail to attract industry partners to participate in the drilling of prospects which we identify or if our industry partners do not perform satisfactorily on projects that affect us. We often have and will continue to have no control over factors that would influence the performance of our partners.

*There are numerous uncertainties inherent in estimating quantities of proved oil and gas reserves and future net cash flows.*

Numerous uncertainties, including those beyond our control, are inherent in estimating quantities of proved oil and gas reserves. Information included herein for 2005 relating to estimates of our proved reserves is based on reports prepared by Sharp Petroleum Engineering, Inc. Reserve engineering is a subjective process of estimating underground accumulations of oil and gas that cannot be measured in an exact manner. Estimates of economically recoverable oil and gas reserves and of future net cash flows may vary considerably from the actual results because of a number of variable factors and assumptions involved. These include:

- historical production from the area compared with production from other producing areas;
- the effects of regulation by governmental agencies;
- future oil and gas prices;
- operating costs;
- severance and excise taxes;
- development costs; and
- workover and remedial costs.

Therefore, the estimates of the quantities of oil and gas and the expected future net cash flows computed by different engineers or by the same engineers (but at different times) may vary significantly. The actual production, revenues and expenditures related to our reserves may vary materially from the engineers' estimates. In addition, we may make changes to our estimates of reserves and future net cash flows. These changes may be based on the following factors:

- production history;
- results of future development;
- oil and gas prices;
- performance of counterparties under agreements to which we are a party; and
- operating and development costs.

Do not interpret the PV-10 values included in this Form 10-K as the current market value of our properties' estimated oil and gas reserves. According to the SEC, the PV-10 is generally based on prices and costs as of the date of the estimate. In contrast, the actual future prices and costs may be materially higher or lower. Actual future net cash flows may also be affected by the following factors:

- the amount and timing of actual production;
- the supply of, and demand for, oil and gas;



---

## Table of Contents

- the curtailment or increases in consumption by natural gas purchasers; and
- the changes in governmental regulations or taxation.

The timing in producing and the costs incurred in developing and producing oil and gas will affect the timing of actual future net cash flows from proved reserves. Ultimately, the timing will affect the actual present value of oil and gas. In addition, the SEC requires that we apply a 10% discount factor in calculating PV-10 for reporting purposes. This is not necessarily the most appropriate discount factor to apply because it does not take into account the interest rates in effect, the risks associated with us and our properties, or the oil and gas industry in general.

***Because of our lack of diversification, factors harming the oil and gas industry in general, including downturns in prices for oil and gas, would be especially harmful to us.***

We are an independent energy company and are not actively engaged in any other industry. Our revenues and results of operation are substantially dependent on the oil and gas industry in general and the prevailing prices for oil and gas in particular. Circumstances that harm the oil and gas industry in general will have an especially harmful effect on us. Oil and gas prices have been and are likely to continue to be volatile and subject to wide fluctuations in response to any of the following factors:

- relatively minor changes in the supply of and demand for oil and gas;
- political conditions in international oil producing regions;
- the extent of domestic production and importation of oil in relevant markets;
- the level of consumer demand;
- weather conditions;
- the competitive position of oil or gas as a source of energy as compared with other energy sources;
- the refining capacity of oil purchasers; and
- the effect of federal and state regulation on the production, transportation and sale of oil and gas.

It is likely that adverse changes in the oil and gas market or the regulatory environment would have an adverse effect on our business, results of operations, financial condition and prospects, including our ability to develop and implement our LNG project and to obtain capital from lending institutions, industry participants, private or public investors or other sources.

### **Risks Relating to Our Business in General**

***We are currently a small, developing company with limited operating history in the businesses that we are developing. Our business plans are contingent on our ability to manage successfully our anticipated expansion and transition to operating these businesses.***

As of February 28, 2006, we had 130 full-time employees, who, for the most part, are focused on the pre-construction stages of the development of our three proposed LNG receiving terminals. As we begin construction of the LNG receiving terminals, we will have to hire new onsite employees to manage the construction of each facility. Before our proposed LNG receiving terminals commence operations, we will have to hire an entire staff to operate each facility. We have no experience in the construction or operation of LNG receiving terminals or pipelines or the marketing of LNG or natural gas, and, as a result, we will be forced to rely to a significant extent on the new employees we hire to perform these functions. During 2006, we anticipate hiring approximately 110 employees. As our operations expand, we will also have to expand our administrative staff. If we are not able to successfully manage the expansion of our business, our business, results of operation, financial condition and prospects could be materially adversely affected.

---

## Table of Contents

***Our initiatives to pursue downstream and upstream opportunities as part of our overall energy business strategy may not be successful and, even if successful, could expose use to greater and unanticipated risks.***

We have little or no prior experience in some of the downstream opportunities that we are pursuing, such as natural gas pipeline development or natural gas marketing. We also have limited experience in some of the upstream opportunities that we are pursuing, such as investment in LNG shipping businesses and oil and gas exploration, development and transportation. Similarly, we have little or no prior experience in other upstream opportunities that we are pursuing, such as securing foreign LNG supply arrangements and developing foreign natural gas reserves that could be converted into LNG and imported into either domestic or international markets. We may not be successful in our efforts to pursue any or all of these initiatives. If we are successful in pursuing one or more of these downstream or upstream opportunities, we will likely incur greater risks than we expect to incur in our LNG receiving terminal business, and some of those risks we will not be able to anticipate.

***We depend on key personnel, and we could be seriously harmed if we lost their services.***

We depend on our executive officers for various activities. We do not maintain key person life insurance policies on any of our personnel. Although we have agreements relating to compensation and benefits with certain of our executive officers, we do not have any employment contracts or other agreements with key personnel binding them to provide services for any particular term. The loss of the services of any of these individuals could seriously harm us. In addition, our future success will depend in part on our ability to attract and retain additional qualified personnel.

***We are subject to significant operating hazards and uninsured risks, one or more of which may create significant liabilities for us.***

The construction and operation of our proposed LNG receiving terminals and pipelines will be subject to the inherent risks normally associated with these types of operations, including explosions, pollution, release of toxic substances, fires, hurricanes and adverse weather conditions and other hazards, each of which could result in a significant delay in the timing of commencement of operations and/or in damage to or destruction of our facilities or damage to persons and property. In addition, our operations face possible risks associated with acts of aggression or terrorism on our facilities and the facilities and tankers of third parties on which our operations are dependent.

In accordance with customary industry practices, we intend to maintain insurance against some, but not all, of these risks and losses. We may not be able to maintain insurance (as our project lenders may require) in the future at rates that we consider reasonable. The occurrence of a significant event not fully insured or indemnified against could have a material adverse effect on our business, results of operations, financial condition and prospects.

***Existing and future United States governmental regulation, taxation and price controls could seriously harm us.***

Our LNG receiving terminal and pipeline businesses are subject to extensive federal, state and local laws and regulations that regulate the discharge of materials into the environment or otherwise relate to the protection of the environment. Failure to comply with such rules and regulations can result in substantial penalties and may harm us. Present, as well as future, legislation and regulations could cause additional expenditures, restrictions and delays in our business, the extent of which cannot be predicted and which may require us to limit substantially, delay or cease operations in some circumstances.

The construction and operation of our LNG receiving terminals and pipelines are subject to issuance of necessary permits, licenses, consultations and approvals from numerous federal agencies, including from FERC under Section 3 of the NGA. The costs that we incur to obtain and maintain FERC and other governmental

---

## Table of Contents

approvals authorizing us to commence construction of our proposed LNG receiving terminals and pipelines and to comply with the ongoing regulation of the operation and maintenance of such terminals and pipelines could have a material adverse effect on our business, results of operations, financial condition and prospects. In addition, delay in the receipt of, or modification or other regulatory action with respect to, FERC or other required governmental authorization could cause substantial delays in the commencement of construction or operations of our LNG receiving terminals or pipelines, increased costs or even result in the cessation of operations. Any interstate pipeline transmission system connected to our LNG receiving terminals, as will be the case with each of our LNG receiving terminals, is subject to FERC regulation under Section 7 of the NGA. Such regulation may restrict the ability of our customers to transport gas to and from our terminals, which could have a material adverse effect on our business, results of operations, financial condition and prospects. FERC has in the past regulated the prices at which natural gas could be sold. Federal reenactment of price controls or increased regulation of the transport of natural gas could have a material adverse effect on our business, results of operations, financial condition and prospects.

Our LNG receiving terminal and pipeline development businesses are also subject to extensive federal, state and local laws and regulations governing the discharge of natural gas, hazardous substances, materials and other compounds into the environment or otherwise relating to environmental protection. These laws and regulations may restrict or prohibit the types, quantities and concentration of substances that can be released into the environment and impose substantial liabilities for pollution or releases of hazardous substances, materials or compounds or impose conditions that require additional costs or changes in operations that could have a material adverse effect on our business, results of operations, financial condition and prospects. Failure to comply with these laws and regulations may also result in civil and criminal fines and penalties. Moreover, state and federal environmental laws and regulations may become more stringent.

Federal laws and regulations such as CERCLA, the CAA, the OPA and the CWA, and analogous state laws have regularly imposed increasingly strict requirements for water and air pollution control, hazardous waste and materials management and strict financial responsibility and remedial response obligations. The cost of complying with such environmental legislation could have a material adverse effect on our business, results of operations, financial condition and prospects.

Existing environmental laws and regulations may be revised or reinterpreted or new laws and regulations may be adopted or become applicable to us. Revised, reinterpreted or additional laws and regulations that result in increased compliance costs or additional operating restrictions could have a material adverse effect on our business, results of operations, financial condition and prospects.

***Some of our economic value is derived from our ownership of minority interests in entities over which we exercise no day-to-day control.***

We own a 30% limited partner interest in Freeport LNG and a minority interest in J & S Cheniere. Some of our value is attributable to these investments. In this annual report, we may use the words “our,” “we” or “us” in describing these investments or their assets and operations; however, we do not exercise control over Freeport LNG or J & S Cheniere. The management team of Freeport LNG or J & S Cheniere could make business decisions without our consent that could impair the economic value of our investments in those entities. Any such diminution in the value of either investment could have an adverse impact on our business, results of operations, financial condition and prospects.

***We may have to take actions that are disruptive to our business strategy to avoid registration under the Investment Company Act of 1940.***

The Investment Company Act of 1940, or Investment Company Act, requires registration for companies that are engaged primarily in the business of investing, reinvesting, owning, holding or trading in securities. Registration as an investment company would subject us to restrictions that are inconsistent with our fundamental business strategy.

---

## **Table of Contents**

A company may be deemed to be an investment company if it owns investment securities with a value exceeding 40% of the value of its total assets (excluding government securities and cash items) on an unconsolidated basis, unless an exemption or safe harbor applies. Securities issued by companies other than majority-owned subsidiaries are generally counted as investment securities for purposes of the Investment Company Act. We own minority equity interests in certain entities that could be counted as investment securities. We generally plan to invest our liquid assets in commercial paper or other assets that may be considered investment securities in order to achieve higher yields from our available funds than investments in government securities and money market or similar cash investments would provide. Based on our board of directors' determination of the value of our subsidiaries, we estimate that less than 40% of our assets consist of investment securities. However, in the event we acquire additional investment securities in the future, or if the value of our interests in companies that we do not control were to increase relative to the value of our controlled subsidiaries, we might be required to invest some portion of our liquid assets in government securities or cash items that yield lower returns than our proposed investments, or, in the alternative, we might be required to divest some of our non-controlled business interests, or take other action, in order to avoid being classified as an investment company.

***We plan to engage in operations and make investments outside the United States, which would expose us to political, governmental and economic instability and foreign currency exchange rate fluctuations.***

Conducting operations or making investments outside of the United States will cause us to be affected by economic, political and governmental conditions in the countries where we engage in business. Any disruption caused by these factors could harm our business. Risks associated with operations and investments outside of the United States include risks of:

- currency fluctuations;
- war;
- expropriation or nationalization of assets;
- renegotiation or nullification of existing contracts;
- changing political conditions;
- changing laws and policies affecting trade, taxation and investment;
- multiple taxation due to different tax structures; and
- the general hazards associated with the assertion of sovereignty over certain areas in which operations are conducted.

Because our reporting currency is the United States dollar, any of our operations outside the United States would face additional risks of fluctuating currency values and exchange rates, hard currency shortages and controls on currency exchange. We would be subject to the impact of foreign currency fluctuations and exchange rate changes on our reporting for results from those operations in our financial statements.

***Terrorist attacks or sustained military campaigns may adversely impact our business.***

The terrorist attacks that took place in the United States on September 11, 2001 were unprecedented events that have created many economic and political uncertainties, some of which may materially adversely impact our business. The continued threat of terrorism and the impact of military and other action will likely lead to continued volatility in prices for natural gas and could affect the markets for the operations of our LNG customers on which we will be dependent, as well as lead to increased costs incurred by us in implementing security measures against such threats. Furthermore, the United States government has issued public warnings that indicate that pipelines and other energy assets might be specific targets of terrorist organizations. These potential targets might include our assets. The continuation of these developments may subject our operations to increased risks, as well as increased costs, and, depending on their ultimate magnitude, could have a material adverse effect on our business, results of operations, financial condition and prospects.

---

## Table of Contents

### ***Hurricanes Katrina and Rita, or future similar storms, could have a material adverse effect on our business, financial condition and results of operations.***

In August and September of 2005, Hurricanes Katrina and Rita and related storm activity, such as windstorms, storm surges, floods and tornadoes, caused extensive and catastrophic physical damage in and to coastal and inland areas located in the Gulf Coast region of the United States (parts of Texas, Louisiana, Mississippi and Alabama) and certain other parts of the southeastern United States. Construction at our Sabine Pass terminal site was temporarily suspended in connection with Hurricane Katrina, as a precautionary measure. Approximately three weeks after the occurrence of Hurricane Katrina, the terminal site was again secured and evacuated in anticipation of Hurricane Rita, the eye of which made landfall to the east of the site.

Bechtel has claimed events of *force majeure* arising out of three hurricanes in 2005 along the U.S. Gulf Coast. Sabine Pass LNG is currently in negotiations with Bechtel and certain subcontractors concerning additional activities and expenditures in order, among other things, to attract sufficient skilled labor to mitigate potential schedule delays and provide a reasonable opportunity for Bechtel to attain the initial target bonus date of April 3, 2008 (the date originally anticipated for completion of construction sufficient to achieve a sendout rate of at least 2.0 Bcf/d for a minimum sustained test period of 24 hours and that, if attained, would entitle Bechtel to a scheduled \$12 million bonus). As part of these negotiations, we have agreed in principle to defer the date by which substantial completion of the entire project is required to be accomplished under the EPC contract from September 3 to December 20, 2008. In the absence of substantial completion by such date, Bechtel would be obligated to pay us certain liquidated damages as provided under the terms of the contract. We expect that the above-described arrangement will not exceed \$50 million, although such amount is subject to change, requires approval of the lenders under our Sabine Pass Credit Facility and requires that a change order be agreed upon with Bechtel. These storms and their collateral effects, mainly labor availability, could result in additional delays or cost increases for construction of our Sabine Pass LNG receiving terminal.

Future similar storms and related storm activity and collateral effects could result in damage to, delays or cost increases in construction of, or interruption of operations at, our planned LNG receiving terminals or related pipelines.

#### **ITEM 1B. UNRESOLVED STAFF COMMENTS**

None.

#### **ITEM 3. LEGAL PROCEEDINGS**

We are, and may in the future be, involved as a party to various legal proceedings, which are incidental to the ordinary course of business. We regularly analyze current information and, as necessary, provide accruals for probable liabilities on the eventual disposition of these matters. In the opinion of management and legal counsel, as of December 31, 2005, there were no threatened or pending legal matters that would have a material impact on our consolidated results of operations, financial position or cash flows.

As previously disclosed, we received a letter dated December 17, 2004 advising us of a nonpublic, informal inquiry being conducted by the SEC. On August 9, 2005, the SEC informed us that it had issued a formal order and commenced a nonpublic factual investigation of actions and communications by Cheniere, its current or former directors, officers and employees and other persons in connection with our agreements and negotiations with Chevron USA, the Company's December 2004 public offering of common stock, and trading in our securities. The scope, focus and subject matter of the SEC investigation may change from time to time, and we may be unaware of matters under consideration by the SEC. We have cooperated fully with the SEC informal inquiry and intend to continue cooperating fully with the SEC in its investigation.

## [Table of Contents](#)

Neither Cheniere, nor any entity required to be consolidated with Cheniere for purposes of this annual report, has been required to pay a penalty to the Internal Revenue Service for failing to make disclosures required with respect to certain transactions that have been identified by the Internal Revenue Service as abusive or that have a significant tax avoidance.

### **ITEM 4. SUBMISSION OF MATTERS TO A VOTE OF SECURITY HOLDERS**

None.

## **PART II**

### **ITEM 5. MARKET PRICE FOR REGISTRANT'S COMMON EQUITY, RELATED STOCKHOLDER MATTERS AND ISSUER PURCHASES OF EQUITY SECURITIES**

Our common stock has traded on the American Stock Exchange under the symbol LNG since March 24, 2003. The table below presents the high and low daily closing sales prices of the common stock, as reported by the American Stock Exchange, for each quarter during 2004 and 2005.

	<u>High</u>	<u>Low</u>
Three Months Ended		
March 31, 2004	\$ 9.54	\$ 5.55
June 30, 2004	10.42	5.53
September 30, 2004	10.42	8.12
December 31, 2004	32.35	10.06
Three Months Ended		
March 31, 2005	\$ 39.46	\$ 30.98
June 30, 2005	34.95	26.00
September 30, 2005	41.86	31.38
December 31, 2005	42.73	34.74

The above historical share prices have been adjusted to reflect our two-for-one stock split that occurred on April 22, 2005.

As of February 28, 2006, we had 54.7 million shares of common stock outstanding held by approximately 8,500 beneficial owners.

We have never paid a cash dividend on our common stock. We currently intend to retain earnings to finance the growth and development of our business and do not anticipate paying any cash dividends on the common stock in the foreseeable future. Any future change in our dividend policy will be made at the discretion of our board of directors in light of our financial condition, capital requirements, earnings, prospects and any restrictions under any credit agreements, as well as other factors the board of directors deems relevant.

[Table of Contents](#)

**ITEM 6. SELECTED FINANCIAL DATA**

Selected financial data set forth below are derived from our audited Consolidated Financial Statements for the periods indicated. The financial data should be read in conjunction with Management's Discussion and Analysis of Financial Condition and Results of Operations and our Consolidated Financial Statements and Notes thereto included elsewhere in this report.

	Year Ended December 31,				
	(in thousands, except per share data)				
	2005	2004	2003	2002	2001
Revenues	\$ 3,005	\$ 1,998	\$ 658	\$ 239	\$ 2,373
LNG terminal development expenses (1)	22,020	17,166	6,705	1,557	1,789
Depreciation, depletion and amortization	3,702	1,324	429	369	1,244
Ceiling test write-down	—	—	—	—	5,126
General and administrative expenses	29,145	12,476	2,542	1,918	2,504
Loss from operations	(52,099)	(29,085)	(9,018)	(3,695)	(8,710)
Equity in net loss of affiliate (2)	—	—	—	(2,185)	(2,974)
Gain on sale of investment in unconsolidated affiliate (2)	20,206	—	—	—	—
Equity in net loss of limited partnership (3)	(1,031)	(1,346)	(4,471)	—	—
Gain on sale of LNG assets	—	—	4,760	—	—
Reimbursement from limited partnership investment	—	2,500	—	—	—
Interest expense	(17,373)	—	—	—	—
Interest income	17,520	501	3	8	19
Minority interest (4)	97	2,862	3,015	—	—
Income tax benefit	2,045	—	—	—	—
Net loss	(29,798)	(24,568)	(5,288)	(5,632)	(11,665)
Net loss per share (basic and diluted) (5)	\$ (0.56)	\$ (0.63)	\$ (0.18)	\$ (0.21)	\$ (0.45)
Weighted average shares outstanding (basic and diluted) (5)	53,097	38,895	29,543	26,595	26,071

	December 31,				
	(in thousands, except per share data)				
	2005	2004	2003	2002	2001
Cash and cash equivalents	\$ 692,592	\$308,443	\$ 1,258	\$ 590	\$ 611
Restricted cash and cash equivalents	160,885	—	—	—	—
Working capital	810,141	305,752	155	(1,413)	(530)
Property, plant and equipment, net	298,083	20,880	20,024	19,211	19,932
Debt issuances costs, net	43,008	1,302	—	—	—
Goodwill	76,844	—	—	—	—
Total assets	1,308,124	333,567	24,591	21,059	25,024
Long-term debt	917,500	—	—	—	—
Total liabilities	980,606	5,628	4,332	3,262	1,874
Deferred revenue	41,000	23,000	1,000	—	—
Total stockholders' equity	286,518	304,601	19,139	17,797	23,149

- (1) The year ended 2002 includes \$1.7 million in recoveries of general and administrative expenses reimbursable under the term of an agreement related to our sale of the Freeport LNG site, which closed in February 2003. See Note 8 to our Consolidated Financial Statements.
- (2) Effective January 1, 2003, we began accounting for this investment in Gryphon using the cost method of accounting. The amounts listed for 2002 and 2001 represent our equity in the net loss of Gryphon under the equity method of accounting. In 2005, Gryphon was sold to Woodside Energy (USA), generating net cash proceeds and a gain to Cheniere of \$20.2 million. See Note 22 to our Consolidated Financial Statements.
- (3) Represents our equity in the net loss of Freeport LNG. See Note 8 to our Consolidated Financial Statements.
- (4) Represents minority interest in the net loss of Corpus Christi LNG. See Note 13 to our Consolidated Financial Statements.
- (5) Net loss per share and weighted average shares outstanding have been restated to reflect a two-for-one split that occurred on April 22, 2005.

**ITEM 7. MANAGEMENT'S DISCUSSION AND ANALYSIS OF FINANCIAL CONDITION AND RESULTS OF OPERATION**

**General**

We are engaged primarily in the business of developing and constructing, and then owning and operating, a network of three onshore LNG receiving terminals, and related natural gas pipelines, along the Gulf Coast of the United States. We are also engaged, to a limited extent, in oil and natural gas exploration and development activities in the Gulf of Mexico. We operate four business activities: LNG receiving terminal development, natural gas pipeline development, LNG and natural gas marketing and oil and gas exploration and development. At this stage in our development, our operations are divided into two reporting segments in our financial statements: LNG Receiving Terminal Development and Oil and Gas Exploration and Development.

**LNG Receiving Terminal Development Business**

We have focused our development efforts on three, 100% owned LNG receiving terminal projects at the following locations: Sabine Pass LNG in western Cameron Parish, Louisiana on the Sabine Pass Channel; Corpus Christi LNG near Corpus Christi, Texas; and Creole Trail LNG at the mouth of the Calcasieu Channel in central Cameron Parish, Louisiana. In addition, we own a 30% interest in a fourth project, Freeport LNG, located on Quintana Island near Freeport, Texas. Our three terminals have an aggregate designed regasification capacity of approximately 10 Bcf/d, subject to expansion. We have entered into long-term TUAs with Total and Chevron USA for an aggregate of 2 Bcf/d of the available regasification capacity, and we anticipate retaining a portion of regasification capacity for our own use.

Construction of Phase 1 of our Sabine Pass LNG receiving terminal commenced in March 2005, and we anticipate commencing operations at the terminal in 2008. Construction of the Corpus Christi and Creole Trail LNG receiving terminals is anticipated to commence in 2006 and 2007, respectively, and we anticipate commencing operations at the facilities in 2010 and 2011, respectively.

**Natural Gas Pipeline Development Business**

We anticipate developing natural gas pipelines from each of our three LNG receiving terminals to provide optimal access to North American natural gas markets. Development efforts to date have focused primarily on advancing our pipeline projects through the regulatory review and authorization process. Recently, our development efforts have also included the construction and operation of our proposed natural gas pipelines. We anticipate commencing construction of our Sabine Pass pipeline in early 2007 and that it will be operational in the fourth quarter of 2007.

**LNG and Natural Gas Marketing Business**

Our LNG and natural gas marketing business is in its early stages of development. Utilizing a portion of our planned LNG receiving terminal regasification capacity that we intend to reserve for use by Cheniere Marketing at our three LNG receiving terminals, we intend to purchase LNG from foreign suppliers, arrange transportation of LNG to our network of LNG receiving terminals, arrange the transportation of revaporized natural gas through our pipelines and other interconnected pipelines and sell natural gas to buyers in the North American market. In addition, we also expect to enter into domestic natural gas purchase and sale transactions as part of our marketing activities.

**Oil and Gas Exploration and Development Business**

Although our focus is primarily on the development of LNG-related businesses, we continue to be involved to a limited extent in oil and gas exploration, development and exploitation, and in exploitation of our existing 3D seismic database through prospect generation. We have historically focused on evaluating and generating



---

## **Table of Contents**

drilling prospects using a regional and integrated approach with a large seismic database as a platform. Our current oil and gas exploration and development activities are focused on the Cameron Project and the Offshore Texas Project Area. From time to time, we will invest in drilling a share of these prospects and may pursue opportunities in other geographic locations as well.

### **Liquidity and Capital Resources**

We are primarily engaged in LNG-related business activities. Our three LNG terminal projects, as well as our proposed pipelines, will require significant amounts of capital and are subject to risks and delays in completion. In addition, our marketing business will need a substantial amount of capital for hiring employees, satisfying creditworthiness requirements of contracts and developing the systems necessary to implement our business strategy. Even if successfully completed and implemented, our LNG-related business activities are not expected to begin to operate and generate significant cash flows before 2008. As a result, our business success will depend to a significant extent upon our ability to obtain the funding necessary to construct our three LNG terminals and related pipelines, to bring them into operation on a commercially viable basis and to finance the costs of staffing, operating and expanding our company during that process.

We currently estimate that the cost of completing our three LNG receiving terminals will be approximately \$3.0 billion, before financing costs. In addition, we expect that capital expenditures of approximately \$800 million to \$1 billion will be required to construct our three proposed pipelines.

As of December 31, 2005, we had working capital of \$810.1 million. While we believe that we have adequate financial resources available to us through 2006, we must augment our existing sources of cash with significant additional funds in order to carry out our long-term business plan. We currently expect that our capital requirements will be financed in part through cash on hand, issuances of project-level debt, equity or a combination of the two and in part with net proceeds of debt or equity securities issued by Cheniere or other Cheniere borrowings.

### **Our LNG Receiving Terminals**

#### ***Sabine Pass LNG***

We currently estimate that the cost of constructing Phase 1 of the Sabine Pass LNG facility will be approximately \$900 million to \$950 million, before financing costs, which will be funded as described below. Phase 2 of the Sabine Pass LNG facility may be constructed in stages. The first stage is estimated to cost approximately \$500 million to \$550 million, before financing costs. We are currently evaluating funding alternatives for the first stage of construction of Phase 2 of the Sabine Pass LNG facility, which may include existing cash balances, proceeds from debt or equity offerings, or a combination thereof. The second stage of constructing Phase 2 of the Sabine Pass LNG facility is still under evaluation.

#### ***Sabine Pass Credit Facility***

In February 2005, Sabine Pass LNG entered into the \$822 million Sabine Pass Credit Facility with an initial syndicate of 47 financial institutions. Société Générale serves as the administrative agent and HSBC serves as collateral agent. The Sabine Pass Credit Facility will be used to fund a substantial majority of the costs of constructing and placing into operation Phase 1 of the Sabine Pass LNG receiving terminal. Unless Sabine Pass LNG decides to terminate availability earlier, the Sabine Pass Credit Facility will be available until no later than April 1, 2009, after which time any unutilized portion of the Sabine Pass Credit Facility will be permanently canceled. Before Sabine Pass LNG could make an initial borrowing under the Sabine Pass Credit Facility, it was required to provide evidence that it had received equity contributions in amounts sufficient to fund \$233.7 million of the project costs. As of December 31, 2005, the \$233.7 million equity contributions had been funded and, as a result, we began drawing under the Sabine Pass Credit Facility in January 2006. As of February 28, 2006, \$58.5 million had been drawn under the Sabine Pass Credit Facility. In addition, we made a \$37.4 million subordinated loan to Sabine Pass LNG in late 2005.

---

## Table of Contents

Borrowings under the Sabine Pass Credit Facility bear interest at a variable rate equal to LIBOR plus the applicable margin. The applicable margin varies from 1.25% to 1.625% during the term of the Sabine Pass Credit Facility. The Sabine Pass Credit Facility provides for a commitment fee of 0.50% per annum on the daily committed, undrawn portion of the Sabine Pass Credit Facility. Administrative fees must also be paid annually to the agent and the collateral agent. The principal of loans made under the Sabine Pass Credit Facility must be repaid in semi-annual installments commencing six months after the later of (i) the date that substantial completion of the project occurs under the EPC agreement and (ii) the commercial start date under the Total TUA. Sabine Pass LNG may specify an earlier date to commence repayment upon satisfaction of certain conditions. In any event, payments under the Sabine Pass Credit Facility must commence no later than October 1, 2009, and all obligations under the Sabine Pass Credit Facility mature and must be fully repaid by February 25, 2015.

Under the terms and conditions of the Sabine Pass Credit Facility, all cash held by Sabine Pass LNG is controlled by the collateral agent. These funds can only be released by the collateral agent upon receipt of satisfactory documentation that the Sabine Pass LNG project costs are bona fide expenditures and are permitted under the terms of the Sabine Pass Credit Facility. The Sabine Pass Credit Facility does not permit Sabine Pass LNG to hold any cash, or cash equivalents, outside of the accounts established under the agreement. Because these cash accounts are controlled by the collateral agent, the Sabine Pass LNG cash balance of \$8.9 million held in these accounts as of December 31, 2005 is classified as restricted on our balance sheet.

The Sabine Pass Credit Facility contains customary conditions precedent to the initial borrowing and any subsequent borrowings, as well as customary affirmative and negative covenants. Sabine Pass LNG has obtained, and may in the future seek, consents, waivers and amendments to the Sabine Pass Credit Facility documents. The obligations of Sabine Pass LNG under the Sabine Pass Credit Facility are secured by all of Sabine Pass LNG's personal property, including the Total and Chevron USA TUAs and the partnership interests in Sabine Pass LNG.

In connection with the closing of the Sabine Pass Credit Facility, Sabine Pass LNG entered into swap agreements with HSBC and Société Générale. Under the terms of the swap agreements, Sabine Pass LNG will be able to hedge against rising interest rates, to a certain extent, with respect to its drawings under the Sabine Pass Credit Facility up to a maximum amount of \$700 million. The swap agreements have the effect of fixing the LIBOR component of the interest rate payable under the Sabine Pass Credit Facility with respect to hedged drawings under the Sabine Pass Credit Facility up to a maximum of \$700 million at 4.49% from July 25, 2005 to March 25, 2009 and at 4.98% from March 26, 2009 through March 25, 2012. The final termination date of the swap agreements will be March 25, 2012.

### *EPC Agreement*

Sabine Pass LNG issued an NTP in early April 2005, which required Bechtel to commence all other aspects of the work under the EPC agreement. Sabine Pass LNG agreed to pay to Bechtel a contract price of \$646.9 million plus certain reimbursable costs for the work under the EPC agreement. This contract price is subject to adjustment for changes in certain commodity prices, contingencies, change orders and other items. Payments under the EPC agreement will be made in accordance with the payment schedule set forth in the EPC agreement. The contract price and payment schedule, including milestones, may be amended only by change order. Bechtel will be liable to Sabine Pass LNG for certain delays in achieving substantial completion, minimum acceptance criteria and performance guarantees. Bechtel will be entitled to a scheduled bonus of \$12 million, or a lesser amount in certain cases, if on or before April 3, 2008, Bechtel completes construction sufficient to achieve, among other requirements specified in the EPC agreement, a sendout rate of at least 2.0 Bcf/d for a minimum sustained test period of 24 hours. Bechtel will be entitled to receive an additional bonus of \$67,000 per day (up to a maximum of \$6 million) for each day that commercial operation is achieved prior to April 1, 2008. As of February 28, 2006, change orders for \$64.8 million were approved, thereby increasing the total contract price to \$711.8 million. We anticipate additional change orders intended to mitigate ongoing effects of the 2005

---

## **Table of Contents**

hurricanes that would increase the contract price by an amount not expected to exceed \$50 million. We expect to submit any such change orders to our lenders by May 3, 2006 for approval under the Sabine Pass Credit Facility.

Bechtel has claimed events of *force majeure* arising out of three hurricanes in 2005 along the U.S. Gulf Coast. Sabine Pass LNG is currently in negotiations with Bechtel and certain subcontractors concerning additional activities and expenditures in order, among other things, to attract sufficient skilled labor to mitigate potential schedule delays and provide a reasonable opportunity for Bechtel to attain the initial target bonus date of April 3, 2008. As part of these negotiations, we have agreed in principle to defer the date by which substantial completion of the entire project is required to be accomplished under the EPC contract from September 3 to December 20, 2008. In the absence of substantial completion by such date, Bechtel would be obligated to pay us certain liquidated damages as provided under the terms of the contract. We expect that the above-described arrangement will not exceed \$50 million, although such amount is subject to change, requires approval of the lenders under our Sabine Pass Credit Facility and requires that a change order be agreed upon with Bechtel.

### *Customer TUAs*

Total has paid Sabine Pass LNG nonrefundable advance capacity reservation fees of \$20 million in the aggregate (\$10 million in each of 2004 and 2005) in connection with the reservation under a 20-year TUA (with extension options) of approximately 1.0 Bcf/d of LNG regasification capacity at the Sabine Pass LNG receiving terminal. These capacity reservation fee payments will be amortized over a 10-year period as a reduction of Total's regasification capacity fee under the TUA.

Chevron USA has paid Sabine Pass LNG nonrefundable advance capacity reservation fees of \$20 million in the aggregate (\$12 million in 2004 and \$8 million in 2005) in connection with the reservation under a 20-year TUA (with extension options) of approximately 1.0 Bcf/d of LNG regasification capacity at the Sabine Pass LNG receiving terminal, taking into account the option exercised by Chevron USA in December 2005. These capacity reservation fee payments will be amortized over a 10-year period as a reduction of Chevron USA's regasification capacity tariff under the TUA.

### *Corpus Christi LNG*

We currently estimate that the cost of constructing the Corpus Christi LNG facility will be approximately \$650 million to \$750 million, before financing costs. This estimate is based in part on our negotiations with a major international EPC contractor. Our cost estimate is subject to change due to such items as cost overruns, change orders, changes in commodity prices (particularly steel) and escalating labor costs.

BPU LNG was required to fund 100% of the first \$4.5 million of Corpus Christi LNG's expenditures, which amount was funded as of March 31, 2004. From that date until February 8, 2005, when we acquired BPU LNG's 33.3% interest, we funded 66.7% of the expenditures of Corpus Christi LNG, with BPU LNG funding the balance. Since February 8, 2005, BPU LNG has not been required to fund any expenditures, and as the sole owner of Corpus Christi LNG, we are now required to fund 100% of expenditures.

We expect to begin site preparation and detailed engineering work in the second quarter of 2006 and to commence operations at the Corpus Christi LNG receiving terminal in early 2010.

We currently expect to fund the project costs for our Corpus Christi LNG receiving terminal from cash balances, project financing similar to that used for our Sabine Pass LNG facility, proceeds from debt or equity offerings, or a combination thereof. If these types of financing are not available, we will be required to seek alternative sources of financing, which may not be available on acceptable terms, if at all.

### *Creole Trail LNG*

We currently estimate that the cost of constructing the Creole Trail LNG facility will be approximately \$850 million to \$950 million, before financing costs. Our cost estimate is preliminary and subject to change. We

---

## **Table of Contents**

currently expect to fund the costs of the Creole Trail LNG terminal project using financing similar to that used for our Sabine Pass LNG facility, proceeds from future debt or equity offerings, existing cash or a combination thereof. If these types of financing are not available, we will be required to seek alternative sources of financing, which may not be available on acceptable terms, if at all.

### **Other LNG Interests**

We have a 30% limited partner interest in Freeport LNG. Under the limited partnership agreement of Freeport LNG, development expenses of the Freeport LNG project and other Freeport LNG cash needs generally are to be funded out of Freeport LNG's own cash flows, borrowings or other sources, and, up to a pre-agreed total amount, with capital contributions by the limited partners. In July 2004, Freeport LNG entered into a credit agreement with ConocoPhillips to provide a substantial majority of the debt financing. We received capital calls, and made capital contributions, in the amount of approximately \$2.1 million in 2005. In December 2005, Freeport LNG announced that it had closed a \$383 million private placement of notes, which will be used to fund the remaining portion of the initial phase of the project, a portion of the cost of expanding the LNG receiving terminal and the development of 7.5 Bcf of underground salt cavern gas storage. As a result of such financing being obtained, we do not anticipate that any capital calls will be made upon the limited partners of Freeport LNG in the foreseeable future.

Although no capital calls are currently outstanding, and we do not anticipate any in the foreseeable future, additional capital calls may be made upon us and the other limited partners in Freeport LNG. In the event of each such future capital call, we will have the option either to contribute the requested capital or to decline to contribute. If we decline to contribute, the other limited partners could elect to make our contribution and receive back twice the amount contributed on our behalf, without interest, before any Freeport LNG cash flows are otherwise distributed to us. We currently expect to evaluate Freeport LNG capital calls on a case-by-case basis and to fund additional capital contributions that we elect to make using cash on hand and funds raised through the issuance of Cheniere equity or debt securities or other Cheniere borrowings.

### **Our Proposed Pipelines**

We estimate that approximately \$800 million to \$1 billion of total capital expenditures will be required to construct our three proposed pipelines. We currently expect to fund the costs of our three proposed pipelines from our existing cash balances, project financing, proceeds from future debt or equity offerings, or a combination thereof.

On February 21, 2006, Cheniere Sabine Pass Pipeline Company entered into an EPC pipeline contract with Willbros. Under the EPC pipeline contract, which is effective as of February 1, 2006, Willbros will provide Cheniere Sabine Pass Pipeline Company with services for the management, engineering, material procurement, construction and construction management of the Sabine Pass pipeline. Cheniere Sabine Pass Pipeline Company entered into the EPC pipeline contract sufficiently in advance of commencement of physical construction of the pipeline in order to perform detailed engineering and procure materials. This EPC pipeline contract, among other things, provides for a guaranteed maximum price of approximately \$67.7 million, subject to adjustment under certain circumstances, as provided in the contract. We estimate that the total cost to construct the pipeline, including certain work not included in the EPC pipeline contract, such as interconnection with third-party pipelines, will be approximately \$90 million. Our total cost estimate is preliminary and subject to change due to such items as cost overruns, change orders, changes in commodity prices (particularly steel) and escalation of labor costs. Construction contracts for the Corpus Christi and Creole Trail pipelines have not been negotiated.

### **Our Marketing Business**

We are in the early stages of developing our LNG and natural gas marketing business. We will need to spend funds to develop our marketing business, including capital required to satisfy any creditworthiness requirements under contracts. These costs are expected to be incurred to develop the systems necessary to implement our business strategy and to hire additional employees to conduct our natural gas marketing activities. We expect to fund these expenses with available cash balances.

---

## [Table of Contents](#)

### **Other Capital Resources**

#### ***Convertible Senior Unsecured Notes***

In July 2005, we consummated a private offering of \$325 million aggregate principal amount of Convertible Senior Unsecured Notes due August 1, 2012 to qualified institutional buyers pursuant to Rule 144A under the Securities Act. The notes bear interest at a rate of 2.25% per year. The notes are convertible into our common stock pursuant to the terms of the indenture governing the notes at an initial conversion rate of 28.2326 per \$1,000 principal amount of the notes, which is equal to a conversion price of approximately \$35.42 per share. We may redeem some or all of the notes on or before August 1, 2012, for cash equal to 100% of the principal plus any accrued and unpaid interest if in the previous 10 trading days the volume-weighted average price of our common stock exceeds \$53.13, subject to adjustment, for at least five consecutive trading days. In the event of such a redemption, we will make an additional payment equal to the present value of all remaining scheduled interest payments through August 1, 2012, discounted at the U.S. Treasury rate plus 50 basis points. The indenture governing the notes contains customary reporting requirements.

Concurrent with the issuance of the Convertible Senior Unsecured Notes, we also entered into hedge transactions in the form of an issuer call spread (consisting of a purchase and a sale of call options on our common stock) with an affiliate of the initial purchaser of the notes, having a term of two years and a net cost to us of \$75.7 million. These hedge transactions are expected to offset potential dilution from conversion of the notes up to a market price of \$70.00 per share. The net cost of the hedge transactions will be recorded as a reduction to Additional Paid-in-Capital in accordance with the guidance of EITF Issue 00-19, *Accounting for Derivative Financial Instruments Indexed to, and Potentially Settled in, a Company's Own Stock*. Net proceeds from the offering were \$239.8 million, after deducting the cost of the hedge transactions, the underwriting discount and related fees. As of December 31, 2005, no holders had elected to convert their notes.

We currently intend to use the net proceeds from the Convertible Senior Unsecured Notes offering primarily for the following purposes: (i) to fund Phase 2 of the Sabine Pass LNG receiving terminal, development and construction of the Corpus Christi and/or Creole Trail LNG receiving terminals and pipelines, (ii) to pay debt service obligations and/or (iii) for general corporate purposes.

#### ***Term Loan***

In August 2005, Cheniere LNG Holdings, LLC, or Cheniere LNG Holdings, a wholly-owned subsidiary of Cheniere, entered into a \$600 million term loan, or Term Loan, with Credit Suisse. The Term Loan interest rate equals LIBOR plus a 2.75% margin and terminates on August 30, 2012. In connection with the closing, Cheniere LNG Holdings entered into swap agreements with Credit Suisse to hedge the LIBOR interest rate component of the Term Loan. The blended rate of the swap agreements on the Term Loan results in an annual fixed interest rate of 7.25% (including the 2.75% margin) for the first five years (See Note 10 to our Consolidated Financial Statements). On December 30, 2005, Cheniere LNG Holdings made the first required quarterly principal payment of \$1.5 million. Quarterly principal payments of \$1.5 million are required through June 30, 2012, and a final principal payment of \$559.5 million is required on August 30, 2012. The Term Loan contains customary affirmative and negative covenants. The obligations of Cheniere LNG Holdings are secured by its 100% equity interest in Sabine Pass LNG and its 30% limited partner equity interest in Freeport LNG.

Under the conditions of the Term Loan, Cheniere LNG Holdings was required to fund from the loan proceeds a total of \$216.2 million into two collateral accounts. These funds are restricted and to be disbursed only for the payment of interest and principal due under the Term Loan, reimbursement of certain expenses, and funding of additional capital contributions to Sabine Pass LNG as required under the Sabine Pass Credit Facility. Because these accounts are controlled by Credit Suisse, the collateral agent, our cash and cash equivalent undisbursed balance of \$168.5 million held in these accounts as of December 31, 2005 is classified as restricted on our consolidated balance sheet. Of this amount, \$16.5 million is classified as non-current due to the timing of certain required debt amortization payments.

---

## Table of Contents

We currently intend to use the remaining proceeds from the Term Loan primarily for the following purposes: (i) to fund requirements in excess of amounts available under the Sabine Pass Credit Facility for the construction of the Sabine Pass LNG receiving terminal, (ii) to pay specified Term Loan debt service obligations and certain other expenses, (iii) to fund Phase 2 of the Sabine Pass LNG receiving terminal, (iv) to fund the development and construction of the Corpus Christi and/or Creole Trail LNG receiving terminals and pipelines and/or (v) for general corporate purposes.

### **Short-Term Liquidity Needs**

We anticipate funding our more immediate liquidity requirements, including some expenditures related to the construction of our LNG receiving terminals, the development of our pipeline business, the growth of our marketing business and our oil and gas exploration, development and exploitation activities, through a combination of any or all of the following:

- cash balances;
- drawings under the Sabine Pass Credit Facility;
- issuances of Cheniere debt and equity securities, including issuances of common stock pursuant to exercises by the holders of existing options;
- LNG receiving terminal capacity reservation fees;
- collection of receivables; and
- sales of prospects generated by our oil and gas exploration and development business.

### **Historical Cash Flows**

Net cash used in operations increased to \$18.4 million in 2005 compared to \$661,000 in 2004. This \$17.7 million increase was primarily due to continued development of our LNG receiving terminals and related pipelines and increased costs to support such activities.

Net cash used in investing activities was \$406.1 million during 2005 compared to net cash provided by investing activities of \$1.2 million in 2004. During 2005, we funded \$177.4 million related to restricted cash balances as required by the Term Loan and the Sabine Pass Credit Facility. We also advanced \$8.1 million to the Sabine Pass LNG EPC contractor (net of \$24.2 million applied against invoices and transferred to construction-in-progress related to the Sabine Pass LNG receiving terminal). We recorded \$229.7 million to construction-in-progress related to Phase 1 of the Sabine Pass LNG facility. The remaining cash used in investing activities during 2005 was used primarily for the purchase of fixed assets, advances to Freeport LNG, and oil and gas property additions. These uses were partially offset by \$20.2 million in proceeds received from the sale of our interest in Gryphon and \$1.2 million received from the sale of interests in oil and gas prospects. During 2004, cash provided by investing activities of \$1.2 million included a reimbursement from our limited partnership investment, proceeds from the sale of a limited partnership interest, and sales of our interests in oil and gas prospects, partially offset by oil and gas property and fixed asset additions.

Net cash provided by financing activities was \$808.7 million during 2005 compared to \$306.7 million in 2004. During 2005, we received proceeds from the issuance of our Convertible Senior Unsecured Notes and completion of the Term Loan in the amounts of \$249.3 million (net of \$75.7 million for the issuer call spread) and \$600 million, respectively. In addition, we received \$3.0 million in proceeds from the exercise of stock options and warrants. These proceeds were partially offset by \$42.1 million in debt issuance costs related to the Sabine Pass Credit Facility, the Convertible Senior Unsecured Notes and the Term Loan. During 2004, we received proceeds from our \$300.0 million public equity offering of common stock in December 2004 (before related offering costs of \$14.1 million). In addition, we received \$20.9 million from a private sale of our common stock (before offering costs of \$965,000) and exercises of warrants and stock options. We also received \$3.1 million in partnership contributions in 2004 made by the minority owner in Corpus Christi LNG. Cash flows from financing activities in 2004 were partially offset by the repayment of a \$1.0 million note payable.

---

## Table of Contents

Due to the factors described above, our cash and cash equivalents increased to \$692.6 million as of December 31, 2005 compared to \$308.4 million at December 31, 2004, and our working capital increased to \$810.1 million as of December 31, 2005 compared to \$305.8 million at December 31, 2004.

### **Issuances of Common Stock**

From our inception until August 2005, the primary source of financing for our operating expenses, investments in our exploration program and investments in our development of LNG receiving terminals was the sale of our equity securities. During 2005 and 2004, we raised \$3 million and \$305.9 million, respectively, net of offering costs, from the exchange or exercise of warrants, the exercise of stock options, a public equity offering of common stock and the sale of Cheniere common stock to accredited investors pursuant to Regulation D.

In February 2005, our stockholders approved an increase in Cheniere's authorized common stock from 40 million to 120 million shares. On April 22, 2005, we issued 26,789,242 shares of our common stock in a two-for-one stock split. The stock split entitled all stockholders of record at the close of business on April 8, 2005 to receive one additional share of common stock for each share held on that date. All per share amounts and outstanding and weighted share amounts included in this annual report on Form 10-K have been restated to give effect to the two-for-one stock split.

In February 2005, we acquired the 33.3% minority interest in Corpus Christi LNG through the acquisition of BPU LNG in exchange for 2 million restricted shares of our common stock valued at \$77 million plus direct transaction costs.

In December 2005, 160,151 shares were issued to employees and outside directors in the form of non-vested (restricted) stock awards related to our performance in 2005. We recorded \$6.2 million of deferred compensation as a reduction to stockholders' equity. In 2005, we also issued 15,000 shares of non-vested stock to certain employees. As a result, we recorded \$498,000 of deferred compensation as a reduction of stockholders' equity. During 2005, we recorded \$3.5 million (before capitalization of \$145,000 as oil and gas property costs) in total non-cash compensation expense related to the amortization of deferred compensation.

During 2005, a total of 864,000 shares of our common stock were issued pursuant to the exercise of stock options, resulting in net cash proceeds of \$2.5 million. A total of 433,000 shares of common stock were also issued pursuant to the exercise of warrants, resulting in net cash proceeds of \$520,000. In addition, 97,000 shares were issued in satisfaction of cashless exercises of warrants to purchase 100,000 shares of common stock, and 33,000 shares were issued in satisfaction of cashless exercises of options to purchase 34,000 shares of common stock.

We issued a total of 17.9 million shares of common stock in 2004. In January 2004, we issued 2.2 million shares of common stock in a private placement under Regulation D to twelve accredited investors for total consideration of \$14.9 million. We paid a 6.5% sales commission totaling \$965,000, resulting in \$13.9 million of net proceeds received from the offering. In February 2004, 766,000 shares were issued to employees and outside directors in the form of vested stock and non-vested stock awards related to our performance in 2003. This included 322,000 shares of stock for which we recorded \$2.4 million in non-cash compensation expense, and 444,000 shares of non-vested stock for which we recorded \$3.3 million in deferred compensation as a reduction in stockholders' equity. In November 2004, 236,000 shares were issued to employees and outside directors in the form of non-vested stock awards related to our performance in 2004. We recorded \$4.9 million of deferred compensation as a reduction to stockholders' equity. In December 2004, we issued 10 million shares of common stock in connection with a public offering, for which we received net proceeds of \$285.9 million. Throughout 2004, we issued a total of 1.8 million shares pursuant to the exercise of warrants, resulting in net cash proceeds of \$3.4 million. We also issued 2.4 million shares pursuant to the exercise of stock options, resulting in net proceeds of \$2.7 million and 553,000 shares in satisfaction of cashless exercises of stock options and warrants to purchase 390,000 and 250,000 shares, respectively.

## Table of Contents

We issued a total of 6.4 million shares of common stock in 2003. In April 2003, we issued 1.5 million shares of common stock pursuant to a contingent contractual obligation related to Cheniere's 2001 acquisition of an option to lease the Freeport LNG receiving terminal site. In May 2003, we issued 1.6 million shares of common stock to seventeen investors in a private placement made pursuant to Regulation D. The purchase price of the shares included cash of \$1.2 million and the surrender of existing warrants to purchase 1.6 million shares of our common stock. Offering expenses relating to the private placement were \$57,000. In August 2003, we issued 757,000 shares pursuant to a cashless exercise of warrants to purchase 1.4 million shares. Throughout 2003, we issued a total of 2.2 million shares pursuant to the exercise of warrants, resulting in net cash proceeds of \$2.9 million. We also issued 375,000 shares pursuant to the exercise of stock options, resulting in proceeds of \$292,000.

### Contractual Obligations

We are committed to making cash payments in the future on certain of our contracts. We have no off-balance sheet debt or other such unrecorded obligations, and we have not guaranteed the debt of any other party. Below is a schedule of the future payments that we are obligated to make based on agreements in place as of December 31, 2005 (in thousands).

	Payments Due for Years Ending December 31,				
	Total	2006	2007- 2008	2009- 2010	Thereafter
Term Loan (1)	\$ 598,500	\$ 6,000	\$ 12,000	\$ 12,000	\$ 568,500
Convertible Senior Unsecured Notes (1)	325,000	—	—	—	325,000
Operating Leases (2)	50,486	2,024	4,903	4,861	38,698
Other Obligations (3)	692	496	166	30	—
<b>Total</b>	<b>\$ 974,678</b>	<b>\$ 8,520</b>	<b>\$ 17,069</b>	<b>\$ 16,891</b>	<b>\$ 932,198</b>

- (1) A discussion of these obligations can be found at Note 14 to our Consolidated Financial Statements.
- (2) A discussion of these obligations can be found at Note 21 to our Consolidated Financial Statements.
- (3) Includes obligations for telecommunication services and software licensing.

### Lease Commitments and Other Obligations

We currently have lease commitments for approximately 56,000 square feet of office space in downtown Houston, Texas. In October 2003, we entered into a lease agreement for office space having a term which runs from December 2003 through April 2014. Beginning in April 2004, our monthly lease rental for this space is \$21,000 and escalates to \$24,000 beginning in February 2009 through the remaining term of the lease. We have an option to renew the lease for an additional five years at the then-current market rate. In May 2004, we amended our office lease agreement to increase our rentable square footage (the "Expansion Space"). The lease term for the Expansion Space runs from September 2004 through August 2009. Our monthly lease rental for the Expansion Space is \$14,000 beginning in June 2005. We have the option, subject and subordinate to another tenants' renewal option, to renew the lease for an additional five years. In March 2005, we further amended our office lease to increase our rentable square footage to include an additional floor on the premises. The lease term for the additional floor runs from May 2005 through January 2014. We have an option to renew the lease for an additional five years at the then-current market rate as part of the renewal of our original lease space. Under the amended lease, there are no monthly lease payments for the additional floor from May 2005 through April 2007, after which time the lease payments range from approximately \$30,000 to \$39,000 per month through January 2014. We have prepaid \$201,000 in rent related to 2013 and have included such amount in Other Assets on the consolidated balance sheet as of December 31, 2005.

Our obligations under LNG site options are renewable on an annual or semiannual basis. We may terminate our obligations at any time by electing not to renew or by exercising the options.



---

## **Table of Contents**

In January 2005, we exercised our options and entered into three land leases for our Sabine Pass LNG receiving terminal site. The leases have an initial term of 30 years, with options to renew for six 10-year extensions. In February 2005, two of the three leases were amended, thereby increasing the total acreage under lease to 853 acres and increasing the annual lease payments to \$1.5 million. For 2005, these payments have been capitalized as part of the construction cost of the Sabine Pass LNG receiving terminal; however, beginning in January 2006, these lease payments have been expensed as required by Financial Accounting Standards Board, or FASB, Staff Position, or FSP, 13-1, *Accounting for Rental Costs Incurred During Construction*.

### **Restricted Certificate of Deposit and Letter of Credit**

Under the terms of our office lease, we are required to post a standby letter of credit in favor of the lessor. The initial amount of the letter of credit was increased from \$865,000 to \$1.1 million in April 2004 related to the expansion of our office space; and the amount will be reduced by approximately \$225,000 per annum over a five-year period. This letter of credit was initially established under the terms of our bank line of credit at that time.

Upon the termination of our bank line of credit in June 2004, we purchased a certificate of deposit in the amount of \$1.1 million and entered into a pledge agreement in favor of the commercial bank that had previously issued the standby letter of credit for \$1.1 million. In October 2004 and 2005, both the letter of credit and certificate of deposit were amended to decrease the face amounts by approximately \$225,000 to \$898,000 and \$674,000, respectively. The renewed letter of credit and the certificate of deposit both mature on November 30, 2005. Under the terms of the pledge agreement, the commercial bank was assigned a security interest in the certificate of deposit as collateral for the letter of credit. As a result, the certificate of deposit plus \$2,000 of accrued interest is classified as restricted on our balance sheet at December 31, 2005.

### **Off-Balance Sheet Arrangements**

As of December 31, 2005, we had no “off-balance sheet arrangements” that may have a current or future material affect on our consolidated financial position or results of operations.

### **Inflation**

During 2003, 2004 and 2005, inflation and changing commodity prices have had an impact on our revenues but have not significantly impacted our results of operations. However, we have experienced escalated steel prices relating to the construction of our LNG receiving terminals and labor costs in connection with the collateral effects of the 2005 hurricanes.

### **Prior Bank Line of Credit**

In June 2004, we terminated our \$5 million line of credit with a commercial bank. This facility was originally established in July 2003 with a borrowing base of \$2 million. During 2003, we borrowed \$1 million under the facility to acquire oil and gas leases, which we subsequently repaid in January 2004.

### **Short-Term Promissory Notes**

In February 2003, we executed a promissory note payable in the amount of \$225,000. The proceeds of the note were used to pay certain costs related to our 3-D seismic database. In July 2003, we repaid the note payable.

### **Results of Operations—Comparison of the Fiscal Years Ended December 31, 2005 and 2004**

*Overview*—Our financial results for the year ended December 31, 2005 reflect a net loss of \$29.8 million, or \$0.56 per share (basic and diluted), compared to a net loss of \$24.6 million, or \$0.63 per share (basic and diluted), in 2004.

The major factors contributing to our net loss of \$29.8 million in 2005 were LNG receiving terminal development expenses of \$22.0 million and general and administrative expenses of \$29.1 million, which were

---

## Table of Contents

significantly offset by the \$20.2 million gain on the sale of our investment in Gryphon. Absent the gain on the sale of our investment in Gryphon, we would have reported a net loss of \$50.0 million, or \$0.94 per share (basic and diluted), for 2005. The major factors contributing to our \$24.6 million net loss in 2004 were LNG receiving terminal development expenses of \$17.2 million and general and administrative expenses of \$12.5 million, which were partially offset by a \$2.9 million minority interest in the operations of Corpus Christi LNG and by a \$2.5 million reimbursement from our limited partner investment in Freeport LNG.

*LNG Receiving Terminal Development and Related Pipeline Activities*—LNG receiving terminal development expenses increased \$4.8 million, or 28%, to \$22.0 million in 2005 compared to \$17.2 million in 2004. Our development expenses primarily included professional fees associated with front-end engineering and design work, obtaining orders from FERC authorizing construction of our facilities and other required permitting for our planned LNG receiving terminals, their related natural gas pipelines as well as other initiatives that complement the development of our LNG receiving terminal business. Expenses of our LNG employees involved in development activities are also included. Beginning in the first quarter of 2005, costs related to the construction of Phase 1 of our Sabine Pass LNG receiving terminal have been capitalized.

LNG receiving terminal development expenses for 2005 totaled \$7.1 million and were mainly attributable to our Creole Trail LNG and Corpus Christi LNG terminal projects and Phase 2 of the Sabine Pass LNG project. In 2005, we incurred \$6.4 million in LNG pipeline development expenses primarily related to our Sabine Pass LNG and Creole Trail LNG projects. In addition, we incurred \$8.5 million in other LNG receiving terminal development expenses, including \$7.3 million in LNG employee-related costs. Our LNG staff increased from an average of 14 employees in 2004 to an average of 25 employees in 2005 as a result of the expansion of our business. LNG employee-related costs for 2005 included cash bonus costs of \$1.7 million related to 2005 company performance and non-cash compensation of \$1.2 million related to the amortization of deferred compensation associated with non-vested stock.

In 2004, we recorded \$5.8 million in terminal development expenses related to the Corpus Christi LNG receiving terminal. This amount was partially offset by \$2.9 million related to the minority interest of our 33.3% limited partner. Substantially all expenditures incurred through March 31, 2004 were the obligation of the minority owner, as the minority owner was required to fund 100% of the first \$4.5 million of project expenditures. As project expenditures had reached \$4.5 million by March 31, 2004, the minority owner began sharing all subsequent project expenditures based on its 33.3% limited partner interest. During 2004, we also incurred direct receiving terminal development expenses of \$6.4 million related to Phase 1 of our Sabine Pass LNG receiving terminal and \$375,000 related to our Creole Trail LNG receiving terminal, in each of which we own 100% of the projects. In addition, during 2004, we incurred \$4.8 million in LNG employee-related costs. LNG employee-related costs for 2004 also included cash bonuses of \$2.0 million and non-cash compensation of \$928,000 (which included stock awards and amortization of deferred compensation associated with non-vested stock awards).

In 2005, our 30% equity share of the net loss of Freeport LNG resulted in a reported net loss of \$1 million. In contrast, in 2004, our 30% equity share of the net loss of Freeport LNG was \$1.3 million, including \$278,000 of loss that was suspended as of December 31, 2003 (see Note 8 to our Consolidated Financial Statements).

In January 2004, we received the final \$2.5 million payment from Freeport LNG pursuant to the terms of the agreement related to our February 2003 disposition of LNG assets in exchange for cash and a limited partner interest in Freeport LNG. Because our investment basis in Freeport LNG had been previously reduced to zero, the \$2.5 million payment was recorded as a reimbursement from limited partnership investment in our consolidated statement of operations during the first quarter of 2004.

*General and Administrative Expenses*—General and administrative, or G&A, expenses increased \$16.7 million, or 134%, to \$29.1 million in 2005 compared to \$12.5 million in 2004. The increase in G&A resulted primarily from the expansion of our business (including increases in corporate staff from an average of 14

## [Table of Contents](#)

employees in 2004 to an average of 47 employees in 2005). Corporate employee-related costs for 2005 included cash bonuses of \$4.3 million and non-cash compensation of \$2.2 million related to the amortization of deferred compensation associated with non-vested stock awards. Corporate employee-related costs for 2004 included cash bonuses of \$2.2 million and non-cash compensation of \$2.7 million (which included stock awards and amortization of deferred compensation associated with non-vested stock awards). We capitalize as oil and gas property costs that portion of G&A expenses directly related to our exploration and development activities. We capitalized \$927,000 in 2005 compared to \$1.6 million in 2004.

*Depreciation, Depletion and Amortization Expenses*—Depreciation, Depletion and Amortization, or DD&A, expenses increased \$2.4 million, or 180%, to \$3.7 million in 2005 from \$1.3 million in 2004. The increase included \$1.6 million in higher oil and gas DD&A as a result of an increase in our DD&A rate from \$2.48 per Mcfe to \$5.90 per Mcfe and the higher production volumes discussed below. Other DD&A also increased by \$797,000 primarily as a result of higher depreciation expense associated with the acquisition of furniture, fixtures and equipment and office space leasehold improvements associated with the expansion of our business.

*Derivative gain, net*—During 2005, we recorded a net derivative gain of \$837,000 attributable to the ineffective portion of our interest rate swaps.

*Interest Expense*—Interest expense, net of capitalization, was \$17.4 million in 2005 compared to zero in 2004. This increase was attributable to the issuance of our Convertible Senior Unsecured Notes and completion of the Term Loan during the third quarter of 2005. Capitalized interest of \$6.1 million in 2005 was primarily related to the amortization of debt issuance cost and commitment fees associated with the Sabine Pass Credit Facility.

*Interest Income*—Interest income increased to \$17.5 million in 2005 from \$501,000 in 2004 as a result of an increase in our cash and cash equivalent balances attributable primarily to our common stock offering in December 2004 and the issuance of our Convertible Senior Unsecured Notes and completion of the Term Loan in the third quarter of 2005.

*Gain on Sale of Investment in Unconsolidated Affiliate*—On August 31, 2005, Gryphon was sold for \$283 million, plus assumption of \$14 million of net debt in a merger with Woodside Energy (USA). We received net cash proceeds of \$20.2 million for our interest, and since our investment balance was zero, we recognized a gain in 2005 equal to the net cash proceeds amount.

*Oil and Gas Activities*—Oil and gas revenues increased by \$1.0 million, or 50%, to \$3.0 million in 2005 from \$2.0 million in 2004 as a result of a 22% increase in production volumes (409,000 Mcfe in 2005 compared with 337,000 Mcfe in 2004) and a 24% increase in average natural gas prices to \$7.34 per Mcf in 2005 from \$5.93 per Mcf in 2004. We produced from an average of 10 wells in both 2005 and 2004. Oil and gas production costs increased 102% to \$237,000 in 2005 compared to \$117,000 in 2004. This increase was primarily due to higher production taxes attributable to the higher production volumes and commodity prices during 2005.

*Income Tax Benefit*—A tax benefit of \$2.0 million was recognized in 2005 relating to the portion of the change in our tax asset valuation account that is allocable to the deferred income tax on items reported in other comprehensive income on derivative instruments in accordance with Statement of Financial Accounting Standards, or SFAS, No. 109, *Accounting for Income Taxes*, and EITF *Abstracts*, Topic D-32.

### **Results of Operations—Comparison of the Fiscal Years Ended December 31, 2004 and 2003**

*Overview*—Our financial results for the year ended December 31, 2004 reflected a net loss of \$24.6 million, or \$0.63 per share (basic and diluted), compared to a net loss of \$5.3 million, or \$0.18 per share (basic and diluted), in 2003.

The major factors contributing to our net loss during 2004 were: LNG receiving terminal development expenses of \$17.2 million (which were partially offset by a \$2.9 million minority interest in the operations of

---

## Table of Contents

Corpus Christi LNG) and general and administrative expenses of \$12.5 million. These factors were partially offset by a \$2.5 million reimbursement from our limited partnership investment in Freeport LNG.

*LNG Receiving Terminal Development and Related Pipeline Activities*—LNG receiving terminal development expenses were 156% higher in 2004 (\$17.2 million) than in 2003 (\$6.7 million). Because we have been in the preliminary stage of developing our LNG receiving terminals through December 31, 2004, substantially all of the costs to such date related to such activities were expensed. These costs primarily included professional fees associated with front-end engineering and design work, obtaining an order from FERC authorizing construction of our terminals and other required permitting for Phase 1 of the Sabine Pass LNG, Corpus Christi LNG and Creole Trail LNG receiving terminals and their related natural gas pipelines. The expenses of our LNG employees directly involved in the development of our LNG receiving terminals are also included. LNG receiving terminal development expenses were significantly higher in 2004 because we accelerated, beginning in the third quarter of 2003, the schedule of LNG receiving terminal development for Phase 1 of our Sabine Pass LNG receiving terminal as well as our Corpus Christi LNG receiving terminal. We accelerated the development of our Creole Trail LNG receiving terminal in the fourth quarter of 2004.

In 2004, we recorded \$5.8 million in terminal development expenses related to the Corpus Christi LNG receiving terminal. This amount was partially offset by \$2.9 million related to the minority interest of our 33.3% limited partner. Substantially all expenditures incurred through March 31, 2004 were the obligation of the minority owner, as the minority owner was required to fund 100% of the first \$4.5 million of project expenditures. As project expenditures had reached \$4.5 million by March 31, 2004, the minority owner began sharing all subsequent project expenditures based on its 33.3% limited partner interest. Also during 2004, we incurred direct receiving terminal development expenses of \$6.4 million related to Phase 1 of our Sabine Pass LNG receiving terminal and \$375,000 related to our Creole Trail LNG receiving terminal, in each of which we own 100% of the projects. In addition, during 2004, we incurred \$4.8 million in LNG employee-related costs. In connection with the expansion of our LNG receiving terminal business, our employee costs increased, as we expanded our LNG staff from four employees during 2003 to an average of 15 employees during 2004. LNG employee-related costs for 2004 also included cash bonuses of \$2 million and non-cash compensation of \$928,000 (which included stock and non-vested stock awards) related to our 2003 and 2004 company performance.

In 2003, we incurred \$6.7 million in LNG receiving terminal development expenses. Of this amount, \$3 million related to development costs for the Corpus Christi LNG project. However, these costs were entirely offset by the minority interest of our 33.3% limited partner as discussed above. Also during 2003, we incurred \$3.7 million primarily for development expenses related to Phase 1 of our Sabine Pass LNG project and LNG employee-related costs.

In February 2003, our Freeport LNG receiving terminal project was acquired by Freeport LNG, from whom we retained a 40% limited partnership interest and received payments totaling \$5 million over time. In connection with the sale of LNG assets to Freeport LNG, we reported a gain of \$4.8 million. We also sold a 10% interest in Freeport LNG in March 2003 for \$2.3 million, resulting in a gain of \$423,000. During 2003, we received payments totaling \$2.5 million from Freeport LNG, plus \$1.7 million in reimbursement of project costs, which were recorded as a reduction to our investment in the partnership. In addition, during 2003 we recorded our equity share (\$4.5 million) related to the 2003 loss incurred by Freeport LNG, which reduced our investment basis to zero as of December 31, 2003. In January 2004, we received the final \$2.5 million payment from Freeport LNG. Because our investment basis in Freeport LNG had been reduced to zero, the payment was recorded as a reimbursement from limited partnership investment in our consolidated statement of operations for 2004.

In 2004, our 30% equity share of the net loss from Freeport LNG was \$1.3 million, including \$278,000 of loss that was suspended as of December 31, 2003 (see Note 8 to our Consolidated Financial Statements). This compares to our equity share of the loss of \$4.5 million for 2003. The significant improvement between periods for Freeport LNG was a result of Freeport LNG's receipt of a non-refundable fee of \$10 million from ConocoPhillips in January 2004.

---

## **Table of Contents**

*General and Administrative Expenses*—G&A expenses increased \$9.9 million, or 391%, to \$12.5 million in 2004 compared to \$2.5 million in 2003. The increase in G&A resulted primarily from the expansion of our business (including increases in average corporate staff from an average of 5 employees in 2003 to an average of 16 employees in 2004). Corporate employee-related costs for 2004 also included cash bonuses of \$2.2 million and non-cash compensation of \$2.7 million (which included stock and non-vested stock awards) related to our 2003 and 2004 company performance. We capitalize as oil and gas property costs that portion of G&A expenses directly related to our exploration and development activities. We capitalized \$1.6 million in 2004 compared to \$976,000 in 2003.

*Depreciation, Depletion and Amortization Expenses*—DD&A expenses increased \$895,000, or 209%, to \$1.3 million in 2004 from \$429,000 in 2003. The increase primarily resulted from higher oil and gas DD&A as a result of an increase in our DD&A rate from \$0.98 per Mcfe to \$2.48 per Mcfe and higher production volumes discussed below. DD&A also increased as a result of more depreciation expense resulting from the acquisition of furniture, fixtures and equipment associated with the expansion of our business.

*Interest Income*—Interest income increased to \$501,000 in 2004 from \$3,000 in 2003 primarily because of an increase in our cash balance resulting from our \$300 million public equity offering of our common stock in December 2004 (before related offering costs of \$14.1 million). In addition, we received \$22 million in advance regasification capacity payments in November and December of 2004 and raised \$20 million in net cash proceeds related to a private placement of our common stock and exercises of options and warrants to purchase our common stock during 2004.

*Oil and Gas Activities*—Oil and gas revenues increased by \$1.3 million, or 204%, to \$2 million in 2004 from \$658,000 in 2003 as a result of a 173% increase in production volumes (336,849 Mcfe in 2004 compared with 123,494 Mcfe in 2003) and an 11% increase in average natural gas prices to \$5.93 per Mcf in 2004 from \$5.33 per Mcf in 2003. We produced from an average of 10 wells in 2004 as compared with an average of 7 wells in 2003. We incurred little or no production cost in 2003 and 2004 because all of our revenues were generated from non-cost bearing overriding royalty interests, or ORRI, until December 2004. The small amount of production costs in 2004 is attributable to our share of production taxes on two producing wells located in Texas state waters and operating costs attributable to a well converted from an ORRI to a working interest at payout in December 2004.

### **Other Matters**

#### **Critical Accounting Estimates and Policies**

The selection and application of accounting policies is an important process that has developed as our business activities have evolved and as the accounting rules have developed. Accounting rules generally do not involve a selection among alternatives, but involve an implementation and interpretation of existing rules, and the use of judgment, to the specific set of circumstances existing in our business. We make every effort to properly comply with all applicable rules on or before their adoption, and believe the proper implementation and consistent application of the accounting rules are critical. However, not all situations are specifically addressed in the accounting literature. In these cases, we must use our best judgment to adopt a policy for accounting for these situations. We accomplish this by analogizing to similar situations and the accounting guidance governing them.

#### **Accounting for LNG Activities**

We begin capitalizing the costs of our LNG receiving terminals and related pipelines once the individual project meets the following criteria: (i) regulatory approval has been received, (ii) financing for the project is available and (iii) management has committed to commence construction. Prior to meeting these criteria, most of the costs associated with a project are expensed as incurred. These costs primarily include professional fees associated with front-end engineering and design work, costs of securing necessary regulatory approvals, and other preliminary investigation and development activities related to our LNG receiving terminals and related natural gas pipelines.

---

## **Table of Contents**

Costs that are capitalized prior to a project meeting the criteria otherwise necessary for capitalization include: land costs, costs of lease options and the cost of certain permits which are capitalized as intangible LNG assets. The costs of lease options are amortized over the life of the lease once it is obtained. If no lease is obtained, the costs are expensed. Site rental costs and related amortization of capitalized options have been capitalized during the construction period through the end of 2005. Beginning in 2006, such costs will be expensed as required by FSP 13-1.

During the construction periods of our LNG receiving terminals and related pipelines, we capitalize interest and other related debt costs in accordance with the FASB SFAS No. 34, *Capitalization of Interest Cost*, as amended by SFAS No. 58, *Capitalization of Interest Cost in Financial Statements That Include Investments Accounted for by the Equity Method (an Amendment of FASB Statement No. 34)*. Upon commencement of operations, capitalized interest, as a component of the total cost, will be amortized over the estimated useful life of the asset.

### ***Revenue Recognition***

LNG regasification capacity fees are recognized as revenue over the term of the respective TUAs. Advance capacity reservation fees are initially deferred.

### ***Full Cost Method of Accounting***

We follow the full cost method of accounting for our oil and gas properties. Under this method, all productive and non-productive exploration and development costs incurred for the purpose of finding oil and gas reserves are capitalized. Such capitalized costs include lease acquisition, geological and geophysical work, delay rentals, drilling, completing and equipping oil and gas wells, together with internal costs directly attributable to property acquisition, exploration and development activities.

The costs of our oil and gas properties, including the estimated future costs to develop proved reserves and the carrying amounts of any asset retirement obligations, are depreciated using a composite unit-of-production rate based on estimates of proved reserves. Investments in unproved properties and major development projects are not amortized until proved reserves associated with the projects can be determined or until impairment occurs. If the results of an assessment indicate that the properties are impaired, then the amount of the impairment is added to the capitalized costs to be amortized. Net capitalized costs are limited to a capitalization ceiling, calculated on a quarterly basis as the aggregate of the present value, discounted at 10%, of estimated future net revenues from proved reserves (based on current economic and operating conditions), but excluding asset retirement obligations, plus the lower of cost or fair market value of unproved properties, less related income tax effects.

Our allocation of seismic exploration costs between proved and unproved properties involves an estimate of the total reserves to be discovered through our exploration program. This estimate includes a number of assumptions that we have incorporated into a three-year plan. Such factors include an estimate of the number of exploration prospects generated, prospect reserve potential, success ratios and ownership interests. We transfer unproved properties to proved properties based on a ratio of proved reserves discovered at a point in time to the estimate of total reserves to be discovered in our exploration program. The carrying value of unproved properties is evaluated for possible impairment by comparing it to the estimated future net cash flows associated with the estimated total reserves to be discovered in our exploration program. To the extent that the carrying value of unproved properties is greater than the estimated future net revenue, any excess is transferred to proved properties. It is reasonably possible, based on the results obtained from future drilling and prospect generation, that revisions to this estimate of total reserves to be discovered could affect our capitalization ceiling.

Sales of proved and unproved properties are accounted for as adjustments of capitalized costs with no gain or loss recognized, unless such adjustments would significantly alter the relationship between capitalized costs and proved oil and gas reserves.

---

## **Table of Contents**

We account for the retirement of our tangible long-lived assets in accordance with SFAS No. 143, *Accounting for Asset Retirement Obligations*. SFAS No. 143 requires us to record the fair value of a liability for legal obligations associated with the retirement of tangible long-lived assets and a corresponding increase in the carrying amount of the related long-lived assets. Subsequently, the asset retirement costs included in the carrying amount of the related asset are allocated to expense using the unit-of-production method used to depreciate oil and gas properties under the full cost method of accounting.

### ***Oil and Gas Reserves***

The process of estimating quantities of proved reserves is inherently uncertain, and our reserve data are only estimates. Reserve engineering is a subjective process of estimating underground accumulations of natural gas and crude oil that cannot be measured in an exact manner. The process relies on interpretations of available geologic, geophysical, engineering and production data. The extent, quality and reliability of this technical data can vary. The process also requires certain economic assumptions, some of which are mandated by the SEC, such as oil and gas prices, drilling and operating expenses, capital expenditures, taxes and availability of funds. The accuracy of a reserve estimate is a function of the quality and quantity of available data, the interpretation of that data, the accuracy of various mandated economic assumptions and the judgment of the persons preparing the estimate. At least annually, our reserves are estimated by an independent petroleum engineer.

Because these estimates depend on many assumptions, all of which may substantially differ from actual results, reserve estimates may be different from the quantities of natural gas and crude oil that are ultimately recovered. In addition, results of drilling, testing and production after the date of an estimate may justify material revisions to the estimate.

The present value of future net cash flows does not necessarily represent the current market value of our estimated proved natural gas and oil reserves. In accordance with SEC requirements, we base the estimated discounted future net cash flows from proved reserves on prices and costs on the date of the estimate. Actual future prices and costs may be materially higher or lower than the prices and costs as of the date of the estimate.

Our rate of recording DD&A is dependent upon our estimate of proved reserves. If the estimate of proved reserves declines, the rate at which we record DD&A expense increases thereby reducing net income. Such a decline may result from lower market prices, which may make it uneconomical to drill for and produce higher cost fields.

### ***Cash Flow Hedges***

As defined in SFAS No. 133, *Accounting for Derivative Instruments and Hedging Activities*, cash flow hedge transactions hedge the exposure to variability in expected future cash flows (i.e., in our case, the variability of floating interest rate exposure). In the case of cash flow hedges, the hedged item (the underlying risk) is generally unrecognized (i.e., not recorded on the balance sheet prior to settlement), and any changes in the fair value, therefore, will not be recorded within earnings. Conceptually, if a cash flow hedge is effective, this means that a variable, such as a movement in interest rates, has been effectively fixed so that any fluctuations will have no net result on either cash flows or earnings. Therefore, if the changes in fair value of the hedged item are not recorded in earnings, then the changes in fair value of the hedging instrument (the derivative) must also be excluded from the income statement or else a one-sided net impact on earnings will be reported, despite the fact that the establishment of the effective hedge results in no net economic impact. To prevent such a scenario from occurring, SFAS No. 133 requires that the fair value of a derivative instrument designated as a cash flow hedge be recorded as an asset or liability on the balance sheet, but with the offset reported as part of other comprehensive income, to the extent that the hedge is effective. Any ineffective portion will be reflected in earnings.

---

## Table of Contents

### **Goodwill**

Goodwill is accounted for in accordance with SFAS No. 142, *Goodwill and Other Intangible Assets*. We perform an annual goodwill impairment review in the fourth quarter of each year, although we may perform a goodwill impairment review more frequently whenever events or circumstances indicate that the carrying value may not be recoverable. See Note 9 to our Consolidated Financial Statements.

### **New Accounting Pronouncements**

In December 2004, the FASB issued SFAS No. 123R, *Share-Based Payment*, that addresses the accounting for share-based payment transactions in which a company receives employee services in exchange for equity instruments of the company, such as stock options and non-vested stock. SFAS No. 123R eliminates the ability to account for share-based compensation transactions using APB Opinion No. 25 and requires instead that such transactions be accounted for using a fair value-based method. From inception through December 31, 2005, we have accounted for stock-based compensation using the intrinsic value method pursuant to APB Opinion No. 25. SFAS No. 123R requires that all stock-based payments to employees, including grants of employee stock options and non-vested stock, be recognized as compensation expense in the financial statements based on their fair values (intrinsic value in the case of non-vested stock) at the time such awards are granted. SFAS No. 123R is effective January 1, 2006 for companies with fiscal years ending December 31. Accordingly, we will begin reporting the results of SFAS No. 123R on our operations in the quarter ending March 31, 2006. We are adopting the new standard using the modified-prospective transition method. The adoption of the new standard will have a significant future impact on our results of operations, but will have no impact on our cash flows. Had we adopted SFAS No. 123R in prior periods, the effects of that standard on net income and earnings per share would have been approximately the same as the effects of SFAS No. 123 presented in the Stock-Based Compensation pro forma disclosure included in Note 2 of our Consolidated Financial Statements.

In May 2005, the FASB issued SFAS No. 154, *Accounting Changes and Error Corrections—A Replacement of APB Opinion No. 20 and FASB Statement No. 3*. SFAS No. 154 changes the requirements for accounting and reporting on a change in accounting principle, while carrying forward the guidance in APB Opinion No. 20, *Accounting Changes* and FASB Statement No. 3, *Reporting Accounting Changes in Interim Financial Statements*, with respect to accounting for changes in estimates, changes in the reporting entity and the correction of errors. APB Opinion No. 20 previously required that most voluntary changes in accounting principle be recognized by including in net income of the period of the change, the cumulative effect of changing to the new accounting principle. SFAS No. 154 requires retrospective application to prior periods' financial statements for voluntary changes in accounting principle, unless it is impracticable to determine either the period-specific effects or the cumulative effect of the change. SFAS No. 154 is effective for accounting changes and corrections of errors made in fiscal years beginning after December 15, 2005. The impact of SFAS No. 154 will depend on the accounting change that may occur in a future period.

In October 2005, the FASB issued FSP 13-1 to address the accounting for rental costs associated with operating leases that are incurred during a construction period. FSP 13-1 requires rental costs associated with ground or building operating leases that are incurred during a construction period to be recognized as rental expense. FSP 13-1 is effective in fiscal years beginning after December 15, 2005. Accordingly, we will adopt the new standard in the quarter ending March 31, 2006. As of December 31, 2005, we have capitalized \$1.5 million in rental expenses related to our Sabine Pass LNG terminal site lease.

### **ITEM 7A. QUANTITATIVE AND QUALITATIVE DISCLOSURES ABOUT MARKET RISK**

The development of our LNG receiving terminal business is based upon the foundational premise that prices of natural gas in the U.S. will be sustained at levels of \$3.00 per Mcf or more. Should the price of natural gas in the U.S. decline to sustained levels below \$3.00 per Mcf, our ability to develop and operate LNG receiving terminals could be significantly negatively affected.



## [Table of Contents](#)

We produce and sell natural gas, crude oil and condensate. As a result, our financial results can be affected as these commodity prices fluctuate widely in response to changing market forces. We have not entered into any derivative transactions related to our oil and gas producing activities.

We have cash investments that we manage based on internal investment guidelines that emphasize liquidity and preservation of capital. Such cash investments are stated at historical cost, which approximates fair market value on our consolidated balance sheet.

### Interest Rates

We are exposed to changes in interest rates, primarily as a result of our debt obligations. The fair value of our fixed rate debt is affected by changes in market rates. We utilize interest rate swap agreements to mitigate exposure to rising interest rates. We do not use interest rate swap agreements for speculative or trading purposes.

In connection with the closing of the Sabine Pass Credit Facility in February 2005, we entered into interest rate swap agreements to hedge against increases in floating interest rates with respect to draws, up to a maximum of \$700 million under this facility. No debt was outstanding under this facility at December 31, 2005.

At December 31, 2005, we had \$923.5 million of debt outstanding. Of this amount, our \$325 million of Convertible Senior Unsecured Notes bore a fixed interest rate of 2.25%. The Term Loan, totaling \$598.5 million, bore interest at floating rates; however, concurrent with the closing of the Term Loan, we entered into interest rate swaps with respect to this loan. (See Note 10 to our Consolidated Financial Statements)

The following table summarizes the fair market values of our existing interest rate swap agreements as of December 31, 2005 (in thousands):

#### *Variable to Fixed Swaps*

<u>Maturity Date</u>	<u>Notional Principal Amount</u>	<u>Fixed Interest Rate (Pay)</u>	<u>Weighted Average Interest Rate</u>	<u>Fair Market Value (1)</u>
January through December 2006	\$ 4,958,050	3.75% - 4.49%	US \$ LIBOR BBA	\$ 5,841
January through December 2007	9,086,074	3.75% - 4.49%	US \$ LIBOR BBA	7,033
January through December 2008	10,638,516	3.98% - 4.49%	US \$ LIBOR BBA	2,724
January through December 2009	5,113,000	4.49% - 5.98%	US \$ LIBOR BBA	(5,382)
January through December 2010	2,942,260	4.98% - 5.98%	US \$ LIBOR BBA	(3,600)
January through December 2011	1,331,700	4.98%	US \$ LIBOR BBA	(619)
January through December 2012	650,100	4.98%	US \$ LIBOR BBA	(373)
	<u>\$ 34,719,700</u>			<u>\$ 5,624</u>

(1) The fair market value is based upon a marked-to-market calculation utilizing an extrapolation of third-party mid-market LIBOR rate quotes at December 30, 2005.

---

[Table of Contents](#)

ITEM 8. *FINANCIAL STATEMENTS AND SUPPLEMENTARY DATA*

INDEX TO FINANCIAL STATEMENTS  
CHENIERE ENERGY, INC. AND SUBSIDIARIES

<a href="#">Management's Reports to the Stockholders of Cheniere Energy, Inc.</a>	73
<a href="#">Reports of Independent Registered Public Accounting Firm</a>	74
<a href="#">Consolidated Balance Sheet</a>	76
<a href="#">Consolidated Statement of Operations</a>	77
<a href="#">Consolidated Statement of Stockholders' Equity</a>	78
<a href="#">Consolidated Statement of Cash Flows</a>	79
<a href="#">Notes to Consolidated Financial Statements</a>	80
<a href="#">Supplemental Information to Consolidated Financial Statements—Oil and Gas Reserves and Related Financial Data</a>	111
<a href="#">Supplemental Information to Consolidated Financial Statements—Summarized Quarterly Financial Data</a>	115

**MANAGEMENT'S REPORTS TO THE STOCKHOLDERS OF CHENIERE ENERGY, INC.**

**Management's Report on Internal Control Over Financial Reporting**

As management, we are responsible for establishing and maintaining adequate internal control over financial reporting for Cheniere Energy, Inc. and its subsidiaries, or Cheniere. In order to evaluate the effectiveness of internal control over financial reporting, as required by Section 404 of the Sarbanes-Oxley Act of 2002, we have conducted an assessment, including testing using the criteria in *Internal Control—Integrated Framework* issued by the Committee of Sponsoring Organizations of the Treadway Commission (COSO). Cheniere's system of internal control over financial reporting is designed to provide reasonable assurance regarding the reliability of financial reporting and the preparation of financial statements for external purposes in accordance with accounting principles generally accepted in the United States of America. Because of its inherent limitations, internal control over financial reporting may not prevent or detect misstatements.

Based on our assessment, we have concluded that Cheniere maintained effective internal control over financial reporting as of December 31, 2005, based on criteria in *Internal Control—Integrated Framework* issued by the COSO. Our assessment of the effectiveness of Cheniere's internal control over financial reporting as of December 31, 2005, has been audited by UHY Mann Frankfort Stein & Lipp CPAs, LLP, an independent registered public accounting firm, as stated in their report which is included herein.

**Management's Certifications**

The certifications of Cheniere's Chief Executive Officer and Chief Financial Officer required by the Sarbanes-Oxley Act of 2002 have been included as Exhibits 31 and 32 in Cheniere's Form 10-K.

CHENIERE ENERGY, INC.

/s/ CHARIF SOUKI

/s/ DON A. TURKLESON

By: \_\_\_\_\_

By: \_\_\_\_\_

Charif Souki  
Chief Executive Officer

Don A. Turkleson  
Senior Vice President  
and Chief Financial Officer

**REPORT OF INDEPENDENT REGISTERED PUBLIC ACCOUNTING FIRM**

To the Board of Directors and  
Stockholders of Cheniere Energy, Inc.:

We have audited the accompanying consolidated balance sheets of Cheniere Energy, Inc. and subsidiaries, or the Company, as of December 31, 2005 and 2004, and the related consolidated statements of operations, stockholders' equity and cash flows for each of the three years in the period ended December 31, 2005. These consolidated financial statements are the responsibility of the Company's management. Our responsibility is to express an opinion on these consolidated financial statements based on our audits. We did not audit the financial statements of Freeport LNG Development, L.P., or Freeport LNG, an investment which, as discussed in Note 8 to the consolidated financial statements, is accounted for by the equity method of accounting. The investment in Freeport LNG was zero and \$(1,071,000) as of December 31, 2005 and 2004, respectively, and the equity in its net loss was \$1,031,000, \$1,346,000 and \$4,471,000, respectively, for each of the three years in the period ended December 31, 2005. The financial statements of Freeport LNG were audited by other auditors whose report has been furnished to us, and our opinion, insofar as it relates to the amounts included for Freeport LNG, are based solely on the report of the other auditors.

We conducted our audits in accordance with the standards of the Public Company Accounting Oversight Board (United States). Those standards require that we plan and perform the audits to obtain reasonable assurance about whether the financial statements are free of material misstatement. An audit includes examining, on a test basis, evidence supporting the amounts and disclosures in the financial statements. An audit also includes assessing the accounting principles used and significant estimates made by management, as well as evaluating the overall financial statement presentation. We believe that our audits provide a reasonable basis for our opinion.

In our opinion, based on our audits and the report of other auditors, the consolidated financial statements referred to above present fairly, in all material respects, the consolidated financial position of Cheniere Energy, Inc. and subsidiaries at December 31, 2005 and 2004, and the consolidated results of their operations and their cash flows for each of the three years in the period ended December 31, 2005, in conformity with accounting principles generally accepted in the United States of America.

We also have audited, in accordance with the standards of the Public Company Accounting Oversight Board (United States), the effectiveness of Cheniere Energy, Inc. and subsidiaries' internal control over financial reporting as of December 31, 2005, based on criteria established in *Internal Control—Integrated Framework* issued by the Committee of Sponsoring Organizations of the Treadway Commission (COSO), and our report dated March 10, 2006 expressed an unqualified opinion on management's assessment of, and the effective operation of, internal control over financial reporting.

/s/ UHY MANN FRANKFORT STEIN & LIPP CPAs, LLP  

---

UHY MANN FRANKFORT STEIN & LIPP CPAs, LLP

Houston, Texas  
March 10, 2006

**REPORT OF INDEPENDENT REGISTERED PUBLIC ACCOUNTING FIRM**

The Board of Directors and  
Stockholders of Cheniere Energy, Inc.:

We have audited management's assessment, included in the accompanying Management's Report on Internal Control Over Financial Reporting appearing on page 73, that Cheniere Energy, Inc. and subsidiaries, or the Company, maintained effective internal control over financial reporting as of December 31, 2005, based on criteria established in *Internal Control—Integrated Framework* issued by the Committee of Sponsoring Organizations of the Treadway Commission (COSO). The Company's management is responsible for maintaining effective internal control over financial reporting and for its assessment of the effectiveness of internal control over financial reporting. Our responsibility is to express an opinion on management's assessment and an opinion on the effectiveness of the Company's internal control over financial reporting based on our audit.

We conducted our audit in accordance with the standards of the Public Company Accounting Oversight Board (United States). Those standards require that we plan and perform the audit to obtain reasonable assurance about whether effective internal control over financial reporting was maintained in all material respects. Our audit included obtaining an understanding of internal control over financial reporting, evaluating management's assessment, testing and evaluating the design and operating effectiveness of internal control, and performing such other procedures as we considered necessary in the circumstances. We believe that our audit provides a reasonable basis for our opinion.

A company's internal control over financial reporting is a process designed to provide reasonable assurance regarding the reliability of financial reporting and the preparation of financial statements for external purposes in accordance with generally accepted accounting principles. A company's internal control over financial reporting includes those policies and procedures that (1) pertain to the maintenance of records that, in reasonable detail, accurately and fairly reflect the transactions and dispositions of the assets of the company; (2) provide reasonable assurance that transactions are recorded as necessary to permit preparation of financial statements in accordance with generally accepted accounting principles, and that receipts and expenditures of the company are being made only in accordance with authorizations of management and directors of the company; and (3) provide reasonable assurance regarding prevention or timely detection of unauthorized acquisition, use, or disposition of the company's assets that could have a material effect on the financial statements.

Because of its inherent limitations, internal control over financial reporting may not prevent or detect misstatements. Also, projections of any evaluation of effectiveness to future periods are subject to the risk that controls may become inadequate because of changes in conditions, or that the degree of compliance with the policies or procedures may deteriorate.

In our opinion, management's assessment that Cheniere Energy, Inc. and subsidiaries maintained effective internal control over financial reporting as of December 31, 2005, is fairly stated, in all material respects, based on criteria established in *Internal Control—Integrated Framework* issued by COSO. Also, in our opinion, Cheniere Energy, Inc. and subsidiaries maintained, in all material respects, effective internal control over financial reporting as of December 31, 2005, based on criteria established in *Internal Control—Integrated Framework* issued by COSO.

We have also audited, in accordance with the standards of the Public Company Accounting Oversight Board (United States), the consolidated balance sheets of Cheniere Energy, Inc. and subsidiaries as of December 31, 2005 and 2004, and the related consolidated statements of operations, stockholders' equity, and cash flows for each of the three years in the period ended December 31, 2005, and our report dated March 10, 2006 expressed an unqualified opinion on those consolidated financial statements.

/s/ UHY MANN FRANKFORT STEIN & LIPP CPAs, LLP  
**UHY MANN FRANKFORT STEIN & LIPP CPAs, LLP**

Houston, Texas  
March 10, 2006

**CHENIERE ENERGY, INC. AND SUBSIDIARIES**  
**CONSOLIDATED BALANCE SHEET**  
(in thousands, except share data)

	December 31,	
	2005	2004
<u>ASSETS</u>		
<b>CURRENT ASSETS</b>		
Cash and Cash Equivalents	\$ 692,592	\$ 308,443
Restricted Cash and Cash Equivalents	160,885	—
Restricted Certificate of Deposit	676	900
Advances to EPC Contractor	8,087	—
Accounts Receivable	2,912	1,374
Derivative Assets	5,468	—
Prepaid Expenses	843	564
	871,463	311,281
<b>NON-CURRENT RESTRICTED CASH AND CASH EQUIVALENTS</b>		
	16,500	—
<b>PROPERTY, PLANT AND EQUIPMENT, NET</b>		
	298,083	20,880
<b>DEBT ISSUANCE COSTS, NET</b>		
	43,008	1,302
<b>INVESTMENT IN LIMITED PARTNERSHIP</b>		
	—	—
<b>GOODWILL</b>		
	76,844	—
<b>LONG-TERM DERIVATIVE ASSETS</b>		
	1,837	—
<b>INTANGIBLE LNG ASSETS</b>		
	93	88
<b>OTHER</b>		
	296	16
	\$ 1,308,124	\$ 333,567
<u>LIABILITIES AND STOCKHOLDERS' EQUITY</u>		
<b>CURRENT LIABILITIES</b>		
Accounts Payable	\$ 778	\$ 1,262
Accrued Liabilities	54,544	3,196
Accrued Losses on Investment in Limited Partnership	—	1,071
Current Portion of Long-Term Debt	6,000	—
	61,322	5,529
<b>LONG-TERM DEBT</b>		
	917,500	—
<b>DEFERRED REVENUE</b>		
	41,000	23,000
<b>LONG-TERM DERIVATIVE LIABILITIES</b>		
	1,682	—
<b>LONG-TERM ASSET RETIREMENT OBLIGATION</b>		
	102	99
<b>MINORITY INTEREST</b>		
	—	338
<b>COMMITMENTS AND CONTINGENCIES</b>		
	—	—
<b>STOCKHOLDERS' EQUITY</b>		
<b>Preferred Stock, \$.0001 par value</b>		
Authorized: 5,000,000 shares		
Issued and Outstanding: none		
	—	—
<b>Common Stock, \$.003 par value</b>		
Authorized: 120,000,000 and 40,000,000 shares at December 31, 2005		
and December 31, 2004, respectively		
Issued and Outstanding: 54,521,131 and 50,918,582 shares at December 31, 2005 and December 31, 2004, respectively		
	164	153
<b>Additional Paid-in-Capital</b>		
	375,551	364,504
<b>Deferred Compensation</b>		
	(9,684)	(6,543)
<b>Accumulated Deficit</b>		
	(83,311)	(53,513)
<b>Accumulated Other Comprehensive Income</b>		
	3,798	—
	286,518	304,601
	\$ 1,308,124	\$ 333,567

The accompanying notes are an integral part of these financial statements.

[Table of Contents](#)

**CHENIERE ENERGY, INC. AND SUBSIDIARIES**  
**CONSOLIDATED STATEMENT OF OPERATIONS**  
(in thousands, except per share data)

	Year Ended December 31,		
	2005	2004	2003
<b>Revenues</b>			
Oil and Gas Sales	\$ 3,005	\$ 1,998	\$ 658
<b>Total Revenues</b>	<b>3,005</b>	<b>1,998</b>	<b>658</b>
<b>Operating Costs and Expenses</b>			
LNG Receiving Terminal Development Expenses	22,020	17,166	6,705
Oil and Gas Production Costs	237	117	—
Depreciation, Depletion and Amortization	3,702	1,324	429
General and Administrative Expenses	29,145	12,476	2,542
<b>Total Operating Costs and Expenses</b>	<b>55,104</b>	<b>31,083</b>	<b>9,676</b>
<b>Loss from Operations</b>	<b>(52,099)</b>	<b>(29,085)</b>	<b>(9,018)</b>
Gain on Sale of Investment in Unconsolidated Affiliate	20,206	—	—
Equity in Net Loss of Limited Partnership	(1,031)	(1,346)	(4,471)
Gain on Sale of LNG Assets	—	—	4,760
Gain on Sale of Limited Partnership Interest	—	—	423
Reimbursement from Limited Partnership Investment	—	2,500	—
Derivative Gain	837	—	—
Interest Expense	(17,373)	—	—
Interest Income	17,520	501	3
<b>Loss Before Income Taxes and Minority Interest</b>	<b>(31,940)</b>	<b>(27,430)</b>	<b>(8,303)</b>
Income Tax Benefit	2,045	—	—
<b>Loss Before Minority Interest</b>	<b>(29,895)</b>	<b>(27,430)</b>	<b>(8,303)</b>
Minority Interest	97	2,862	3,015
<b>Net Loss</b>	<b>\$ (29,798)</b>	<b>\$ (24,568)</b>	<b>\$ (5,288)</b>
<b>Net Loss Per Common Share—Basic and Diluted</b>	<b>\$ (0.56)</b>	<b>\$ (0.63)</b>	<b>\$ (0.18)</b>
<b>Weighted Average Number of Common Shares Outstanding—Basic and Diluted</b>	<b>53,097</b>	<b>38,895</b>	<b>29,543</b>

The accompanying notes are an integral part of these financial statements.

**CHENIERE ENERGY, INC. AND SUBSIDIARIES**  
**CONSOLIDATED STATEMENT OF STOCKHOLDERS' EQUITY**  
(in thousands)

	Common Stock		Additional Paid-In Capital	Deferred Compensation	Accumulated Deficit	Accumulated Other Comprehensive Income	Total Stockholders' Equity
	Shares	Amount					
Balance—December 31, 2002	26,594	\$ 80	\$ 41,374	\$ —	\$ (23,657)	\$ —	\$ 17,797
Issuances of Stock	6,382	19	5,723	—	—	—	5,742
Issuances of Warrants	—	—	945	—	—	—	945
Expenses Related to Offerings	—	—	(57)	—	—	—	(57)
Net Loss	—	—	—	—	(5,288)	—	(5,288)
Balance—December 31, 2003	32,976	\$ 99	\$ 47,985	—	\$ (28,945)	\$ —	\$ 19,139
Issuances of Stock	17,263	52	323,295	—	—	—	323,347
Issuances of Restricted Stock	680	2	8,274	(8,276)	—	—	—
Amortization of Deferred Compensation	—	—	—	1,733	—	—	1,733
Expenses Related to Offerings	—	—	(15,050)	—	—	—	(15,050)
Net Loss	—	—	—	—	(24,568)	—	(24,568)
Balance—December 31, 2004	50,919	\$ 153	\$ 364,504	\$ (6,543)	\$ (53,513)	\$ —	\$ 304,601
Issuances of Stock	3,427	10	80,115	—	—	—	80,125
Issuances of Restricted Stock	175	1	6,662	(6,663)	—	—	—
Amortization of Deferred Compensation	—	—	—	3,522	—	—	3,522
Expenses Related to Offerings	—	—	(27)	—	—	—	(27)
Purchase of Issuer Call Spread	—	—	(75,703)	—	—	—	(75,703)
Comprehensive Gain on Interest Rate Swaps, net of income taxes	—	—	—	—	—	3,798	3,798
Net Loss	—	—	—	—	(29,798)	—	(29,798)
Balance—December 31, 2005	54,521	\$ 164	\$ 375,551	\$ (9,684)	\$ (83,311)	\$ 3,798	\$ 286,518

The accompanying notes are an integral part of these financial statements.



**CHENIERE ENERGY, INC. AND SUBSIDIARIES**  
**CONSOLIDATED STATEMENT OF CASH FLOWS**  
(in thousands)

	Year Ended December 31,		
	2005	2004	2003
<b>CASH FLOWS FROM OPERATING ACTIVITIES:</b>			
Net Loss	\$ (29,798)	\$ (24,568)	\$ (5,288)
Adjustments to Reconcile Net Loss to Net Cash Used In Operating Activities:			
Depreciation, Depletion and Amortization	3,702	1,324	429
Non-Cash Compensation	3,438	3,618	—
Gain on Sale of Investment in Unconsolidated Affiliate	(20,206)	—	—
Deferred Tax Benefit	(2,045)	—	—
Reimbursement from Limited Partnership Investment	—	(2,500)	—
Equity in Net Loss of Limited Partnership	1,031	1,346	4,471
Gain on Sale of LNG Assets	—	—	(4,760)
Gain on Sale of Limited Partnership Interest	—	—	(423)
Minority Interest	(97)	(2,862)	(3,015)
Non-Cash Derivative Gain	(871)	—	—
Other	1,857	(18)	(4)
Changes in Operating Assets and Liabilities			
Accounts Receivable—Affiliates	—	1,000	—
Other Accounts Receivable	(320)	(890)	230
Prepaid Expenses	(280)	(257)	(483)
Deferred Revenue	18,000	22,000	—
Accounts Payable and Accrued Liabilities	7,195	1,146	1,284
<b>NET CASH USED IN OPERATING ACTIVITIES</b>	<b>(18,394)</b>	<b>(661)</b>	<b>(7,559)</b>
<b>CASH FLOWS FROM INVESTING ACTIVITIES:</b>			
LNG Terminal Construction-In-Progress	(229,705)	—	—
Investment in Restricted Cash and Cash Equivalents	(177,385)	—	—
Advance to EPC Contractor, net of transfers to Construction- In-Progress	(8,087)	—	—
Purchases of Fixed Assets	(5,811)	(915)	(341)
Investment in Limited Partnership	(2,102)	(275)	—
Oil and Gas Property Additions	(3,861)	(2,025)	(2,514)
Proceeds from Sale of Investment in Unconsolidated Affiliate	20,206	—	—
Reimbursement from Limited Partnership Investment	—	2,500	—
Sale of LNG Assets	—	—	1,873
Sale of Interest in Oil and Gas Prospects	1,235	2,381	392
Other	(639)	(481)	620
<b>NET CASH PROVIDED BY (USED IN) INVESTING ACTIVITIES</b>	<b>(406,149)</b>	<b>1,185</b>	<b>30</b>
<b>CASH FLOWS FROM FINANCING ACTIVITIES:</b>			
Proceeds from Issuances of Notes Payable	—	—	1,225
Issuance of Convertible Senior Unsecured Notes	325,000	—	—
Proceeds from Term Loan	600,000	—	—
Repayment of Term Loan	(1,500)	—	—
Purchase of Issuer Call Spread	(75,703)	—	—
Debt Issuance Costs	(42,124)	(1,302)	—
Sale of Common Stock	2,972	320,933	4,429
Offering Costs	(27)	(15,050)	(57)
Repayment of Note Payable	—	(1,000)	(225)
Partnership Contributions by Minority Owner	74	3,080	2,825
<b>NET CASH PROVIDED BY FINANCING ACTIVITIES</b>	<b>808,692</b>	<b>306,661</b>	<b>8,197</b>
<b>NET INCREASE IN CASH AND CASH EQUIVALENTS</b>	<b>384,149</b>	<b>307,185</b>	<b>668</b>
<b>CASH AND CASH EQUIVALENTS—BEGINNING OF YEAR</b>	<b>308,443</b>	<b>1,258</b>	<b>590</b>
<b>CASH AND CASH EQUIVALENTS—END OF YEAR</b>	<b>\$ 692,592</b>	<b>\$308,443</b>	<b>\$ 1,258</b>

The accompanying notes are an integral part of these financial statements.

**CHENIERE ENERGY, INC. AND SUBSIDIARIES**  
**NOTES TO CONSOLIDATED FINANCIAL STATEMENTS**

**NOTE 1—ORGANIZATION AND NATURE OF OPERATIONS**

Cheniere Energy, Inc., a Delaware corporation, is a Houston-based company engaged, through its subsidiaries, in the energy business generally. As used in these Notes to Consolidated Financial Statements, the terms “we”, “us” and “our” refer to Cheniere Energy, Inc. and its subsidiaries. We are currently engaged primarily in the business of developing and constructing, and then owning and operating, a network of three onshore LNG receiving terminals, and related natural gas pipelines, along the Gulf Coast of the United States. We are also engaged, to a limited extent, in oil and natural gas exploration and development activities in the Gulf of Mexico.

**NOTE 2—SUMMARY OF SIGNIFICANT ACCOUNTING POLICIES**

**Basis of Presentation**

The consolidated financial statements include the accounts of Cheniere Energy, Inc. and its majority-owned subsidiaries. We also hold ownership interests in entities that are accounted for under the equity and cost methods of accounting. All significant intercompany accounts and transactions have been eliminated in consolidation. Certain items in the prior year financial statements have been reclassified to conform with the 2005 presentation.

All references to issued and outstanding shares, weighted average shares, and per share amounts in the accompanying consolidated financial statements have been retroactively adjusted to reflect our two-for-one stock split that occurred on April 22, 2005.

**Accounting for LNG Activities**

We begin capitalizing the costs of our LNG receiving terminals and related pipelines once the individual project meets the following criteria: (i) regulatory approval has been received, (ii) financing for the project is available and (iii) management has committed to commence construction. Prior to meeting these criteria, most of the costs associated with a project are expensed as incurred. These costs primarily include professional fees associated with front-end engineering and design work, costs of securing necessary regulatory approvals, and other preliminary investigation and development activities related to our LNG receiving terminals and related natural gas pipelines.

Costs that are capitalized prior to a project meeting the criteria otherwise necessary for capitalization include: land costs, costs of lease options and the cost of certain permits which are capitalized as intangible LNG assets. The costs of lease options are amortized over the life of the lease once it is obtained. If no lease is obtained the costs are expensed. Site rental costs and related amortization of capitalized options have been capitalized during the construction period through the end of 2005. Beginning in 2006, such costs will be expensed as required by Financial Accounting Standards Board, or FASB, Staff Position, or FSP, 13-1, *Accounting for Rental Cost Incurred During Construction*.

During the construction periods of our LNG receiving terminals and related pipelines, we capitalize interest and other related debt costs in accordance with Statement of Financial Accounting Standards, or SFAS, No. 34, *Capitalization of Interest Cost*, as amended by SFAS No. 58, *Capitalization of Interest Cost in Financial Statements That Include Investments Accounted for by the Equity Method (an Amendment of FASB Statement No. 34)*. Upon commencement of operations, capitalized interest, as a component of the total cost, will be amortized over the estimated useful life of the asset.

**CHENIERE ENERGY, INC. AND SUBSIDIARIES**  
**NOTES TO CONSOLIDATED FINANCIAL STATEMENTS—(Continued)**

**Full Cost Method of Accounting**

We follow the full cost method of accounting for our oil and gas properties. Under this method, all productive and nonproductive exploration and development costs incurred for the purpose of finding oil and gas reserves are capitalized. Such capitalized costs include lease acquisition, geological and geophysical work, delay rentals, drilling, completing and equipping oil and gas wells, together with internal costs directly attributable to property acquisition, exploration and development activities. We capitalized general and administrative expenses, totaling \$927,000, \$1,569,000 and \$976,000 for the years 2005, 2004 and 2003, respectively.

The costs of our oil and gas properties, including the estimated future costs to develop proved reserves and the carrying amounts of any asset retirement obligations, are depreciated using a composite unit-of-production rate based on estimates of proved reserves. Investments in unproved properties and major development projects are not amortized until proved reserves associated with the projects can be determined or until impairment occurs. If the results of an assessment indicate that the properties are impaired, then the amount of the impairment is added to the capitalized costs being amortized. Net capitalized costs are limited to a capitalization ceiling, calculated on a quarterly basis as the aggregate of the present value, discounted at 10%, of estimated future net revenues from proved reserves (based on current economic and operating conditions), but excluding asset retirement obligations, plus the lower of cost or fair market value of unproved properties, less related income tax effects.

Our allocation of seismic exploration costs between proved and unproved properties involves an estimate of the total reserves to be discovered through our exploration program. This estimate includes a number of assumptions that we have incorporated into a three-year plan. Such factors include an estimate of the number of exploration prospects generated, prospect reserve potential, success ratios and ownership interests. We transfer seismic exploration costs to proved properties based on a ratio of proved reserves discovered at a point in time to the estimate of total reserves to be discovered in our exploration program. The carrying value of unproved properties is evaluated for possible impairment by comparing it to the estimated future net cash flows associated with the estimated total reserves to be discovered in our exploration program. To the extent that the carrying value of unproved properties is greater than the estimated future net revenue, any excess is transferred to proved properties. It is reasonably possible, based on the results obtained from future drilling and prospect generation, that revisions to this estimate of total reserves to be discovered could affect our capitalization ceiling.

Sales of proved and unproved properties are accounted for as adjustments of capitalized costs with no gain or loss recognized, unless such adjustments would significantly alter the relationship between capitalized costs and proved oil and gas reserves.

We account for the retirement of our tangible long-lived assets in accordance with SFAS No. 143, *Accounting for Asset Retirement Obligations*. SFAS No. 143 requires us to record the fair value of a liability for legal obligations associated with the retirement of tangible long-lived assets and a corresponding increase in the carrying amount of the related long-lived assets. Subsequently, the asset retirement costs included in the carrying amount of the related asset are allocated to expense using the unit-of-production method used to depreciate oil and gas properties under the full cost method of accounting.

On January 1, 2003, the date of adoption of SFAS No. 143, we had no legal obligations associated with the retirement of any long-lived assets, as all of our oil and gas property interests were non-cost bearing overriding royalty interests, or ORRI. In 2004, we converted an ORRI to a working interest at well payout. As a result, we recorded \$97,000, the present value of the expected abandonment cost of the well and related equipment, as a long-term asset retirement obligation and a corresponding amount to proved oil and gas properties. Accretion expense for 2005 and 2004 was \$3,000 and \$2,000, respectively, and was included in depreciation, depletion and amortization expense. The resulting long-term asset retirement obligation was \$102,000 at December 31, 2005.

**CHENIERE ENERGY, INC. AND SUBSIDIARIES**  
**NOTES TO CONSOLIDATED FINANCIAL STATEMENTS—(Continued)**

**Revenue Recognition**

LNG regasification capacity fees are recognized as revenue over the term of the respective terminal use agreement, or TUA. Advance capacity reservation fees are initially deferred.

Revenues from the sale of oil and gas production are recognized upon passage of title, net of royalty interests. When sales volumes differ from our entitled share, an under produced or overproduced imbalance occurs. To the extent an overproduced imbalance exceeds our share of the remaining estimated proved natural gas reserves for a given property, we record a liability. At December 31, 2005 and 2004, we had no gas imbalances.

**Fixed Assets**

Fixed assets are recorded at cost. Repairs and maintenance costs are charged to operations as incurred. Depreciation is computed using the straight-line method over estimated useful lives of the assets, which range from two to ten years. Upon retirement or other disposition of fixed assets, the cost and related accumulated depreciation are removed from the account and the resulting gains or losses are recorded.

**Offering Costs**

Offering costs consist primarily of underwriter's fees, placement fees, professional fees, legal fees and printing costs. These costs are charged against the related proceeds from the sale of common stock in the periods in which they occur or charged to expense in the event of a terminated offering.

**Income Taxes**

Provisions for income taxes are based on taxes payable or refundable for the current year and deferred taxes on temporary differences between the tax basis of assets and liabilities and their reported amounts in the consolidated financial statements. Deferred tax assets and liabilities are included in the consolidated financial statements at currently enacted income tax rates applicable to the period in which the deferred tax assets and liabilities are expected to be realized or settled as prescribed in SFAS No. 109, *Accounting for Income Taxes*. As changes in tax laws or rates are enacted, deferred tax assets and liabilities are adjusted through the current period's provision for income taxes. A valuation allowance is provided for deferred tax assets if it is more likely than not that such asset will not be realizable.

**Cash Flow Hedges**

Cash flow hedges are used to limit our exposure to variability in expected future cash flows (in our case, the variability of floating interest rate exposure). The hedged item (the underlying risk) is generally unrecognized (i.e., not recorded on the balance sheet prior to settlement), and any changes in the fair value, therefore, will not be recorded within earnings. Conceptually, if a cash flow hedge is effective, this means that a variable, such as a movement in interest rates, has been effectively fixed so that any fluctuations will have no net result on either cash flows or earnings. Therefore, if the changes in fair value of the hedged item are not recorded in earnings, then the changes in fair value of the hedging instrument (the derivative) must also be excluded from the income statement or else a one-sided net impact on earnings will be reported, despite the fact that the establishment of the effective hedge results in no net economic impact. To prevent such a scenario from occurring, SFAS No. 133, *Accounting for Derivative Instruments and Hedging Activities, as amended*, requires that the fair value of a derivative instrument designated as a cash flow hedge be recorded as an asset or liability on the balance sheet, but with the offset reported as part of other comprehensive income, to the extent that the hedge is effective. Any ineffective portion will be reflected in earnings.

**CHENIERE ENERGY, INC. AND SUBSIDIARIES**  
**NOTES TO CONSOLIDATED FINANCIAL STATEMENTS—(Continued)**

**Use of Estimates**

The preparation of financial statements in conformity with accounting principles generally accepted in the United States of America requires that we make estimates and assumptions that affect the amounts reported in the consolidated financial statements and the accompanying notes. Actual results could differ from the estimates and assumptions used. Depletion of oil and gas properties is determined using estimates of proved oil and gas reserves. There are numerous uncertainties inherent in the estimation of quantities of proved reserves. Similarly, total reserves to be discovered through our exploration program are subject to numerous uncertainties including estimates of future recoverable reserves and commodity price outlook. Other estimates which may impact our financial statements include the fair value of our interest rate derivatives and estimates used in determining the effectiveness of derivatives designated as hedges.

**Cash Equivalents**

We classify all investments with original maturities of three months or less as cash equivalents. Our investments are primarily in commercial paper and are made in accordance with corporate policy, which, among other things, stipulates minimum acceptable credit ratings of commercial paper issuers.

**Fair Value of Financial Instruments**

The carrying amounts of cash and cash equivalents, restricted cash and cash equivalents, restricted certificates of deposit, accounts receivable, and accounts payable approximate fair value because of the short maturity of those instruments. We use available market data and valuation methodologies to estimate the fair value of debt.

**Commodity Price Risk**

We produce and sell natural gas, crude oil and condensate. As a result, our financial results can be affected as these commodity prices fluctuate widely in response to changing market forces. We had not entered into any commodity hedging transactions as of December 31, 2005.

**Concentration of Credit Risk**

All of our revenues are attributable to properties operated by three companies. These companies sell our share of production for us, pay the associated severance taxes, and remit the balance to us. Our products are commodities and have a readily available market for sale.

We maintain funds in bank accounts that exceed the limit insured by the Federal Deposit Insurance Corporation, or FDIC. Accounts are guaranteed by the FDIC up to \$100,000. The risk of loss attributable to these uninsured balances is mitigated by depositing funds only in commercial banks with minimum Standard & Poor's and Moody's Investor Service ratings of A and Aa3, respectively. We have not experienced any losses in such accounts.

We have entered into certain long-term TUAs with unaffiliated third parties for regasification capacity at our proposed Sabine Pass LNG receiving terminal. We are dependent on the respective counterparties' creditworthiness and their willingness to perform under their respective TUAs. We have mitigated this credit risk by securing TUAs with creditworthy third-party customers with a minimum Standard & Poor's rating of AA.

**Goodwill**

As further described in Note 9—"Goodwill", we account for goodwill in accordance with the provisions of SFAS No. 142, *Goodwill and Other Intangible Assets*. Under the provisions of that statement, we are required to

**CHENIERE ENERGY, INC. AND SUBSIDIARIES**  
**NOTES TO CONSOLIDATED FINANCIAL STATEMENTS—(Continued)**

perform an annual review of goodwill for impairment. This review is required to be done at the reporting unit level, which we have determined to be our LNG receiving terminals business, which is a component of our LNG receiving terminal development business segment. We perform the annual review for possible impairment in the fourth calendar quarter of each year. If an event or change in circumstances indicate the fair value of a reporting unit may be below its carrying value, an impairment test would be performed sooner than the annual review date.

**Debt Issuance Costs**

Debt issuance costs consist primarily of arrangement fees, professional fees, legal fees and printing costs. These costs are capitalized and are amortized to interest expense over the term of the related debt facility.

**Stock-Based Compensation**

SFAS No. 123, *Accounting for Stock-Based Compensation*, encourages, but does not require, companies to record compensation cost for stock-based employee compensation plans at fair value. In December 2002, the FASB issued SFAS No. 148, *Accounting for Stock-Based Compensation—Transition and Disclosure—an amendment of SFAS No. 123*, to provide alternative methods of transition for a voluntary change to the fair value based method of accounting for stock-based employee compensation. The statement also amends the disclosure requirements of SFAS No. 123 to require prominent disclosures in both annual and interim financial statements about the method of accounting for stock-based compensation and the effect of the method used on reported results.

We have chosen to continue to account for stock-based compensation issued to employees using the intrinsic value method prescribed in Accounting Principles Board, or APB, Opinion No. 25, *Accounting for Stock Issued to Employees*, and related interpretations. Accordingly, compensation cost for stock options is measured as the excess, if any, of the quoted market price of our stock at the date of the grant over the amount an employee must pay to acquire the stock. We grant options at or above the market price of its common stock at the date of each grant.

The fair value of options is calculated using the Black-Scholes option-pricing model. Had we adopted the fair value method of accounting for stock-based compensation, compensation expense would have been higher, and net loss attributable to common stockholders would have increased for the periods presented. No change in cash flows would occur. The effects of applying SFAS No. 123 in this pro forma disclosure are not indicative of future amounts.

	Year Ended December 31,		
	2005	2004	2003
	(in thousands, except per share amounts)		
Net loss as reported	\$ (29,798)	\$ (24,568)	\$ (5,288)
Add: Stock-based employee compensation included in net loss	61	—	—
Deduct:			
Total stock-based employee compensation expense determined under fair value method for all awards, net of related income tax	(13,045)	(2,206)	(967)
Pro forma net loss	\$ (42,782)	\$ (26,774)	\$ (6,255)
Net loss per share			
Basic and diluted—as reported	\$ (0.56)	\$ (0.63)	\$ (0.18)
Basic and diluted—pro forma	\$ (0.81)	\$ (0.69)	\$ (0.21)

**CHENIERE ENERGY, INC. AND SUBSIDIARIES**  
**NOTES TO CONSOLIDATED FINANCIAL STATEMENTS—(Continued)**

From our inception, we have recorded annual net operating losses for both financial reporting purposes and for federal and state income tax reporting purposes. Accordingly, we are not presently a taxpayer, and therefore there is no tax effect on stock-based employee compensation expense.

The weighted average fair value of warrants and options granted as employee compensation during 2005, 2004 and 2003 was \$20.16, \$5.82 and \$0.72, respectively. The fair values were determined using the Black-Scholes option-pricing model with the following weighted average assumptions, and a forfeiture rate that is assumed to be negligible:

	Year Ended December 31,		
	2005	2004	2003
Dividend yield	0.0%	0.0%	0.0%
Weighted average volatility	96.3%	95.9%	107.5%
Risk-free interest rate	4.2%	3.4%	3.0%
Expected lives of options	6.4 years	4.0 years	4.0 years

**Net Loss Per Share**

Net loss per share, or EPS, is computed in accordance with the requirements of SFAS No. 128, *Earnings Per Share*. Basic EPS excludes dilution and is computed by dividing net income (loss) by the weighted average number of common shares outstanding during the period. Diluted EPS reflects potential dilution and is computed by dividing net income by the weighted average number of common shares outstanding during the period increased by the number of additional common shares that would have been outstanding if the potential common shares had been issued. Basic and diluted EPS for all periods presented are the same since the effect of our options and warrants is anti-dilutive to our net loss per share under SFAS No. 128. Stock options, warrants and unvested stock representing securities that could potentially dilute basic EPS in the future that were not included in the diluted computation because they would have been anti-dilutive for the years 2005, 2004 and 2003 were 5,680,000, 3,133,000 and 6,519,000 respectively. In addition, common shares of 3,972,000 on a weighted average basis, issuable upon conversion of the Convertible Senior Unsecured Notes (described in Note 14 —“Long-Term Debt”), were not included in the computation of diluted net loss per share for 2005 because the computation of diluted net loss per share utilizing the “if-converted” method would be anti-dilutive. No adjustments were made to reported net loss in the computation of EPS.

We entered into an issuer call spread (an instrument that combines the purchase and sale of call options on our common stock) to offset the potential dilution from conversion of our Convertible Senior Unsecured Notes. Purchased call options are always excluded from the calculation of diluted earnings per share because they are anti-dilutive. SFAS No. 128 requires that we include the sold call options in the calculation of diluted earnings per share using the treasury stock method whenever the average market price of our common shares exceeds the strike price of the call options. The strike price of the sold call options is \$70 per share, which is greater than the average market price of our common stock for 2005; thus, the sold call options were not included in the calculation of diluted earnings per share. The total number of shares that could potentially be included under the sold call options is 9,176,000.

**New Accounting Pronouncements**

In December 2004, the FASB issued SFAS No. 123R, *Share-Based Payment*, that addresses the accounting for share-based payment transactions in which a company receives employee services in exchange for equity instruments of the company, such as stock options and non-vested stock. SFAS No. 123R eliminates the ability to account for share-based compensation transactions using APB Opinion No. 25 and requires instead that such

**CHENIERE ENERGY, INC. AND SUBSIDIARIES**  
**NOTES TO CONSOLIDATED FINANCIAL STATEMENTS—(Continued)**

transactions be accounted for using a fair value-based method. From inception through December 31, 2005, we have accounted for stock-based compensation using the intrinsic method pursuant to APB Opinion No. 25. SFAS No. 123R requires that all stock-based payments to employees, including grants of employee stock options and non-vested stock, be recognized as compensation expense in the financial statements based on their fair values (intrinsic valued in the case of restricted stock) at the time such awards are granted. SFAS No. 123R is effective January 1, 2006 for companies with fiscal years ending December 31. Accordingly, we will begin reporting the results of SFAS No. 123R on our operations in the quarter ending March 31, 2006. We are adopting the new standard using the modified-prospective transition method. The adoption of the new standard will have a significant future impact on our results of operations, but will have no impact on our future cash flows. Had we adopted SFAS No. 123R in prior periods, the effects of that standard on net income and earnings per share would have been approximately the same as the effects of SFAS No. 123 shown in the Stock-Based Compensation proforma disclosure presented previously.

In May 2005, the FASB issued SFAS No. 154, *Accounting Changes and Error Corrections—A Replacement of APB Opinion No. 20 and FASB Statement No. 3*. SFAS No. 154 changes the requirements for accounting and reporting on a change in accounting principle, while carrying forward the guidance in APB Opinion No. 20, *Accounting Changes* and FASB Statement No. 3, *Reporting Accounting Changes in Interim Financial Statements*, with respect to accounting for changes in estimates, changes in the reporting entity and the correction of errors. APB Opinion No. 20 previously required that most voluntary changes in accounting principle be recognized by including in net income of the period of the change, the cumulative effect of changing to the new accounting principle. SFAS No. 154 requires retrospective application to prior periods' financial statements for voluntary changes in accounting principle, unless it is impracticable to determine either the period-specific effects or the cumulative effect of the change. SFAS No. 154 is effective for accounting changes and corrections of errors made in fiscal years beginning after December 15, 2005. The impact of SFAS No. 154 will depend on an accounting change that may occur in a future period.

In October 2005, the FASB issued FSP 13-1, *Accounting for Rental Costs Incurred During a Construction Period*, to address the accounting for rental costs associated with operating leases that are incurred during a construction period. FSP 13-1 requires rental costs associated with ground or building operating leases that are incurred during a construction period to be recognized as rental expense. FSP 13-1 is effective in fiscal years beginning after December 15, 2005. Accordingly, we will adopt the new standard in the quarter ending March 31, 2006. As of December 31, 2005, we have capitalized \$1,501,000 in rental costs related to our Sabine Pass LNG receiving terminal site lease. We began expensing these rental costs effective January 1, 2006.

**NOTE 3—RESTRICTED CASH AND CASH EQUIVALENTS**

In February 2005, Sabine Pass LNG, L.P., our wholly-owned subsidiary, or Sabine Pass LNG, entered into an \$822,000,000 credit facility, or the Sabine Pass Credit Facility, with an initial syndicate of 47 financial institutions. Société Générale serves as the administrative agent and HSBC Bank USA, National Association, or HSBC, serves as collateral agent. Under the terms and conditions of the Sabine Pass Credit Facility, all cash held by Sabine Pass LNG is controlled by the collateral agent. These funds can only be released by the collateral agent upon receipt of satisfactory documentation that the Sabine Pass LNG Phase 1 project costs are bona fide expenditures and are permitted under the terms of the Sabine Pass Credit Facility. The Sabine Pass Credit Facility does not permit Sabine Pass LNG to hold any cash, or cash equivalents, outside of the accounts established under the agreement. Because these cash accounts are controlled by the collateral agent, the Sabine Pass LNG cash balance of \$8,871,000 held in these accounts as of December 31, 2005 is classified as restricted on our balance sheet.

In August 2005, Cheniere LNG Holdings, LLC, our wholly-owned subsidiary, or Cheniere LNG Holdings, entered into a \$600,000,000 Senior Secured Term Loan, or the Term Loan, with Credit Suisse, Cayman Islands



**CHENIERE ENERGY, INC. AND SUBSIDIARIES**  
**NOTES TO CONSOLIDATED FINANCIAL STATEMENTS—(Continued)**

Branch, or Credit Suisse, who also serves as collateral agent and administrative agent. Under the conditions of the Term Loan, Cheniere LNG Holdings was required to fund from the loan proceeds a total of \$216,200,000 into two collateral accounts: \$181,000,000 into a debt service reserve collateral account and \$35,200,000 into a capital contribution reserve collateral account. These funds are restricted to the payment of interest and principal due under the Term Loan, reimbursement of certain expenses, and funding of additional capital contributions to Sabine Pass LNG as required under the Sabine Pass Credit Facility. As of December 31, 2005, all additional capital contributions contemplated by the Term Loan have been funded to Sabine Pass LNG. Because the accounts are controlled by the collateral agent, our cash and cash equivalent balance of \$168,514,000 held in these accounts as of December 31, 2005 is classified as restricted on our consolidated balance sheet. Of this amount, \$16,500,000 is classified as non-current due to the timing of certain required debt amortization payments.

**NOTE 4—RESTRICTED CERTIFICATE OF DEPOSIT AND LETTER OF CREDIT**

Under the terms of our office lease, we are required to post a standby letter of credit in favor of the lessor. The initial amount of the letter of credit was increased from \$865,000 to \$1,123,000 in April 2004, which related to the expansion of our office space; and the amount will be reduced by approximately \$225,000 per annum over a five-year period. This letter of credit was initially established under the terms of our bank line of credit in effect at that time.

Upon the termination of our bank line of credit in June 2004, we purchased a certificate of deposit in the amount of \$1,123,000 and entered into a pledge agreement in favor of the commercial bank that had previously issued the standby letter of credit for \$1,123,000. In October 2004 and 2005, both the letter of credit and certificate of deposit were amended to decrease the face amounts by approximately \$225,000 to \$898,000 and \$674,000, respectively. The current letter of credit and the certificate of deposit both mature on November 30, 2006. Under the terms of the pledge agreement, the commercial bank was assigned a security interest in the certificate of deposit as collateral for the letter of credit. As a result, the certificate of deposit plus \$2,000 of accrued interest is classified as restricted on our balance sheet at December 31, 2005.

**NOTE 5—ADVANCES TO EPC CONTRACTOR**

In December 2004, Sabine Pass LNG entered into a lump-sum turnkey EPC contract with Bechtel Corporation, or Bechtel, to construct the initial phase, or Phase 1, of the Sabine Pass LNG receiving terminal. Under the EPC contract, we were required to make a 5% advance payment to Bechtel upon issuance of the final notice to proceed, or NTP, related to the construction of Phase 1. A payment of \$32,347,000 was made to Bechtel in March 2005 when the NTP was issued and that amount was classified on our consolidated balance sheet as a current asset. In accordance with the payment schedule included in the EPC contract, \$2,696,000 per month is being reclassified to construction-in-progress over a twelve-month period. As of December 31, 2005, the remaining balance of the advance was \$8,087,000.

**CHENIERE ENERGY, INC. AND SUBSIDIARIES**  
**NOTES TO CONSOLIDATED FINANCIAL STATEMENTS—(Continued)**

**NOTE 6—PROPERTY, PLANT AND EQUIPMENT**

Property, plant and equipment is comprised of LNG terminal construction-in-progress expenditures, LNG site and related costs, investments in oil and gas properties, and fixed assets, as follows (in thousands):

	December 31,	
	2005	2004
<b>LNG TERMINAL COSTS</b>		
LNG terminal construction-in-progress	\$271,142	\$ —
LNG site and related costs, net	1,249	786
<b>Total LNG Terminal Costs</b>	<b>272,391</b>	<b>786</b>
<b>OIL AND GAS PROPERTIES, full cost method</b>		
Proved	5,787	3,339
Unproved	17,216	16,688
Accumulated depreciation, depletion and amortization	(3,386)	(971)
<b>Total Oil and Gas Properties, net</b>	<b>19,617</b>	<b>19,056</b>
<b>FIXED ASSETS</b>		
Computers and office equipment	3,611	905
Furniture and fixtures	1,145	523
Computer software	1,640	334
Leasehold improvements	1,757	100
Other	26	—
Accumulated depreciation	(2,104)	(824)
<b>Total Fixed Assets, net</b>	<b>6,075</b>	<b>1,038</b>
<b>PROPERTY, PLANT AND EQUIPMENT, net</b>	<b>\$298,083</b>	<b>\$20,880</b>

In February 2005, Phase 1 of our Sabine Pass LNG project satisfied the criteria for capitalization. Accordingly, costs associated with the construction of Phase 1 of our Sabine Pass LNG project have been capitalized as construction-in-progress since that time.

We have made investments in acquiring, processing and reprocessing our seismic databases covering a 6,800-square-mile project area offshore Texas and Louisiana and a 228-square-mile project area onshore and offshore Louisiana. The costs of these projects become subject to amortization on a ratable basis as the oil and gas reserves expected to be recovered from the projects are discovered. We began drilling prospects identified within our seismic databases in 1999. We did not participate directly in drilling any wells during the period from 2001 through 2004, but we retained overriding royalty interests in wells drilled by others on prospects we generated during such period; however, in 2005, we participated directly in the drilling of two wells.

Depreciation, depletion and amortization of oil and gas property costs totaled \$2,415,000, \$835,000 and \$121,000 for the years ended December 31, 2005, 2004 and 2003, respectively. Depreciation, depletion and amortization per equivalent Mcf (using an Mcf-to-barrel conversion factor of 6 to 1) was \$5.90, \$2.48 and \$0.98 for the years ended December 31, 2005, 2004 and 2003, respectively.

Depreciation expense related to our fixed assets totaled \$1,284,000, \$410,000 and \$165,000 for the years ended December 31, 2005, 2004 and 2003, respectively.

**CHENIERE ENERGY, INC. AND SUBSIDIARIES**  
**NOTES TO CONSOLIDATED FINANCIAL STATEMENTS—(Continued)**

**NOTE 7—DEBT ISSUANCE COSTS**

As of December 31, 2005, we have capitalized \$43,008,000 of costs directly associated with the arrangement of debt financing, net of accumulated amortization, as follows:

Debt Facility	Debt Issuance Costs	Amortization Period (1)	Accumulated Amortization	Net Costs
Sabine Pass Credit Facility (2)	\$ 20,176,000	10 years	\$ (1,679,000)	\$ 18,497,000
Convertible Senior Unsecured Notes (3)	9,542,000	7 years	(589,000)	8,953,000
Term Loan (4)	16,083,000	7 years	(761,000)	15,322,000
Other	236,000	—	—	236,000
	<u>\$ 46,037,000</u>		<u>\$ (3,029,000)</u>	<u>\$ 43,008,000</u>

(1) Debt issuance costs are amortized over the term of the related debt facility.

(2) Although no borrowings were outstanding as of December 31, 2005, the amortization of the debt issuance cost is recorded to interest expense and subsequently capitalized as construction-in-progress during the construction period of the Sabine Pass LNG receiving terminal. For the year ended December 31, 2005, the amount amortized and capitalized was \$1,679,000.

(3) For the year ended December 31, 2005, the amount amortized to interest expense was \$589,000.

(4) For the year ended December 31, 2005, the amount amortized to interest expense was \$761,000.

Scheduled amortization of these debt issuance costs for each of the next five years is estimated at \$5,693,000.

**NOTE 8—INVESTMENT IN LIMITED PARTNERSHIP**

In August 2002, we entered into an agreement with entities controlled by Michael S. Smith, or Smith entities, to sell a 60% interest in the Freeport site and project. On February 27, 2003, we sold our interest in the site and project to Freeport LNG Development, L.P., or Freeport LNG, in which we held a 40% limited partner interest. Smith entities held the general partner interest and remaining 60% limited partner interest in Freeport LNG. We recovered \$1,740,000 in costs that we had incurred on the project and received an additional \$5,000,000 (\$2,500,000 during 2003 and \$2,500,000 in January 2004) from Freeport LNG. For the funding of Freeport LNG project development costs, Smith entities also committed to contribute up to \$9,000,000 and to allocate available proceeds from any sales of options or capacity reservations and/or proceeds from loans related to capacity reservations to these costs. In connection with the closing, we issued warrants to Smith entities to purchase 1,400,000 shares of our common stock at a price of \$1.25 per share, exercisable for a period of 10 years.

We accounted for the transfer of the site and planned LNG receiving terminal to Freeport LNG in accordance with Emerging Issues Task Force, or EITF, Issue No. 01-2, *Interpretations of APB Opinion No. 29*. Accordingly, in 2003 we recorded a \$4,760,000 gain on sale of LNG assets to the extent of the 60% interest not retained.

Effective March 1, 2003, we sold a 10% limited partner interest in Freeport LNG to an affiliate of Contango Oil & Gas Company, or Contango, for \$2,333,000 payable over time, including the cancellation of our \$750,000 short-term note payable. We also issued warrants to Contango to purchase 600,000 shares of our common stock at a price of \$1.25 per share, exercisable for a period of 10 years. As a result of the sale, we now hold a 30% limited partner interest in Freeport LNG. In December 2004, a subsidiary of The Dow Chemical Company, or Dow, acquired a 15% limited partner interest in Freeport LNG from one of the Smith entities, thereby reducing its limited partner interest from 60% to 45%.

**CHENIERE ENERGY, INC. AND SUBSIDIARIES**  
**NOTES TO CONSOLIDATED FINANCIAL STATEMENTS—(Continued)**

We account for our 30% limited partnership investment in Freeport LNG using the equity method of accounting. During 2003, we received installment payments totaling \$2,500,000 from Freeport LNG, which amounts were recorded as a reduction to the basis of our investment in the partnership. In addition, we recorded \$4,471,000 related to our 30% equity share of the 2003 net loss of Freeport LNG. This non-cash loss reduced the basis of our investment in Freeport LNG to zero, and as a result, we did not record \$278,000, or the 2003 Suspended Loss, of our equity share of the loss of the partnership as of December 31, 2003 because we did not guarantee any obligations of Freeport LNG and had not committed to provide additional financial support to Freeport LNG at that time.

In January 2004, we received the final \$2,500,000 payment from Freeport LNG. As our investment basis in Freeport LNG had been reduced to zero as of December 31, 2003, the payment was recorded as a reimbursement from limited partnership investment in our consolidated statement of operations.

During 2004, we recorded \$1,346,000 related to our 30% equity share of the 2004 net loss of Freeport LNG, including the 2003 Suspended Loss. This \$1,346,000 non-cash loss reduced our investment basis to zero and resulted in our recording accrued losses on investment in limited partnership of \$1,071,000 as of December 31, 2004. We accrued this liability, as we intended to provide additional financial support through the payment of outstanding capital call notices as of December 31, 2004. This additional financial support was provided in 2005 as a portion of the capital call payments discussed below.

During 2005, we paid \$2,102,000 of capital call contributions to Freeport LNG. In addition, we recognized an equity loss in the amount of \$1,031,000 relating to the net loss of Freeport LNG. Our total 30% equity share of the 2005 net loss of Freeport LNG was \$4,999,000 of which \$3,968,000 was suspended, or the 2005 Suspended Loss. In December 2005, Freeport LNG announced that it had closed a \$383,000,000 private placement of notes, which would be used to fund the remaining portion of the initial phase of the project, a portion of the cost of expanding the LNG receiving terminal and development of underground salt cavern gas storage. Accordingly, we do not currently have the obligation or intent to fund our suspended losses in the foreseeable future. As a result, as of December 31, 2005, the basis of our equity investment in Freeport LNG was zero, and we did not have any accrued losses.

The financial position of Freeport LNG at December 31, 2005 and 2004 and the results of Freeport LNG's operations for the years ended December 31, 2005, 2004 and 2003 are summarized as follows (in thousands):

	December 31,	
	2005	2004
Current assets	\$380,615	\$38,106
Construction-in-progress	246,351	9,728
Fixed assets, net, and other assets	9,309	592
<b>Total assets</b>	<b>\$636,275</b>	<b>\$48,426</b>
Current liabilities	\$ 53,533	\$ 5,676
Notes payable	595,766	48,041
Deferred revenue and other deferred credits	5,748	3,500
Partners' capital	(18,772)	(8,791)
<b>Total liabilities and partners' capital</b>	<b>\$636,275</b>	<b>\$48,426</b>

**CHENIERE ENERGY, INC. AND SUBSIDIARIES**  
**NOTES TO CONSOLIDATED FINANCIAL STATEMENTS—(Continued)**

	Year Ended December 31,		
	2005	2004	2003
Revenue	\$ —	\$10,000	\$ —
Loss from continuing operations	(16,238)	(3,569)	(14,940)
Net loss	(16,663)	(3,561)	(14,940)
Cheniere's equity in loss from limited partnership (adjusted for suspended losses)	\$ (1,031)	\$ (1,346)	\$ (4,471)

**NOTE 9—GOODWILL**

In February 2005, we acquired the minority interest of Corpus Christi LNG, L.P., or Corpus Christi LNG, through the acquisition of BPU LNG, Inc., or BPU, in exchange for 2,000,000 restricted shares of our common stock. BPU held as its sole asset the 33.3% limited partner interest in Corpus Christi LNG. As a result of this transaction, we now own 100% of the limited partner interest in Corpus Christi LNG. This transaction was accounted for using the purchase method of accounting as prescribed by SFAS No. 141, *Accounting for Business Combinations*, and was valued at \$77,246,000, including direct transaction costs. Of this amount, \$76,844,000 has been recorded as goodwill and will be accounted for in accordance with SFAS No. 142. The goodwill is the difference between the deemed value of the shares conveyed and the historical carrying value of the minority interest under generally accepted accounting principles plus direct transaction costs. For the calculation of federal income taxes, none of this goodwill amount will be deductible.

We performed an annual goodwill impairment review in the fourth quarter of 2005. A goodwill impairment review consists of comparing the carrying value, including goodwill, of the reporting unit under review, to the estimated fair value of the reporting unit. To the extent that the carrying value exceeds the estimated fair value of the reporting unit, an impairment of the reporting unit would occur resulting in an impairment charge to earnings. A reporting unit is defined as a business segment or component of a business segment that has similar economic characteristics. For our impairment review, we have designated our LNG receiving terminal business as the reporting unit under review due to similar economic characteristics. Our review indicated that no impairment of goodwill was necessary.

Because BPU's sole asset was the 33.3% limited partner interest in Corpus Christi LNG, which was consolidated in our financial statements, we do not believe that pro forma financial statements would provide any additional benefit to an investor in our common stock. As a result, we have not prepared pro forma financial statements related to the transaction.

**NOTE 10—DERIVATIVE INSTRUMENTS***Interest Rate Derivative Instruments*

In connection with the closing of the Sabine Pass Credit Facility in February 2005, Sabine Pass LNG entered into swap agreements, or the Sabine Swaps, with HSBC and Société Générale. Under the terms of the Sabine Swaps, Sabine Pass LNG will be able to hedge against rising interest rates, to a certain extent, with respect to its drawings under the Sabine Pass Credit Facility, up to a maximum amount of \$700,000,000. The Sabine Swaps have the effect of fixing the LIBOR component of the interest rate payable under the Sabine Pass Credit Facility with respect to hedged drawings under the Sabine Pass Credit Facility up to a maximum of \$700,000,000 at 4.49% from July 25, 2005 through March 25, 2009 and at 4.98% from March 26, 2009 through March 25, 2012. The final termination date of the Sabine Swaps will be March 25, 2012.

**CHENIERE ENERGY, INC. AND SUBSIDIARIES**  
**NOTES TO CONSOLIDATED FINANCIAL STATEMENTS—(Continued)**

In connection with the closing of the Term Loan on August 31, 2005, Cheniere LNG Holdings entered into interest rate swap agreements with Credit Suisse, or the Term Loan Swaps, to hedge against rising interest rates. Under the terms of the Term Loan Swaps, Cheniere LNG Holdings hedged an initial notional amount of \$600,000,000. The notional amount declines in accordance with anticipated principal payments under the Term Loan. The Term Loan Swaps have the effect of fixing the LIBOR rate component of the interest rate payable under the Term Loan at 3.75% from August 31, 2005 to September 27, 2007, at 3.98% from September 28, 2007 to September 27, 2008, and at 5.98% from September 28, 2008 to September 30, 2010. The final termination date of the Term Loan Swaps will be September 30, 2010.

*Accounting for Hedges*

SFAS No. 133, as amended and interpreted by other related accounting literature, establishes accounting and reporting standards for derivative instruments. Under SFAS No. 133, we are required to record derivatives on our balance sheet as either an asset or liability measured at their fair value, unless exempted from derivative treatment under the normal purchase and normal sale exception. Changes in the fair value of derivatives are recognized currently in earnings unless specific hedge criteria are met. These criteria require that the derivative is determined to be effective as a hedge and that it is formally documented and designated as a hedge.

We have determined that the Sabine Swaps and the Term Loan Swaps, or collectively, the Swaps, qualify as cash flow hedges within the meaning of SFAS No. 133 and have designated them as such. At their inception, we determined the hedging relationship of the Swaps and the underlying debt to be highly effective. We will continue to assess the hedge effectiveness of the Swaps on a quarterly basis in accordance with the provisions of SFAS No. 133.

SFAS No. 133 provides that the effective portion of the gain or loss on a derivative instrument designated and qualifying as a cash flow hedging instrument be reported as a component of other comprehensive income, or OCI, and be reclassified into earnings in the same period during which the hedged forecasted transaction affects earnings. In our case, the impact on earnings is reflected in interest expense. The ineffective portion of the gain or loss on the derivative instrument, if any, must be recognized currently in earnings. For the year ended December 31, 2005, we have recognized net derivative gains of \$837,000 into earnings. If the forecasted transaction is no longer probable of occurring, the associated gain or loss recorded in OCI is recognized currently in earnings.

*Summary of Derivative Values*

The following table reflects the amounts that are recorded as assets and liabilities at December 31, 2005 for our derivative instruments (in thousands):

	<b>Interest Rate Derivative Instruments</b>
Current derivative assets	\$ 5,468
Derivative receivables (1)	1,175
Long-term derivative assets	1,837
	<hr/>
Total derivative assets	8,480
	<hr/>
Current derivative liabilities	—
Derivative payables (2)	84
Long-term derivative liabilities	1,682
	<hr/>
Total derivative liabilities	1,766
	<hr/>
Net derivative assets	\$ 6,714

(1) Included in Accounts Receivable on the Consolidated Balance Sheet.

(2) Included in Accrued Liabilities on the Consolidated Balance Sheet.

**CHENIERE ENERGY, INC. AND SUBSIDIARIES**  
**NOTES TO CONSOLIDATED FINANCIAL STATEMENTS—(Continued)**

Below is a reconciliation of our net derivative assets to our accumulated other comprehensive income at December 31, 2005 (in thousands):

Net derivative assets	\$ 6,714
Net derivative gains recognized into earnings	(837)
Other comprehensive income reclassified to interest expense	(15)
Cash settled derivative losses during the period	(19)
	<hr/>
Accumulated other comprehensive income, before income taxes	5,843
Income taxes on accumulated other comprehensive income	(2,045)
	<hr/>
Accumulated other comprehensive income, after income taxes	<u>\$ 3,798</u>

For the year ended December 31, 2005, we settled derivative contracts that resulted in \$391,000 of net realized derivative gains. The maximum length of time over which we have hedged our exposure to the variability in future cash flows for forecasted transactions is seven years under the Swaps. As of December 31, 2005, \$6,259,000 of accumulated net deferred gains on the Swaps, currently included in other comprehensive income, are expected to be reclassified to earnings during the next twelve months, assuming no change in the LIBOR forward curves at December 31, 2005. The actual amounts that will be reclassified will likely vary based on the probability that interest rates will, in fact, change. Therefore, management is unable to predict what the actual reclassification from OCI to earnings (positive or negative) will be for the next twelve months.

**NOTE 11—ACCRUED LIABILITIES**

Accrued liabilities consist of the following (in thousands):

	December 31,	
	2005	2004
LNG terminal construction costs	\$ 39,728	\$ —
Accrued interest expense and related fees	4,937	—
Debt issuance costs	3,083	—
Payroll	2,460	—
LNG terminal development expenses	1,534	1,611
Professional and legal services	1,043	342
Insurance expense	41	488
Other accrued liabilities	1,718	755
	<hr/>	<hr/>
Accrued liabilities	<u>\$ 54,544</u>	<u>\$ 3,196</u>

**NOTE 12—DEFERRED REVENUE**

In December 2003, we entered into a shareholders agreement whereby we became a minority owner of J & S Cheniere S.A., a Switzerland joint-stock company, or J & S Cheniere. The majority owner is J & S Energy Holding B.V., or J & S Holding, a Netherlands corporation affiliated with J & S Trading Company, Ltd., an international petroleum trading and marketing company. J & S Cheniere was formed for the purpose of buying, selling, transporting and trading LNG. Pursuant to the shareholders agreement, we identify and assist with LNG-related business opportunities that we determine are appropriate for J & S Cheniere. We are not required to offer any particular business opportunities or funding to J & S Cheniere. We have no board of director

**CHENIERE ENERGY, INC. AND SUBSIDIARIES**  
**NOTES TO CONSOLIDATED FINANCIAL STATEMENTS—(Continued)**

representation nor do we participate in the day-to-day management of J & S Cheniere. All financing of the business opportunities will be provided by J & S Holding should it determine that a business opportunity is appropriate for J & S Cheniere. However, J & S Holding is not required to fund any particular business opportunity. We account for this investment using the cost method of accounting. At December 31, 2005, Cheniere's investment basis was \$16,000.

Also in December 2003, we entered into an option agreement with J & S Cheniere under which J & S Cheniere has an option to enter into a TUA reserving up to 200 MMcf/d of capacity at each of our Sabine Pass and Corpus Christi LNG facilities. We were paid \$1,000,000 in January 2004 following execution of the option agreement by J & S Cheniere in January 2004. The terms of the TUA contemplated by the J & S Cheniere option agreement have not been negotiated or finalized. We anticipate that definitive arrangements with J & S Cheniere may involve different terms and transaction structures than were contemplated when the option agreement was entered into in December 2003. Although non-refundable, we have recorded the option fee as deferred revenue.

In November 2004, Total LNG USA, Inc., or Total, paid Sabine Pass LNG a nonrefundable advance capacity reservation fee of \$10,000,000 in connection with the reservation of approximately 1.0 Bcf/d of LNG regasification capacity at the Sabine Pass LNG receiving terminal. An additional advance capacity reservation fee payment of \$10,000,000 was paid by Total to Sabine Pass LNG in April 2005. The advance capacity reservation fee payments will be amortized over a 10-year period after operations commence as a reduction of Total's regasification capacity fee under its TUA. As a result, we record the advance capacity reservation payments that we receive, although non-refundable, as deferred revenue to be amortized to income over the corresponding 10-year period.

Also in November 2004, we entered into a TUA to provide Chevron USA, Inc., or Chevron USA, with approximately 700 MMcf/d of LNG regasification capacity at our Sabine Pass LNG receiving terminal. In December 2005, Chevron USA exercised its option to increase its reserved capacity by approximately 300 MMcf/d to approximately 1.0 Bcf/d and paid Sabine Pass LNG an additional \$3,000,000 advance capacity reservation fee. As of December 31, 2005, Chevron USA has made advance capacity reservation fee payments to Sabine Pass LNG totaling \$20,000,000, with \$12,000,000 paid in 2004 and \$8,000,000 paid in 2005. These capacity reservation fee payments will be amortized over a 10-year period as a reduction of Chevron USA's regasification capacity fee under the TUA. As a result, we record the advance capacity reservation payments that we receive, although non-refundable, as deferred revenue to be amortized to income over the corresponding 10-year period.

As of December 31, 2005 and 2004, we had recorded \$41,000,000 and \$23,000,000, respectively, as deferred revenue related to option and advance capacity reservation fee payments.

**NOTE 13—MINORITY INTEREST IN LIMITED PARTNERSHIP**

In May 2003, we formed a limited partnership, Corpus Christi LNG, L.P., or Corpus Christi LNG, to develop an LNG receiving terminal near Corpus Christi, Texas. Under the terms of the limited partnership agreement, we contributed our technical expertise and know-how, and all of the work in progress related to the Corpus Christi project, in exchange for a 66.7% limited partner interest in Corpus Christi LNG.

Substantially all Corpus Christi LNG expenditures incurred through March 31, 2004 were the obligation of the minority owner, since the minority owner was required to fund 100% of the first \$4,500,000 of partnership expenditures. Because partnership expenditures had reached \$4,500,000 as of March 31, 2004, the minority owner began sharing all subsequent expenditures based on its 33.3% limited partner interest.



**CHENIERE ENERGY, INC. AND SUBSIDIARIES**  
**NOTES TO CONSOLIDATED FINANCIAL STATEMENTS—(Continued)**

In February 2005, we acquired the minority interest of Corpus Christi LNG through the acquisition of BPU. As a result of this transaction, we now own 100% of the limited partner interest of Corpus Christi LNG and are required to fund 100% of expenditures incurred after such date. We also manage the project as the general partner through one of our wholly-owned subsidiaries.

For the years ended December 31, 2005, 2004 and 2003, our consolidated statement of operations includes \$97,000, \$2,862,000 and \$3,015,000, respectively, related to the minority interest of Corpus Christi LNG.

**NOTE 14—LONG-TERM DEBT**

As of December 31, 2005 and 2004, our long-term debt is comprised of the following (in thousands):

	December 31,	
	2005	2004
Sabine Pass Credit Facility	\$ —	\$—
Convertible Senior Unsecured Notes	325,000	—
Term Loan	598,500	—
	<u>923,500</u>	<u>—</u>
Less: Current Portion—Term Loan	(6,000)	—
<b>Total Long-Term Debt</b>	<b>\$917,500</b>	<b>\$—</b>

Below is a schedule of future principal payments that we are obligated to make based on our outstanding long-term debt at December 31, 2005 (in thousands):

	Payments Due for Years Ended December 31,						
	Total	2006	2007	2008	2009	2010	
Term Loan	\$ 598,500	\$ 6,000	\$ 6,000	\$ 6,000	\$ 6,000	\$ 6,000	\$ 568,500
Convertible Senior Unsecured Notes	325,000	—	—	—	—	—	325,000
<b>Total</b>	<b>\$ 923,500</b>	<b>\$ 6,000</b>	<b>\$ 6,000</b>	<b>\$ 6,000</b>	<b>\$ 6,000</b>	<b>\$ 6,000</b>	<b>\$ 893,500</b>

*Sabine Pass Credit Facility*

In February 2005, Sabine Pass LNG entered into the \$822,000,000 Sabine Pass Credit Facility with an initial syndicate of 47 financial institutions. Société Générale serves as the administrative agent and HSBC serves as collateral agent. The Sabine Pass Credit Facility will be used to fund a substantial majority of the costs of constructing and placing into operation Phase 1 of our Sabine Pass LNG receiving terminal. Unless Sabine Pass LNG decides to terminate availability earlier, the Sabine Pass Credit Facility will be available until no later than April 1, 2009, after which time any unutilized portion of the Sabine Pass Credit Facility will be permanently canceled. Before Sabine Pass LNG could make an initial borrowing under the Sabine Pass Credit Facility, it was required to provide evidence that it had received equity contributions in an amount sufficient to fund \$233,715,000 of the project costs. As of December 31, 2005, the \$233,715,000 in equity contributions had been funded. At December 31, 2005, there were no borrowings outstanding; however, as of February 28, 2006, \$58,500,000 had been drawn under the Sabine Pass Credit Facility.

Borrowings under the Sabine Pass Credit Facility bear interest at a variable rate equal to LIBOR plus the applicable margin. The applicable margin varies from 1.25% to 1.625% during the term of the Sabine Pass Credit Facility. The Sabine Pass Credit Facility provides for a commitment fee of 0.50% per annum on the daily

**CHENIERE ENERGY, INC. AND SUBSIDIARIES**  
**NOTES TO CONSOLIDATED FINANCIAL STATEMENTS—(Continued)**

committed, undrawn portion of the facility. Annual administrative fees must also be paid to the administrative and collateral agents. The principal of loans made under the Sabine Pass Credit Facility must be repaid in semi-annual installments commencing six months after the later of (i) the date that substantial completion of the project occurs under the EPC agreement and (ii) the commercial start date under the Total TUA. Sabine Pass LNG may specify an earlier date to commence repayment upon satisfaction of certain conditions. In any event, payments under the Sabine Pass Credit Facility must commence no later than October 1, 2009, and all obligations under the Sabine Pass Credit Facility mature and must be fully repaid by February 25, 2015.

The Sabine Pass Credit Facility contains customary conditions precedent to the initial borrowing and any subsequent borrowings, as well as customary affirmative and negative covenants. We were in compliance, in all material respects, with these covenants at December 31, 2005. Sabine Pass LNG has obtained, and may in the future seek, consents, waivers and amendments to the Sabine Pass Credit Facility documents. The obligations of Sabine Pass LNG under the Sabine Pass Credit Facility are secured by all of Sabine Pass LNG's personal property, including the Total and Chevron USA TUAs and the partnership interests in Sabine Pass LNG.

In connection with the closing of the Sabine Pass Credit Facility, Sabine Pass LNG entered into the Sabine Swaps with HSBC and Société Générale. Under the terms of the Sabine Swaps, Sabine Pass LNG will be able to hedge against rising interest rates, to a certain extent, with respect to its drawings under the Sabine Pass Credit Facility, up to a maximum amount of \$700,000,000. The Sabine Swaps have the effect of fixing the LIBOR component of the interest rate payable under the Sabine Pass Credit Facility with respect to hedged drawings under the Sabine Pass Credit Facility, up to a maximum of \$700,000,000 at 4.49% from July 25, 2005 to March 25, 2009, and at 4.98% from March 26, 2009 through March 25, 2012. The final termination date of the Sabine Swaps will be March 25, 2012.

During the construction period, all interest costs, including amortization of related debt issuance costs and commitment fees, will be capitalized as part of the total cost of Phase 1 of our Sabine Pass LNG receiving terminal. As of December 31, 2005, \$5,323,000 in commitment fees and amortization of debt issuance costs have been capitalized and included in LNG terminal construction-in-progress.

*Convertible Senior Unsecured Notes*

In July 2005, we consummated a private offering of \$325,000,000 aggregate principal amount of Convertible Senior Unsecured Notes due August 1, 2012 to qualified institutional buyers pursuant to Rule 144A under the Securities Act. The notes bear interest at a rate of 2.25% per year. The notes are convertible into our common stock pursuant to the terms of the indenture governing the notes at an initial conversion rate of 28.2326 per \$1,000 principal amount of the notes, which is equal to a conversion price of approximately \$35.42 per share. We may redeem some or all of the notes on or before August 1, 2012, for cash equal to 100% of the principal plus any accrued and unpaid interest if in the previous 10 trading days the volume-weighted average price of our common stock exceeds \$53.13, subject to adjustment, for at least five consecutive trading days. In the event of such a redemption, we will make an additional payment equal to the present value of all remaining scheduled interest payments through August 1, 2012, discounted at the U.S. Treasury rate plus 50 basis points. The indenture governing the notes contains customary reporting requirements.

Concurrent with the issuance of the Convertible Senior Unsecured Notes, we also entered into hedge transactions in the form of an issuer call spread (consisting of a purchase and a sale of call options on our common stock) with an affiliate of the initial purchaser of the notes, having a term of two years, and a net cost to us of \$75,703,000. These hedge transactions are expected to offset potential dilution from conversion of the notes up to a market price of \$70.00 per share. The net cost of the hedge transactions is recorded as a reduction to Additional Paid-in-Capital in accordance with the guidance of the Emerging Issues Task Force, or EITF, Issue

**CHENIERE ENERGY, INC. AND SUBSIDIARIES**  
**NOTES TO CONSOLIDATED FINANCIAL STATEMENTS—(Continued)**

00-19, *Accounting for Derivative Financial Instruments Indexed to, and Potentially Settled in, a Company's Own Stock* Net proceeds from the offering were \$239,786,000, after deducting the cost of the hedge transactions, the underwriting discount and related fees. As of December 31, 2005, no holders had elected to convert their notes. Total interest expense recognized for the year ended December 31, 2005 was \$3,741,000 before interest capitalization of \$170,000.

*Term Loan*

In August 2005, Cheniere LNG Holdings entered into the \$600,000,000 Term Loan with Credit Suisse. The Term Loan interest rate equals LIBOR plus a 2.75% margin and terminates on August 30, 2012. In connection with the closing, Cheniere LNG Holdings entered into the Term Loan Swaps with Credit Suisse to hedge the LIBOR interest rate component of the Term Loan. The blended rate of the Term Loan Swaps on the Term Loan results in an annual fixed interest rate of 7.25% (including the 2.75% margin) for the first five years (See Note 10—"Derivative Instruments"). On December 30, 2005, Cheniere LNG Holdings made the first required quarterly principal payment of \$1,500,000. Quarterly principal payments of \$1,500,000 are required through June 30, 2012, and a final principal payment of \$559,500,000 is required on August 30, 2012. As discussed in Note 3—"Restricted Cash and Cash Equivalents", a portion of the loan proceeds is controlled by Credit Suisse and is restricted to its use.

At December 31, 2005, principal repayments on the Term Loan of \$6,000,000 are due within the next 12 months and are classified on the balance sheet as a current liability on the Term Loan. Interest expense for the year ended December 31, 2005 was \$14,405,000 before interest capitalization of \$603,000. The Term Loan contains customary affirmative and negative covenants. We were in compliance, in all material respects, with these covenants at December 31, 2005. The obligations of Cheniere LNG Holdings are secured by its 100% equity interest in Sabine Pass LNG and its 30% limited partner equity interest in Freeport LNG.

*Note Payable*

In January 2004, we repaid the \$1,000,000 outstanding balance under a line of credit with a commercial bank. The line of credit was terminated in June 2004.

**NOTE 15—FINANCIAL INSTRUMENTS**

The estimated fair value of financial instruments is the amount at which the instrument could be exchanged currently between willing parties. The carrying amounts reported in the consolidated balance sheet for cash and cash equivalents, restricted cash and cash equivalents, accounts receivable and accounts payable approximate fair value due to their short-term nature. We use available marketing data and valuation methodologies to estimate the fair value of debt. This disclosure is presented in accordance with SFAS No. 107, *Disclosures about Fair Value of Financial Instruments* and does not impact our financial position, results of operations or cash flows.

Long-Term Debt (in thousands):

	December 31, 2005	
	Carrying Amount	Estimated Fair Value
Term Loan due 2012 (1)	\$ 598,500	\$ 598,500
2.25% Convertible Senior Unsecured Notes due 2012 (2)	325,000	392,031
Sabine Pass Credit Facility (3)	—	—
	<u>\$ 923,500</u>	<u>\$ 990,531</u>

**CHENIERE ENERGY, INC. AND SUBSIDIARIES**  
**NOTES TO CONSOLIDATED FINANCIAL STATEMENTS—(Continued)**

- (1) The Term Loan bears interest based on a floating rate; therefore, the estimated fair value is deemed to equal the carrying amount of these notes.
- (2) The fair value of our Convertible Senior Unsecured Notes is based on a closing trading price as of December 30, 2005.
- (3) The Sabine Pass Credit Facility will bear interest based on a floating rate. No debt was outstanding under this facility at December 31, 2005.

**NOTE 16—INCOME TAXES**

From our inception, we have reported net operating losses for both financial reporting purposes and for federal and state income tax reporting purposes. Accordingly, we are not presently a taxpayer and have not recorded a net liability for federal or state income taxes in any of the years included in the accompanying financial statements. Our consolidated statement of operations for the years ended December 31, 2005, 2004 and 2003 includes deferred income tax benefits of \$2,045,000, \$-0- and \$-0-, respectively. The deferred income tax benefit recorded for the year ended December 31, 2005 has been provided for in accordance with the guidance in paragraph 140 of SFAS No. 109 and EITF Abstracts, Topic D-32 which, in certain circumstances, requires items reported in OCI to be considered in the determination of the amount of tax benefit when a net operating loss occurs. In our situation, the specific circumstance relates to OCI of \$5,843,000 recorded as of December 31, 2005 related to our interest rate swaps (See Note 10—“Derivative Instruments” and Note 19—“Other Comprehensive Loss” for additional discussions). The deferred tax benefit included in our 2005 consolidated statement of operations represents the portion of the change in our tax asset valuation account that is allocable to the deferred income tax on items reported in other comprehensive income in our 2005 consolidated statement of stockholders’ equity.

Income tax expense (benefit) included in our reported net loss consists of the following (in thousands):

	Year Ended December 31,		
	2005	2004	2003
Current federal income tax expense	\$ —	\$ —	\$ —
Deferred federal income tax benefit	2,045	—	—
Total income tax benefit.	\$2,045	\$ —	\$ —

Deferred tax assets and liabilities reflect the net tax effect of temporary differences between the carrying amount of assets and liabilities for financial reporting purposes and amounts used for income tax purposes. Significant components of our deferred tax assets and liabilities at December 31, 2005 and 2004 are as follows (in thousands):

	December 31,	
	2005	2004
Deferred tax assets		
NOL carryforwards	\$ 19,310	\$ 16,944
Advance payments—terminal use agreements	14,000	8,140
Start-up costs and construction-in-progress associated with LNG projects	11,594	6,223
Investment in limited partnership	1,755	1,250
Investment in unconsolidated affiliate	—	1,553
	46,659	34,110

**CHENIERE ENERGY, INC. AND SUBSIDIARIES**  
**NOTES TO CONSOLIDATED FINANCIAL STATEMENTS—(Continued)**

	December 31,	
	2005	2004
Deferred tax liabilities		
Oil and gas properties and fixed assets	4,099	4,828
Stock grant compensation expense	270	237
Unrealized gain on hedging transactions	1,968	—
	6,337	5,065
Net deferred tax assets	40,322	29,045
Less: tax asset valuation allowance	(40,322)	(29,045)
	\$ —	\$ —

The change in the deferred tax asset valuation allowance was \$11,277,000 and \$17,475,000 during the years ended December 31, 2005 and 2004, respectively.

At December 31, 2005, we had net operating loss, or NOL, carryforwards for federal income tax reporting purposes of approximately \$55,172,000. In accordance with SFAS No. 109, a valuation allowance equal to our net deferred tax asset balance has been established due to the uncertainty of realizing the tax benefits related to our NOL carryforwards and other deferred tax assets.

NOL carryforwards expire starting in 2012 extending through 2025. Certain of our NOLs which were previously subject to annual utilization limitations under the Internal Revenue Code Section 382 change of ownership regulations are now available for utilization due to annual increases in the allowed NOL utilization amounts provided for in Section 382. The NOL carryforward amounts presented in the table above include approximately \$11,664,000 and \$8,323,000 for the years ended December 31, 2005 and 2004, respectively, of excess tax benefits related to the exercise of non-qualified employee stock options and vested stock awards. The full amount of the related tax benefit is included in our deferred tax asset valuation allowance.

The reconciliation of the federal statutory income tax rate to our effective income tax rate follows:

	Year Ended December 31,		
	2005	2004	2003
U.S. statutory tax rate	35 %	35 %	35 %
Excess tax benefits related to exercise of non-qualified employee stock options and vested stock awards (1)	12 %	37 %	12 %
Deferred tax asset valuation reserve (2)	(36)%	(69)%	(51)%
State income tax expense (net of federal benefit) (3)	(5)%	2 %	2 %
All other	0 %	(5)%	2 %
	6 %	0 %	0 %
Effective tax rate as reported	6 %	0 %	0 %

(1) As of December 31, 2005, we have elected to account for stock-based compensation in accordance with APB Opinion No. 25 (see Note 2—"Summary of Significant Accounting Policies—Stock-Based Compensation"). For federal income tax reporting purposes, we are generally allowed to claim federal income tax deductions based on the fair market value of the underlying securities on the vest date for vested stock awards and on the date of exercise for stock options. Because the stock-based compensation expense that is required to be included in our reported annual operating losses is significantly less than the amounts

**CHENIERE ENERGY, INC. AND SUBSIDIARIES**  
**NOTES TO CONSOLIDATED FINANCIAL STATEMENTS—(Continued)**

that have been included in our employees' taxable incomes, the associated excess tax benefits reduce our reported effective tax rates. As discussed above, to date, approximately \$11,664,000 of deferred excess tax benefits related to the exercise of non-qualified employee stock options and vested stock awards are included in our NOL carryforward amount.

- (2) As discussed above, in accordance with SFAS No. 109, a valuation allowance equal to our net deferred tax asset balance has been established due to the uncertainty of realizing the federal and state deferred tax benefits related to our NOL carryforwards and other deferred tax assets.
- (3) SFAS No. 109 requires us to measure our deferred income tax assets and liabilities separately for each tax jurisdiction that imposes an income tax on our operations (principally federal and state income taxes). In prior reporting periods, our reported effective tax rate included an additional 2% for certain deferred state income tax benefits related to our Texas and Louisiana exploration and development operations. We are not expecting to realize such state income tax benefits; therefore, our 2005 reported effective tax rate includes an adjustment to eliminate the related deferred state income tax benefits.

**NOTE 17—WARRANTS**

As of December 31, 2005, there were no outstanding warrants for the purchase of our common stock. Warrants we issued did not confer upon the holders thereof any voting or other rights of a stockholder of Cheniere. Warrants were granted in connection with certain of our debt or equity financings and as compensation for services. In instances where warrants were granted in connection with financings, such warrants were valued based on the estimated fair market value of the stock at the date of issuance. Where warrants were issued for services, fair value was calculated using the Black-Scholes pricing model. Information related to our warrants is summarized in the following table:

	Year Ended December 31,		
	2005	2004	2003
Outstanding at beginning of period	533,334	2,599,166	5,187,042
Warrants issued	—	—	3,432,500
Warrants exercised	(530,234)	(2,043,844)	(2,164,186)
Warrants canceled	(3,100)	(21,988)	(3,856,190)
Outstanding at end of period	—	533,334	2,599,166
Weighted average exercise price of warrants outstanding	\$ —	\$ 1.21	\$ 1.65
Weighted average remaining contractual life of warrants outstanding	N/A	6.0 years	5.5 years

In September 2005, we issued 96,900 shares of common stock in exchange for the surrender of warrants to purchase 100,000 shares of common stock in a cashless transaction based on the then-current market price of \$40.33. The warrants were exercisable at \$1.25 per share.

In separate cashless transactions, in October 2004, we issued 57,724 and 57,366 shares of common stock in exchange for the surrender of warrants to purchase 62,500 and 62,500 shares of common stock based on the then-current price of \$11.45 and \$10.65 per share, respectively. The warrants were exercisable at \$0.875 per share.

In August 2004, we issued 112,922 shares of common stock in exchange for the surrender of warrants to purchase 125,000 shares in a cashless transaction based on the then-current market price of \$9.055 per share. The warrants were exercisable at \$0.875 per share.

**CHENIERE ENERGY, INC. AND SUBSIDIARIES**  
**NOTES TO CONSOLIDATED FINANCIAL STATEMENTS—(Continued)**

In August 2003, we issued 756,616 shares of common stock in exchange for the surrender of warrants to purchase 1,400,000 shares in a cashless transaction based on the then-current market price of \$2.72 per share. The warrants were exercisable at \$1.25 per share.

In April 2003, we issued warrants to purchase 500,000 shares of common stock at \$1.25 per share to our Chief Executive Officer as a signing bonus. At the time of issue, the current market price was \$0.90 per share. The warrants vested one year from the date of issue and were exercised in September 2004.

In February 2003, in connection with the sale of a 60% interest in our Freeport LNG project, we issued warrants valued at \$540,000 to purchase 1,400,000 shares of our common stock. We also issued warrants to purchase 482,500 shares of common stock to a former employee of Cheniere and the current President and Chief Operating Officer of Freeport LNG, in replacement of his options to purchase 482,500 shares of common stock. The number and exercise prices of the warrants were the same as the options replaced and ranged from \$0.53 to \$6.00 per share. Warrants to purchase 450,000 shares of common stock and valued at \$174,000 were issued to LNG consultants for services previously performed. In connection with the sale of a 10% interest in the limited partnership, we issued warrants valued at \$242,000 to purchase 600,000 shares of common stock to the purchaser.

**NOTE 18—EMPLOYEE BENEFITS**

*Stock-Based Compensation*

In 1997, we established the Cheniere Energy, Inc. 1997 Stock Option Plan, as amended, or the Option Plan, which allowed for the issuance of options to purchase up to 5,000,000 shares of our common stock. Options on 5,000,000 shares of our common stock had been granted and were outstanding or had been exercised as of December 31, 2005. The term of options granted under the Option Plan is generally five years. Vesting varies, but generally occurs over three or four years, in increments of 33% or 25%, respectively, on each anniversary of the grant date. All options granted under the Option Plan have exercise prices equal to or greater than fair market value at the date of grant.

In 2004, our stockholders approved the Cheniere Energy, Inc. 2003 Stock Incentive Plan, as amended, or the 2003 Stock Incentive Plan, which allowed for the issuance of non-qualified or incentive stock options, purchased stock, stock (bonus stock), non-vested (restricted) stock, stock appreciation rights, phantom stock and other stock-based performance awards. It initially authorized the issuance of options to purchase common stock or awards of common stock up to 2,000,000 shares. On February 8, 2005, the shareholders approved an amendment to the 2003 Stock Incentive Plan increasing the number of shares of common stock authorized for issuance under the plan from 2,000,000 to 8,000,000. Through December 31, 2005, a total of 5,335,771 shares have been issued or reserved for issuance under the 2003 Stock Incentive Plan.

In 2004, stock grants of 322,000 shares, non-vested stock grants of 680,352 shares, and non-qualified stock option grants of 735,000 shares (net of forfeitures) were made to employees and directors from the 2003 Stock Incentive Plan. In February 2004, we issued stock and non-vested stock under the 2003 Stock Incentive Plan related to our performance in 2003. This included \$2,415,000 of non-cash compensation expense related to the issuance of 322,000 shares, which shares were fully vested on the date of grant; and \$3,330,000 of deferred compensation as a reduction to stockholders' equity, related to the issuance of 444,000 shares of non-vested stock, which vests on each of the first and second anniversaries of the grant date. In November 2004, we recorded \$4,946,000 of deferred compensation as a reduction to stockholders' equity related to 236,352 shares of non-vested stock that were issued to employees and directors related to our performance in 2004. One-third of the shares vest on each of the first, second and third anniversaries of the grant date. The non-qualified stock option grants of 735,000 shares were made to new employees throughout the course of 2004.

**CHENIERE ENERGY, INC. AND SUBSIDIARIES**  
**NOTES TO CONSOLIDATED FINANCIAL STATEMENTS—(Continued)**

In 2005, non-vested stock and non-qualified stock option grants of 175,151 and 3,423,296 shares (net of forfeitures), respectively, were made to employees and directors from the 2003 Stock Incentive Plan. In March 2005, non-qualified stock option grants to purchase 2,200,000 shares of common stock, or Retention Grants, were made to certain executive officers and key employees to provide an incentive for them to remain employed while the company executes critical aspects of its business plan. The Retention Grants have exercise prices at or significantly above the market price on the date of issuance and vest in one-third increments in March 2009, 2010 and 2011. In December 2005, we recorded \$6,166,000 of deferred compensation as a reduction to stockholders' equity for the issuance of 160,151 shares of non-vested stock to employees and directors related to our performance in 2005. One-third of the shares vest on each of the first, second and third anniversaries of the grant date. Also in 2005, we recorded \$498,000 of deferred compensation as a reduction of stockholders' equity in connection 15,000 shares of non-vested stock issued to employees. One-fourth of the shares vest on each of the first, second, third and fourth anniversaries of the effective dates. Non-qualified stock options for the purchase of 1,223,296 shares of common stock (net of forfeitures) were granted to new employees throughout 2005 and have exercise prices equal to fair market value at the date of grant. One-fourth of the option shares vest on each of the first, second, third and fourth anniversaries of the grant date.

Deferred compensation related to non-vested stock grants is amortized on a straight-line basis over the vesting period. During 2004, we recorded \$4,148,000 (before capitalization of \$529,000 as oil and gas property costs) in non-cash compensation expense, of which \$2,415,000 related to stock awards and \$1,733,000 related to amortization of deferred compensation associated with non-vested stock awards. During 2005, we recorded \$3,522,000 (before capitalization of \$145,000 as oil and gas property costs) in total non-cash compensation expense related to amortization of deferred compensation associated with non-vested stock awards. At December 31, 2005, the balance of non-cash deferred compensation remaining to be amortized was \$9,684,000.

A summary of the status of our stock options is presented below:

	Year Ended December 31,		
	2005	2004	2003
Options outstanding at beginning of period	2,599,264	3,920,000	3,967,222
Options granted at an exercise price of \$0.46 to \$2.31 per share	—	—	980,000
Options granted at an exercise price of \$7.40 to \$11.26 per share	—	1,380,000	—
Options granted at an exercise price of \$26.51 to 29.94 per share	699,800	—	—
Options granted at an exercise price of \$30.00 to \$36.60 per share	1,942,296	110,000	—
Options granted at an exercise price of \$37.05 to \$42.73 per share	320,700	—	—
Options granted at an exercise price of \$60.00 per share	400,000	—	—
Options granted at an exercise price of \$90.00 per share	100,000	—	—
Options exercised	(897,164)	(2,696,012)	(375,000)
Options converted to warrants	—	—	(482,500)
Options surrendered in cashless exercises, cancelled, or expired	(40,084)	(114,724)	(169,722)
<b>Options outstanding at end of period</b>	<b>5,124,812</b>	<b>2,599,264</b>	<b>3,920,000</b>
<b>Options exercisable at end of period</b>	<b>486,559</b>	<b>444,266</b>	<b>2,323,960</b>
Weighted average exercise price of options outstanding	\$ 28.67	\$ 5.94	\$ 1.11
Weighted average exercise price of options exercisable	\$ 7.43	\$ 1.98	\$ 1.25
Weighted average fair value of options granted during the period	\$ 20.16	\$ 5.81	\$ 0.80
Weighted average remaining contractual life of options outstanding	7.1 years	3.7 years	2.9 years



[Table of Contents](#)

**CHENIERE ENERGY, INC. AND SUBSIDIARIES**  
**NOTES TO CONSOLIDATED FINANCIAL STATEMENTS—(Continued)**

The following table summarizes information about fixed options outstanding at December 31, 2005:

<u>Exercise Prices</u>	<u>Options Outstanding</u>		<u>Options Exercisable</u>
	<u>Number Outstanding</u>	<u>Weighted Average Years Remaining Contractual Life</u>	<u>Number Outstanding</u>
\$ 0.46 to \$2.31 per share	465,660	2.3	198,997
\$ 7.40 to \$11.26 per share	1,125,856	3.2	245,894
\$26.51 to \$29.94 per share	695,800	9.3	—
\$30.00 to \$36.60 per share	2,030,796	8.8	36,668
\$37.05 to \$42.73 per share	306,700	9.2	5,000
\$60.00 per share	400,000	9.2	—
\$90.00 per share	100,000	9.2	—
	<u>5,124,812</u>	<u>7.1</u>	<u>486,559</u>

*401(k) Plan*

In 2005, we established a defined contribution pension plan, or the 401(k) Plan. The 401(k) Plan allows eligible employees to contribute up to 100% of their compensation up to the Internal Revenues Service maximum. We match each employee's salary deferrals (contributions) up to six percent of compensation and may make additional contributions at our discretion. Our contributions to the 401(k) Plan were \$517,000 for the year ended December 31, 2005. No discretionary contributions were made by us to the 401(k) Plan in 2005.

**NOTE 19—OTHER COMPREHENSIVE LOSS**

The following table is a reconciliation of our Net Loss to our Comprehensive Loss for the periods shown (in thousands):

	<u>Year Ended December 31,</u>		
	<u>2005</u>	<u>2004</u>	<u>2003</u>
Net Loss	\$(29,798)	\$(24,568)	\$(5,288)
Other Comprehensive Income items:			
Cash Flow Hedges, net of income taxes	3,798	—	—
Comprehensive Loss	<u>\$(26,000)</u>	<u>\$(24,568)</u>	<u>\$(5,288)</u>

**NOTE 20—RELATED PARTY TRANSACTIONS**

From time to time, officers and employees may charter aircraft for company business travel. We entered into a letter agreement, or charter letter, with an unrelated third-party entity, Western Airways, Inc., or Western, that specifies the terms under which it would provide for charter of a Challenger 600 aircraft. One of the Challenger 600 aircraft which may be provided by Western for such services is owned by Bramblebush, LLC, or the LLC. The LLC is owned and/or controlled by our Chairman and Chief Executive Officer, Charif Souki. Our Code of Business Conduct and Ethics prohibits potential conflicts of interest. Upon the recommendation of our Audit Committee, which determined that the terms of the charter letter are fair and in our best interest, our Board

**CHENIERE ENERGY, INC. AND SUBSIDIARIES**  
**NOTES TO CONSOLIDATED FINANCIAL STATEMENTS—(Continued)**

of Directors unanimously approved the terms of the charter letter in May 2005 and granted an exception under our Code of Business Conduct and Ethics in order to permit us to charter the Challenger 600 aircraft. For the year ended December 31, 2005, we incurred \$798,000 related to the charter of the Challenger 600 aircraft owned by the LLC.

In conjunction with our private placement of equity in January 2004, placement fees were paid to T. R. Winston & Company, Inc., a company in which the son of Charif Souki, Cheniere's Chairman and Chief Executive Officer, is employed. Placement fees to T. R. Winston for such placement totaled \$965,000.

In December 2003, we entered into a shareholders agreement whereby we acquired a minority interest in J & S Cheniere. One of the directors of J & S Cheniere is the brother of Charif Souki. We also entered into an option agreement with J & S Cheniere providing for a \$1,000,000 payment to us from J & S Cheniere for the option to acquire regasification capacity at our Sabine Pass and Corpus Christi LNG receiving terminals.

We have made office space available for use by Keith F. Carney, a non-management director. The pro rata amount of office lease expense related to that space was \$3,000, \$3,000 and \$4,000 in 2005, 2004 and 2003, respectively.

**NOTE 21—COMMITMENTS AND CONTINGENCIES**

**Lease Commitments**

*Future Annual Minimum Lease Payments*

Future annual minimum lease payments are as follows (in thousands):

<u>Year Ending December 31,</u>	<u>Operating Leases</u>
2006	\$ 2,024
2007	2,380
2008	2,523
2009	2,449
2010	2,412
Thereafter	38,698
<b>Total</b>	<b>\$ 50,486</b>

*Office Leases*

In October 2003, we entered into a lease agreement for new office space with a term which runs from December 2003 through April 2014. Beginning in April 2004, our monthly lease rental is \$21,000 and escalates to \$24,000 beginning in February 2009 through the remaining term of the lease. We have an option to renew the lease for an additional five years at the then-current market rate. In May 2004, we amended our office lease agreement to increase our rentable square footage, or the Expansion Space. The lease term for the Expansion Space runs from September 2004 through August 2009. Our monthly lease rental for the Expansion Space is \$14,000 beginning in June 2005. We have the option, subject and subordinate to another tenants' renewal option, to renew the lease for an additional five years at a rate specified in this amendment. In March 2005, we amended our office lease to increase our rentable square footage to include an additional floor on the premises. The lease term for the additional floor runs from May 2005 through January 2014. We have an option to renew the lease for an additional five years at the then-current market rate as part of the renewal of our original lease space. Under

**CHENIERE ENERGY, INC. AND SUBSIDIARIES**  
**NOTES TO CONSOLIDATED FINANCIAL STATEMENTS—(Continued)**

the amended lease, there are no monthly lease payments for the additional floor from May 2005 through April 2007, after which time the lease payments range from approximately \$30,000 to \$39,000 per month through January 2014. We have prepaid \$201,000 in rent related to 2013 and have included such amount in Other Assets on the consolidated balance sheet as of December 31, 2005. We are also responsible for our proportionate share of the building operating expenses. In connection with the lease, we have issued a letter of credit in favor of the landlord in the amount of \$674,000. The letter of credit amount decreases by approximately \$225,000 each October for the next three years. In addition, the lease creates a lien on all property that we place on the premises as a security interest for payment of amounts due under the terms of the lease.

*LNG Site Leases*

Our obligations under LNG site options are renewable on an annual or semiannual basis. We may terminate our obligations at any time by electing not to renew or by exercising the options.

In January 2005, we exercised our options and entered into three land leases for our Sabine Pass LNG receiving terminal site. The leases have an initial term of 30 years, with options to renew for six 10-year extensions. In February 2005, two of the three leases were amended, thereby increasing the total acreage under lease to 853 acres and increasing the annual lease payments to \$1,501,000. For 2005, these payments have been capitalized as part of the construction cost of the Sabine Pass LNG receiving terminal; however, beginning in 2006, these lease payments will be expensed as required by FSP 13-1.

Our total rental expense for the years ended December 31, 2005, 2004 and 2003 was \$727,000, \$445,000 and \$128,000, respectively.

**LNG Commitments**

*Obligations under LNG TUAs*

Sabine Pass LNG has entered into TUAs with Total and Chevron USA to provide berthing for LNG tankers and for the unloading, storage and regasification of LNG at our Sabine Pass LNG receiving terminal.

*LNG Option Agreements*

We entered into an agreement with J & S Cheniere under which J & S Cheniere has an option to enter into a TUA reserving up to 200 MMcf/d of capacity at each of our Sabine Pass and Corpus Christi LNG facilities. Following execution of the option agreement, \$1,000,000 was paid by J & S Cheniere to us in January 2004. The terms of the TUA contemplated by the J & S Cheniere option agreement have not been negotiated or finalized. We anticipate that definitive arrangements with J & S Cheniere may involve different terms and transaction structures than were contemplated when the option agreement was entered into in December 2003. Although non-refundable, we have recorded the option fee as deferred revenue.

In January 2004, Corpus Christi LNG, L.P. entered into an option agreement with BPU to provide 100 MMcf/d of regasification capacity at our Corpus Christi LNG receiving terminal. The option agreement was subsequently assigned by BPU to its sole stockholder, BPU Associates, LLC.

*Freeport LNG*

Under the limited partnership agreement of Freeport LNG, development expenses of the Freeport LNG project and other Freeport LNG cash needs generally are to be funded out of Freeport LNG's own cash flows, borrowings or other sources, and, up to a pre-agreed total amount, with capital contributions by the limited

**CHENIERE ENERGY, INC. AND SUBSIDIARIES**  
**NOTES TO CONSOLIDATED FINANCIAL STATEMENTS—(Continued)**

partners. We received capital calls, and made capital contributions, in the amount of approximately \$2,102,000 in 2005. In December 2005, Freeport LNG announced that it had closed a \$383,000,000 private placement of notes, which would be used to fund the remaining portion of the initial phase of the project, a portion of the cost of expanding the LNG receiving terminal and development of underground salt cavern gas storage. As a result of such financing being obtained, we do not anticipate that any capital calls will be made upon the limited partners of Freeport LNG in the foreseeable future. Additional capital calls may be made upon us and the other limited partners in Freeport LNG and in the event of each such future capital call, we will have the option either to contribute the requested capital or to decline to contribute. If we decline to contribute, the other limited partners could elect to make our contribution and receive back twice the amount contributed on our behalf, without interest, before any Freeport LNG cash flows are otherwise distributed to us. We currently expect to evaluate Freeport LNG capital calls on a case-by-case basis and to fund additional capital contributions that we elect to make using cash on hand or funds raised through the issuance of Cheniere equity or debt securities or other Cheniere borrowings.

In connection with the acquisition of the option to lease the Freeport LNG receiving terminal site in June 2001, we issued 1,000,000 shares of common stock valued at \$1,150,000, or \$1.15 per share, the closing price of our common stock on the date of the transaction, to the seller of the lease option. We also committed to issue an additional 1,500,000 shares of our common stock to the seller of the lease option in April 2003, for which we received no additional consideration. These shares were issued in April 2003 at a value of \$1,312,500, or \$0.875 per share, the closing price of our common stock on the date of issuance. The seller of the lease option also obtained the right to receive a royalty payment on the gross quantities of gas processed at LNG terminals that we own. The royalty is generally calculated based on \$0.03 per Mcf of gas processed, subject to a minimum royalty of \$2,000,000 per year and a maximum royalty of \$10,950,000 per year after production begins. In 2002, a long-term lease was secured by Freeport LNG, and at the closing of the sale of our interests in the site and project, Freeport LNG assumed the obligation to pay the royalty with respect to gas processed and produced at the Freeport LNG facility.

**EPC Agreement**

In December 2004, we entered into a lump-sum turnkey EPC agreement with Bechtel pursuant to which Bechtel is providing services for the engineering, procurement and construction of Phase 1 of our Sabine Pass LNG receiving terminal. In December 2004, a limited notice to proceed, or LNTP, was issued and accepted by Bechtel, at which time Bechtel was required to promptly commence performance of certain off-site engineering and preparatory work under the EPC agreement. In early April 2005, a final NTP was issued, and Bechtel commenced all other aspects of work under the EPC agreement.

Sabine Pass LNG agreed to pay Bechtel a contract price of \$646,936,000 plus certain reimbursable costs. This contract price is subject to adjustment for changes in certain commodity prices, contingencies, change orders and other items. Payments under the EPC agreement will be made in accordance with the payment schedule set forth in the EPC agreement. The contract price and payment schedule, including milestones, may be amended only by change order. Bechtel will be liable to Sabine Pass LNG for certain delays in achieving substantial completion, minimum acceptance criteria and performance guarantees. Bechtel will be entitled to a scheduled bonus of \$12,000,000, or a lesser amount in certain cases, if on or before April 3, 2008, Bechtel completes construction sufficient to achieve, among other requirements specified in the EPC agreement, a sendout rate of at least 2.0 Bcf/d for a minimum sustained test period of 24 hours. Bechtel will be entitled to receive an additional bonus of up to \$67,000 per day (up to a maximum of \$6,000,000) for each day that commercial operation is achieved prior to April 1, 2008. As of February 28, 2006, change orders for \$64,845,000 had been approved, increasing the total contract price to \$711,781,000. We anticipate additional change orders

**CHENIERE ENERGY, INC. AND SUBSIDIARIES**  
**NOTES TO CONSOLIDATED FINANCIAL STATEMENTS—(Continued)**

intended to mitigate ongoing effects of the 2005 hurricanes that would increase the contract price by an amount not expected to exceed \$50,000,000. We expect to submit any such change orders to our lenders by May 3, 2006 for approval under the Sabine Pass Credit Facility.

In July 2005, we executed a letter of intent with a potential EPC contractor to negotiate an EPC contract for construction of our Corpus Christi LNG terminal. Subject to certain terms and conditions, in the event that we did not execute an EPC contract with this contractor on or before January 31, 2006, we were obligated to pay the contractor a fee of \$1,000,000. On October 10, 2005, we entered into a Memorandum of Understanding, or MOU, with the same potential EPC contractor to negotiate the terms of an EPC contract for each of the Corpus Christi and Creole Trail LNG receiving terminals. Under the terms of the MOU, the \$1,000,000 fee was cancelled and replaced by a \$500,000 termination fee, payable, with certain exceptions, if we elect to terminate the MOU or if we fail to agree on the terms of an EPC contract for at least one of the terminals by April 30, 2007.

**Other Commitments**

In the ordinary course of business, we have issued surety bonds related to our offshore oil and gas operations and entered into certain multi-year licensing and service agreements, none of which are considered material to our financial position.

**Legal proceedings**

We are, and may in the future be, involved as a party to various legal proceedings, which are incidental to the ordinary course of business. We regularly analyze current information and, as necessary, provide accruals for probable liabilities on the eventual disposition of these matters. In the opinion of management and legal counsel, as of December 31, 2005, there were no threatened or pending legal matters that would have a material impact on our consolidated results of operations, financial position or cash flows.

As previously disclosed, we received a letter dated December 17, 2004 advising us of a nonpublic, informal inquiry being conducted by the SEC. On August 9, 2005, the SEC informed us that it had issued a formal order and commenced a nonpublic factual investigation of actions and communications by Cheniere, its current or former directors, officers and employees and other persons in connection with our agreements and negotiations with Chevron USA, the Company's December 2004 public offering of common stock, and trading in our securities. The scope, focus and subject matter of the SEC investigation may change from time to time, and we may be unaware of matters under consideration by the SEC. We have cooperated fully with the SEC informal inquiry and intend to continue cooperating fully with the SEC in its investigation.

**NOTE 22—GAIN ON SALE OF INVESTMENT IN UNCONSOLIDATED AFFILIATE**

In October 2000, Cheniere and Warburg, Pincus Energy Partners, L.P. formed Gryphon Exploration Company, or Gryphon, to fund an oil and gas exploration program in the Gulf of Mexico. Since January 1, 2003, our investment (effective 9.3% ownership) in Gryphon has been accounted for under the cost method of accounting, and our investment basis was zero. On August 31, 2005, Gryphon was sold for \$283,000,000, plus assumption of \$14,000,000 of net debt in a merger with Woodside Energy (USA). The transaction generated net cash proceeds of \$20,206,000 to us, and since our investment balance was zero at the closing of this transaction, we recognized a gain in our consolidated statement of operations for the year ended December 31, 2005 equal to the net cash proceeds amount.

**NOTE 23—BUSINESS SEGMENT INFORMATION**

Our business activities are conducted within two principal operating segments: LNG receiving terminal development, and oil and gas exploration and development. These segments operate independently.

**CHENIERE ENERGY, INC. AND SUBSIDIARIES**  
**NOTES TO CONSOLIDATED FINANCIAL STATEMENTS—(Continued)**

Our LNG receiving terminal development segment is in various stages of developing three, 100% owned LNG receiving terminal projects along the U.S. Gulf Coast at the following locations: Sabine Pass LNG in western Cameron Parish, Louisiana on the Sabine Pass Channel; Corpus Christi LNG near Corpus Christi, Texas; and Creole Trail LNG at the mouth of the Calcasieu Channel in central Cameron Parish, Louisiana. In addition, we own a 30% minority interest in a fourth project, Freeport LNG, located on Quintana Island near Freeport, Texas. Our related natural gas pipeline development activities and other initiatives that complement the development of our LNG receiving terminal business are also presently included in the segment.

Our oil and gas exploration and development segment explores for oil and natural gas using a regional database of approximately 7,000 square miles of regional 3D seismic data. Exploration efforts are focused on the shallow waters of the Gulf of Mexico offshore of Louisiana and Texas and consist primarily of active interpretation of our seismic data and generation of prospects, through participation in the drilling of wells, and through farm-out arrangements and back-in interests (a reversionary interest in oil and gas leases reserved by us) whereby the capital costs of such activities are borne primarily by industry partners. This segment participates in drilling and production operations with industry partners on the prospects that we generate.

	Segments		Total	Corporate and Other (1)	Total Consolidated
	LNG Receiving Terminal	Oil & Gas Exploration and Development			
	(in thousands)				
As of or for the Year Ended December 31, 2005:					
Revenues	\$ —	\$ 3,005	\$ 3,005	\$ —	\$ 3,005
Depreciation, depletion and amortization	55	2,435	2,490	1,212	3,702
Non-cash compensation expense	1,235	182	1,417	2,021	3,438
Loss from operations	(29,122)	(1,204)	(30,326)	(21,773)	(52,099)
Equity in net loss of equity method investee (2)	(1,031)	—	(1,031)	—	(1,031)
Gain on sale of investment in unconsolidated affiliate (3)	—	20,206	20,206	—	20,206
Derivative gain	837	—	837	—	837
Interest expense	13,826	—	13,826	3,547	17,373
Interest income	2,645	—	2,645	14,875	17,520
Income tax benefit	2,045	—	2,045	—	2,045
Goodwill	76,844	—	76,844	—	76,844
Total assets	783,837	20,305	804,142	503,982	1,308,124
Expenditures for additions to long-lived assets	271,879	4,211	276,090	6,095	282,185
As of or for the Year Ended December 31, 2004:					
Revenues	\$ —	\$ 1,998	\$ 1,998	\$ —	\$ 1,998
Depreciation, depletion and amortization	78	868	946	378	1,324
Income (loss) from operations	(17,245)	17	(17,228)	(11,857)	(29,085)
Equity in net loss of equity method investee (4)	(1,346)	—	(1,346)	—	(1,346)
Reimbursement from limited partnership investment (5)	2,500	—	2,500	—	2,500
Total assets	24,355	19,931	44,286	289,281	333,567
Expenditures for additions to long-lived assets	460	2,676	3,136	868	4,004
As of or for the Year Ended December 31, 2003:					
Revenues	\$ —	\$ 658	\$ 658	\$ —	\$ 658
Depreciation, depletion and amortization	142	192	334	95	429
Income (loss) from operations	(6,847)	466	(6,381)	(2,637)	(9,018)
Equity in net loss of equity method investee (6)	(4,471)	—	(4,471)	—	(4,471)
Gain on sale of LNG assets (7)	4,760	—	4,760	—	4,760
Gain on sale of limited partnership interest (8)	423	—	423	—	423
Total assets	2,953	20,219	23,172	1,419	24,591
Expenditures for additions to long-lived assets	—	2,554	2,554	533	3,087

**CHENIERE ENERGY, INC. AND SUBSIDIARIES**  
**NOTES TO CONSOLIDATED FINANCIAL STATEMENTS—(Continued)**

- (1) Includes corporate activities and certain intercompany eliminations.
- (2) Represents equity in net loss of our investment in Freeport LNG, excluding the 2005 Suspended Loss of \$3,968,000. Our investment basis is zero at December 31, 2005.
- (3) Represents gain on sale of our interest in Gryphon Exploration Company. See Note 22—“Gain on Sale of Investment in Unconsolidated Affiliate”.
- (4) Represents equity in net loss of our investment in Freeport LNG for 2004 totaling \$1,068,000 plus the 2003 Suspended Loss of \$278,000.
- (5) In January 2004, we received the final \$2,500,000 payment due from Freeport LNG. See Note 8—“Investment in Limited Partnership”.
- (6) Represents equity in net loss of our investment in Freeport LNG, excluding the 2003 Suspended Loss of \$278,000. Our investment basis was reduced to zero as of December 31, 2003.
- (7) In February 2003, we sold a 60% interest in our Freeport LNG terminal project to Freeport LNG. A gain of \$4,760,000 was recognized on the sale. See Note 8—“Investment in Limited Partnership”.
- (8) In March 2003, we sold a 10% limited partner interest in Freeport LNG to a third party and recognized a gain of \$423,000. See Note 8—“Investment in Limited Partnership”.

**NOTE 24—SUPPLEMENTAL CASH FLOW INFORMATION AND DISCLOSURES OF NON-CASH TRANSACTIONS**

The following table provides supplemental disclosure of cash flow information (in thousands):

	Year Ended December 31,		
	2005	2004	2003
Cash paid during the year for:			
Interest, net of \$2,669 capitalized	\$ 12,792	\$ 4	\$ 41
Income taxes	\$ —	\$ —	\$ —

In 2005, non-vested stock grants of 175,151 shares were made to employees and outside directors under the 2003 Stock Incentive Plan. We recorded \$6,663,000 to common stock and additional paid-in-capital, offset by a corresponding amount of deferred compensation to stockholders’ equity. During 2005, we recorded \$3,583,000 (before capitalization of \$145,000 as oil and gas property costs) in total non-cash compensation expense. As of December 31, 2005, the balance of non-cash deferred compensation was \$9,684,000.

In 2005, 129,842 shares of our common stock were issued in satisfaction of cashless exercises of stock options and warrants to purchase 33,868 and 100,000 shares, respectively.

In February 2005, we acquired the 33.3% minority interest in Corpus Christi LNG through the acquisition of BPU in exchange for 2,000,000 restricted shares of our common stock valued at \$77,090,000.

In 2004, we recorded \$97,000, the present value of the expected abandonment cost of a well in which we hold a working interest, and its related equipment, as a long-term asset retirement obligation. A corresponding amount was recorded to proved oil and gas properties. Non-cash accretion expense for 2005 and 2004 was \$3,000 and \$2,000, respectively, and was included in depreciation, depletion and amortization expense.

In December 2003, the minority interest owner of Corpus Christi LNG contributed two tracts of land valued at \$311,000 to be used for the LNG terminal site.

In August 2003, we issued 756,616 shares of common stock in exchange for the surrender of warrants to purchase 1,400,000 shares in a cashless transaction.

**CHENIERE ENERGY, INC. AND SUBSIDIARIES**  
**NOTES TO CONSOLIDATED FINANCIAL STATEMENTS—(Continued)**

In April 2003, pursuant to a contingent contractual obligation related to our 2001 acquisition of an option to lease the Freeport LNG terminal site, we issued 1,500,000 shares of our common stock, valued at \$1,312,000 on the date of issuance, to satisfy a closing requirement related to the February 2003 sale of a 60% interest in our Freeport LNG project

In February 2003, in connection with the sale of a 60% interest in the Freeport LNG site and project, we issued warrants valued at \$540,000 to purchase 1,400,000 shares of common stock. As a result of the closing of the Freeport transaction, we issued warrants valued at \$174,000 to purchase 450,000 shares of common stock to LNG consultants for services previously performed for us. In connection with the sale of a 10% interest in Freeport LNG, we issued warrants valued at \$242,000 to purchase 600,000 shares of common stock to the purchaser, and the purchaser canceled the \$750,000 note previously payable by us. These transactions are described in more detail in Note 8—"Investment in Limited Partnership".

**NOTE 25—SUBSEQUENT EVENTS**

At December 31, 2005, there were no borrowings outstanding under the Sabine Pass Credit Facility; however, as of February 28, 2006, \$58,500,000 had been drawn under the Sabine Pass Credit Facility.

On January 3, 2006, 78,671 shares, valued at \$37.71 per share, were granted to executive officers in the form of non-vested (restricted) stock awards relating to our performance in 2005.

During January and February 2006, we issued 141,003 shares of common stock pursuant to the exercise of stock options at an average price of \$7.37 generating proceeds of \$1,039,000.

On February 21, 2006, Cheniere Sabine Pass Pipeline Company, our wholly-owned subsidiary, entered into an EPC pipeline contract with Willbros Engineering, Inc., or Willbros. Under the EPC pipeline contract, Willbros will provide Cheniere Sabine Pass Pipeline Company with services for the management, engineering, material procurement, construction and construction management of the Sabine Pass pipeline. Sabine Pass Pipeline Company will pay to Willbros a contract price not to exceed \$67,700,000 subject to additions and deductions by any change order as provided in the EPC pipeline contract, excluding certain Louisiana sales and use taxes, which Cheniere Sabine Pass Pipeline Company is obligated to reimburse. Cheniere Sabine Pass Pipeline Company entered into the EPC pipeline contract sufficiently in advance of commencement of physical construction of the pipeline in order to perform detailed engineering and procure materials.



**CHENIERE ENERGY, INC. AND SUBSIDIARIES**  
**SUPPLEMENTAL INFORMATION TO CONSOLIDATED FINANCIAL STATEMENTS**  
**OIL AND GAS RESERVES AND RELATED FINANCIAL DATA**  
(unaudited)

**Costs Incurred in Oil and Gas Producing Activities**

Presented below are costs incurred in oil and gas property acquisition, exploration and development activities (in thousands):

	Year Ended December 31,		
	2005	2004	2003
Acquisition of properties			
Proved properties	\$ —	\$ —	\$ —
Unproved properties	1,530	318	937
Exploration costs	2,681	2,261	1,577
Development costs	—	—	—
Subtotal	<u>\$4,211</u>	<u>\$2,579</u>	<u>\$2,514</u>
Asset retirement costs	—	97	—
Total	<u>\$4,211</u>	<u>\$2,676</u>	<u>\$2,514</u>

Included in the costs incurred for the years ended December 31, 2005, 2004 and 2003 was \$927,000, \$1,573,000 and \$1,064,000, respectively, of capitalized general and administrative expenses, capitalized interest expense and capitalized debt discount directly related to property acquisition, exploration and development.

**Capitalized Costs Related to Oil and Gas Producing Activities**

The following table presents total capitalized costs of proved and unproved properties and accumulated depreciation, depletion and amortization related to oil and gas producing operations (in thousands):

	December 31,	
	2005	2004
Proved properties	\$ 5,787	\$ 3,339
Unproved properties	17,216	16,688
	<u>23,003</u>	<u>20,027</u>
Accumulated depreciation, depletion and amortization	(3,386)	(971)
	<u>\$19,617</u>	<u>\$19,056</u>

**Costs Not Being Amortized**

Presented below is a summary of oil and gas property costs not being amortized at December 31, 2005, by the year in which such costs were incurred. Such costs include capitalized interest of \$169,000. The majority of the evaluation activities are expected to be completed within three years.

	Cumulative Balance at December 31, 2005	Costs incurred for the year ended December 31,			
		2005	2004	2003	2002 and earlier
		(in thousands)			
Acquisition costs	\$ 1,322	\$ 991	\$ 291	\$ 18	\$ 22
Exploration costs	15,894	1,473	336	1,035	13,050
Development costs	—	—	—	—	—
Total	<u>\$ 17,216</u>	<u>\$ 2,464</u>	<u>\$ 627</u>	<u>\$ 1,053</u>	<u>\$ 13,072</u>

[Table of Contents](#)

**CHENIERE ENERGY, INC. AND SUBSIDIARIES**  
**SUPPLEMENTAL INFORMATION TO CONSOLIDATED FINANCIAL STATEMENTS**  
**OIL AND GAS RESERVES AND RELATED FINANCIAL DATA—(Continued)**  
(unaudited)

**Results of Operations from Oil and Gas Producing Activities**

The results of operations from oil and gas producing activities are as follows (in thousands):

	Year Ended December 31,		
	2005	2004	2003
Revenues	\$ 3,005	\$ 1,998	\$ 658
Production costs	(237)	(117)	—
Depreciation, depletion and amortization (1)	(2,418)	(837)	(122)
<b>Results of operations from oil and gas producing activities (excluding corporate overhead and interest costs)</b>	<b>\$ 350</b>	<b>\$ 1,044</b>	<b>\$ 536</b>

(1) Includes \$3,000 and \$2,000 of asset retirement accretion expense in 2005 and 2004, respectively.

**Reserve Quantities**

Estimates of our proved reserves and the related standardized measure of discounted future net cash flow information are based on the reports generated by our independent petroleum engineers, Sharp Petroleum Engineering, Inc., in accordance with the rules and regulations of the SEC. The independent engineers' estimates were based upon a review of production histories and other geologic, economic, ownership and engineering data provided by us. These estimates represent our interest in the reserves associated with our properties. All of our oil and gas reserves are located within the United States or its territorial waters.

Our estimates of proved reserves and proved developed reserves of oil and gas as of December 31, 2005, 2004 and 2003 and the changes in our proved reserves are as follows:

	2005		2004		2003	
	Oil (Bbls)	Gas (Mcf)	Oil (Bbls)	Gas (Mcf)	Oil (Bbls)	Gas (Mcf)
<b>Proved reserves:</b>						
Beginning of year	3,021	919,120	5,123	912,779	3,980	1,333,000
Revisions of prior estimates	459	(132,149)	(738)	(159,303)	(3,830)	(1,093,920)
Production	(2,167)	(396,284)	(1,364)	(328,676)	(17)	(123,392)
Sale of reserves in place	—	—	—	—	—	—
Extensions, discoveries and other additions	—	—	—	494,320	4,990	797,091
<b>End of year</b>	<b>1,313</b>	<b>390,687</b>	<b>3,021</b>	<b>919,120</b>	<b>5,123</b>	<b>912,779</b>
<b>Proved developed reserves:</b>						
Beginning of year	3,021	919,120	3,024	759,095	1,606	503,000
<b>End of year</b>	<b>1,313</b>	<b>390,687</b>	<b>3,021</b>	<b>919,120</b>	<b>3,024</b>	<b>759,095</b>

There are numerous uncertainties inherent in estimating quantities of proved reserves and in projecting future rates of production and future amounts and timing of development expenditures, including many factors beyond our control. Reserve engineering is a subjective process of estimating underground accumulations of crude oil and natural gas that cannot be measured in an exact manner, and the accuracy of any reserve estimate is a function of the quality of available data and of engineering and geological interpretation and judgment.

**CHENIERE ENERGY, INC. AND SUBSIDIARIES**  
**SUPPLEMENTAL INFORMATION TO CONSOLIDATED FINANCIAL STATEMENTS**  
**OIL AND GAS RESERVES AND RELATED FINANCIAL DATA—(Continued)**  
(unaudited)

Estimates of proved undeveloped reserves are inherently less certain than estimates of proved developed reserves. The quantities of oil and gas that are ultimately recovered, production and operating costs, the amount and timing of future development expenditures, geologic success and future oil and gas sales prices may all differ from those assumed in these estimates. In addition, our reserves may be subject to downward or upward revision based upon production history, purchases or sales of properties, results of future development, prevailing oil and gas prices and other factors.

**Standardized Measure of Discounted Future Net Cash Flows**

The standardized measure of discounted future net cash flows was calculated by applying year-end prices (adjusted for location and quality differentials) to estimated future production, less future expenditures (based on year-end costs) to be incurred in developing and producing our proved reserves and the estimated effect of future income taxes based on the current tax law. The resulting future net cash flows were discounted using a rate of 10% per annum.

From our inception, we have recorded annual net operating losses for both financial reporting purposes and for federal and state income tax reporting purposes. Accordingly, we are not presently a taxpayer, and therefore there is no tax effect on future net cash flow amounts.

The standardized measure of discounted future net cash flow amounts contained in the following tabulation does not purport to represent the fair market value of oil and gas properties. No value has been given to unproved properties. There are significant uncertainties inherent in estimating quantities of proved reserves and in projecting rates of production and the timing and amount of future costs. Future realization of oil and gas prices over the remaining reserve lives may vary significantly from current prices. In addition, the method of valuation utilized, based on year-end prices and costs and the use of a 10% discount rate, is not necessarily appropriate for determining fair value.

The standardized measure of discounted future net cash flows relating to proved oil and gas reserves is as follows (in thousands):

	December 31,		
	2005	2004	2003
Future gross revenues	\$3,548	\$5,666	\$5,231
Less—future costs:			
Production	(212)	(570)	(134)
Development and abandonment	(80)	(80)	—
Income taxes	—	—	—
Future net cash flows	3,256	5,016	5,097
Less—10% annual discount for estimated timing of cash flows	(511)	(868)	(819)
Standardized measure of discounted future net cash flows	\$2,745	\$4,148	\$4,278

**CHENIERE ENERGY, INC. AND SUBSIDIARIES**  
**SUPPLEMENTAL INFORMATION TO CONSOLIDATED FINANCIAL STATEMENTS**  
**OIL AND GAS RESERVES AND RELATED FINANCIAL DATA—(Continued)**  
(unaudited)

The following table summarizes the principal sources of change in the standardized measure of discounted future net cash flows (in thousands, except for prices):

	Year Ended December 31,		
	2005	2004	2003
Standardized measure—beginning of period	\$ 4,148	\$ 4,278	\$ 5,131
Sales of oil and gas produced, net of production costs	(2,768)	(1,881)	(657)
Extensions, discoveries and other additions	—	1,849	3,692
Revisions to previous quantity estimates, timing and other	58	(698)	(4,945)
Net changes in prices and production costs	971	268	727
Sale of reserves in place	—	—	—
Development costs incurred	—	—	—
Changes in estimated development costs	—	—	—
Net changes in income taxes	—	—	—
Accretion of discount	336	332	330
Standardized measure—end of period	<u>\$ 2,745</u>	<u>\$ 4,148</u>	<u>\$ 4,278</u>
Current prices at year-end, used in standardized measure			
Oil (per Bbl)	\$ 53.72	\$ 38.10	\$ 31.00
Gas (per Mcf)	\$ 8.90	\$ 6.04	\$ 5.63

We may receive amounts different from those incorporated into the standardized measure of discounted cash flow for a number of reasons, including changes in prices. Therefore, the present value shown above should not be construed as the current market value of the estimated oil and gas reserves attributable to our properties.

**CHENIERE ENERGY, INC. AND SUBSIDIARIES**  
**SUPPLEMENTAL INFORMATION TO CONSOLIDATED FINANCIAL STATEMENTS**  
**SUMMARIZED QUARTERLY FINANCIAL DATA**  
(unaudited)

**Quarterly Financial Data—(in thousands)**

	<u>First Quarter</u>	<u>Second Quarter</u>	<u>Third Quarter</u>	<u>Fourth Quarter</u>	<u>Year</u>
<b>Year ended December 31, 2005:</b>					
Revenues	\$ 737	\$ 689	\$ 729	\$ 850	\$ 3,005
Gross profit (1)	334	368	320	(672)	350
Loss from operations	(10,261)	(10,823)	(10,681)	(20,334)	(52,099)
Net income (loss) (2)	(9,215)	(9,837)	7,678	(18,424)	(29,798)
Net income (loss) per share—basic and diluted	\$ (0.18)	\$ (0.18)	\$ 0.14	\$ (0.34)	\$ (0.56)
<b>Year ended December 31, 2004:</b>					
Revenues	\$ 332	\$ 335	\$ 465	\$ 866	\$ 1,998
Gross profit (1)	247	243	346	177	1,013
Loss from operations	(7,218)	(7,327)	(5,505)	(9,035)	(29,085)
Net loss (3)	(1,075)	(8,053)	(5,639)	(9,801)	(24,568)
Net loss per share—basic and diluted	\$ (0.03)	\$ (0.22)	\$ (0.15)	\$ (0.23)	\$ (0.63)

(1) Revenues less production costs and oil and gas depreciation, depletion and amortization.

(2) The third quarter of 2005 includes \$20,206,000 gain on sale of our investment in Gryphon Exploration Company. See Note 22—"Gain on Sale of Investment in Unconsolidated Affiliate".

(3) The first quarter of 2004 includes a \$2,500,000 gain recognized on receipt of the final \$2,500,000 payment from Freeport LNG. See Note 8—"Investment in Limited Partnership".

[Table of Contents](#)

**ITEM 9. CHANGES IN AND DISAGREEMENTS WITH ACCOUNTANTS ON ACCOUNTING AND FINANCIAL DISCLOSURE**

None.

**ITEM 9A. CONTROLS AND PROCEDURES**

**Evaluation of Disclosure Controls and Procedures**

Based on their evaluation as of the end of the fiscal year ended December 31, 2005, our principal executive officer and principal financial officer have concluded that our disclosure controls and procedures (as defined in Rules 13a-15(e) and 15d-15(e) under the Exchange Act) are effective to ensure that information required to be disclosed in reports that we file or submit under the Exchange Act are recorded, processed, summarized and reported within the time periods specified in the SEC's rules and forms.

During the most recent fiscal quarter, there have been no changes in our internal control over financial reporting that have materially affected, or are reasonably likely to materially affect, our internal control over financial reporting.

**Management Report on Internal Control Over Financial Reporting**

Our Management Report on Internal Control Over Financial Reporting is included in the Financial Statements on page 73 and is incorporated herein by reference.

**ITEM 9B. OTHER INFORMATION**

None.

**PART III**

Pursuant to paragraph 3 of General Instruction G to Form 10-K, the information required by Items 10 through 14 of Part III of this Report is incorporated by reference from Cheniere's definitive proxy statement involving the election of directors, which is to be filed pursuant to Regulation 14A within 120 days after the end of Cheniere's fiscal year ended December 31, 2005.

**PART IV**

**ITEM 15. EXHIBITS AND FINANCIAL STATEMENT SCHEDULES**

- (a) Financial Statements, Schedules and Exhibits
- (1) Financial Statements—Cheniere Energy, Inc. and Subsidiaries:

<a href="#">Management Reports to the Stockholders of Cheniere Energy, Inc.</a>	73
<a href="#">Reports of Independent Registered Public Accounting Firm</a>	74
<a href="#">Consolidated Balance Sheet</a>	76
<a href="#">Consolidated Statement of Operations</a>	77
<a href="#">Consolidated Statement of Stockholders' Equity</a>	78
<a href="#">Consolidated Statement of Cash Flows</a>	79
<a href="#">Notes to Consolidated Financial Statements</a>	80
<a href="#">Supplemental Information to Consolidated Financial Statements—Oil and Gas Reserves and Related Financial Data</a>	111
<a href="#">Supplemental Information to Consolidated Financial Statements—Summarized Quarterly Financial Data</a>	115

## Table of Contents

The financial statements of Freeport LNG Development, L.P. for the period from December 1, 2002 to December 31, 2005, for which Cheniere used the equity method of accounting, have been filed as part of this report on Form 10-K. (See Item 15(c))

(2) Financial Statement Schedules

All consolidated financial statement schedules have been omitted because they are not required, are not applicable, or the required information has been included elsewhere within this Form 10-K.

(3) Exhibits

<u>Exhibit No.</u>	<u>Description</u>
1.1*	Underwriting Agreement, dated as of December 2, 2004, by and among Cheniere Energy, Inc. (the "Company") and the Underwriters named on Schedule I thereto. (Incorporated by reference to Exhibit 1.1 to the Company's Current Report on Form 8-K (SEC File No. 001-16383), filed on December 6, 2004)
1.2*	Purchase Agreement, dated as of July 22, 2005, between Cheniere Energy, Inc. and Credit Suisse First Boston LLC. (Incorporated by reference to Exhibit 4.1 of the Company's Current Report on Form 8-K (SEC File No. 001-16383), filed on July 27, 2005)
2.1*	Seismic Data Purchase Agreement, dated June 21, 2000 between Seitel Data Ltd. and the Company. (Incorporated by reference to Exhibit 10.39 of the Company's Quarterly Report on Form 10-Q for the quarter ended June 30, 2000 (SEC File No. 000-09092), filed on August 11, 2000)
2.2*	Settlement and Purchase Agreement, dated and effective as of June 14, 2001 by and between the Company, CXY Corporation, Crest Energy, L.L.C., Crest Investment Company and Freeport LNG Terminal, LLC. (Incorporated by reference to Exhibit 10.10 of the Company's Annual Report on Form 10-K for the fiscal year ended December 31, 2001 (SEC File No. 001-16383), filed on April 1, 2002)
2.3*	Agreement and Plan of Merger, dated February 8, 2005, by and among Cheniere LNG, Inc., Cheniere Acquisition, LLC, BPU Associates, LLC and BPU LNG, Inc. (Incorporated by reference to Exhibit 2.1 to the Company's Current Report on Form 8-K (SEC File No. 001-16383), filed on February 8, 2005)
3.1*	Restated Certificate of Incorporation of the Company. (Incorporated by reference to Exhibit 4.1 of the Company's Quarterly Report on Form 10-Q for the fiscal quarter ended June 30, 2004 (SEC File No. 001-16383), filed on August 10, 2004)
3.2*	Certificate of Amendment of Restated Certificate of Incorporation of the Company. (Incorporated by reference to Exhibit 3.1 of the Company's Current Report on Form 8-K (SEC File No. 001-16383), filed on February 8, 2005)
3.3*	Amended and Restated By-laws of the Company. (Incorporated by reference to Exhibit 4.3 of the Company's Registration Statement on Form S-8 (SEC File No. 333-112379), filed on January 20, 2004)
3.4*	Amendment No. 1 to Amended and Restated By-laws of the Company. (Incorporated by reference to Exhibit 3.1 of the Company's Quarterly Report on Form 10-Q for the quarter ended March 31, 2005 (SEC File No. 001-16383), filed on May 6, 2005)
4.1*	Specimen Common Stock Certificate of the Company. (Incorporated by reference to Exhibit 4.1 of the Company's Registration Statement on Form S-1 (SEC File No. 333-10905), filed on August 27, 1996)

## Table of Contents

<u>Exhibit No.</u>	<u>Description</u>
4.2*	Certificate of Designation of Series A Junior Participating Preferred Stock. (Incorporated by reference to Exhibit 3.1 to the Company's Current Report on Form 8-K (SEC File No. 001-16383), filed on October 14, 2004)
4.3*	Rights Agreement by and between the Company and U.S. Stock Transfer Corp., as Rights Agent, dated as of October 14, 2004. (Incorporated by reference to Exhibit 4.1 to the Company's Current Report on Form 8-K (SEC File No. 001-16383), filed on October 14, 2004)
4.4*	First Amendment to Rights Agreement by and between the Company and U.S. Stock Transfer Corp., as Rights Agent, dated January 24, 2005. (Incorporated by reference to Exhibit 4.1 to the Company's Current Report on Form 8-K (SEC File No. 001-16383), filed on January 24, 2005)
4.5*	Piggy-Back Registration Rights Agreement, dated February 8, 2005, by and between the Company and BPU Associates, LLC. (Incorporated by reference to Exhibit 4.1 to the Company's Current Report on Form 8-K (SEC File No. 001-16383), filed on February 8, 2005)
4.6*	Registration Rights Agreement, dated as of July 27, 2005, between Cheniere Energy, Inc. and Credit Suisse First Boston LLC. (Incorporated by reference to Exhibit 4.2 of the Company's Current Report on Form 8-K (SEC File No. 001-16383), filed on July 27, 2005)
4.7*	Indenture, dated as of July 27, 2005, between Cheniere Energy, Inc., as issuer, and The Bank of New York, as trustee. (Incorporated by reference to Exhibit 4.3 of the Company's Current Report on Form 8-K (SEC File No. 001-16383), filed on July 27, 2005)
10.1*†	Cheniere Energy, Inc. Amended and Restated 1997 Stock Option Plan. (Incorporated by reference to Exhibit 10.14 of the Company's Quarterly on Form 10-Q for the quarter ended September 30, 2005 (SEC File No. 000-16383), filed on November 4, 2005)
10.2*†	Cheniere Energy, Inc. Amended and Restated 2003 Stock Incentive Plan. (Incorporated by reference to Exhibit 10.14 of the Company's Quarterly Report on Form 10-Q for the quarter ended September 30, 2005 (SEC File No. 001-16383), filed on November 4, 2005)
10.3 †	Addendum to Cheniere Energy, Inc. Amended and Restated 2003 Stock Incentive Plan
10.4*†	Form of Non-Qualified Stock Option Grant (four-year vesting) under the Cheniere Energy, Inc. 2003 Stock Incentive Plan. (Incorporated by reference to Exhibit 10.10 to the Company's Annual Report on Form 10-K (SEC File No. 001-16383), filed on March 10, 2005)
10.5*†	Form of Non-Qualified Stock Option Grant (three-year vesting) under the Cheniere Energy, Inc. 2003 Stock Incentive Plan. (Incorporated by reference to Exhibit 10.11 to the Company's Annual Report on Form 10-K (SEC File No. 001-16383), filed on March 10, 2005)
10.6*†	Form of Restricted Stock Grant under the Cheniere Energy, Inc. 2003 Stock Incentive Plan. (Incorporated by reference to Exhibit 10.12 to the Company's Annual Report on Form 10-K (SEC File No. 001-16383), filed on March 10, 2005)
10.7*†	Form of Cancellation and Grant of Non-Qualified Stock Options (three-year vesting) under the Cheniere Energy, Inc. 2003 Stock Incentive Plan. (Incorporated by reference to Exhibit 10.1 of the Company's Current Report on Form 8-K (SEC File No. 001-16383), filed on August 2, 2005)
10.8*	LNG Terminal Use Agreement, dated September 2, 2004, by and between Total LNG USA, Inc. and Sabine Pass LNG, L.P. (Incorporated by reference to Exhibit 10.1 to the Company's Quarterly Report on Form 10-Q (SEC File No. 001-16383), filed on November 15, 2004)
10.9*	Amendment of LNG Terminal Use Agreement, dated January 24, 2005, by and between Total LNG USA, Inc. and Sabine Pass LNG, L.P. (Incorporated by reference to Exhibit 10.40 to the Company's Annual Report on Form 10-K (SEC File No. 001-16383), filed on March 10, 2005)



## Table of Contents

<u>Exhibit No.</u>	<u>Description</u>
10.10*	Omnibus Agreement, dated September 2, 2004, by and between Total LNG USA, Inc. and Sabine Pass LNG, L.P. (Incorporated by reference to Exhibit 10.2 to the Company's Quarterly Report on Form 10-Q (SEC File No. 001-16383), filed on November 15, 2004)
10.11*	Guaranty, dated as of November 9, 2004, by Total S.A. in favor of Sabine Pass LNG, L.P. (Incorporated by reference to Exhibit 10.3 to the Company's Quarterly Report on Form 10-Q (SEC File No. 001-16383), filed on November 15, 2004)
10.12*	LNG Terminal Use Agreement, dated November 8, 2004, between Chevron U.S.A. Inc. and Sabine Pass LNG, L.P. (Incorporated by reference to Exhibit 10.4 to the Company's Quarterly Report on Form 10-Q (SEC File No. 001-16383), filed on November 15, 2004)
10.13*	Omnibus Agreement, dated November 8, 2004, between Chevron U.S.A., Inc. and Sabine Pass LNG, L.P. (Incorporated by reference to Exhibit 10.5 to the Company's Quarterly Report on Form 10-Q (SEC File No. 001-16383), filed on November 15, 2004)
10.14*	Lump Sum Turnkey Engineering, Procurement and Construction Agreement dated December 18, 2004 between Sabine Pass LNG, L.P. and Bechtel Corporation. (Incorporated by reference to Exhibit 10.1 to the Company's Current Report on Form 8-K (SEC File No. 001-16383), filed on December 20, 2004)
10.15	Change Orders 1 through 27 to Lump Sum Turnkey Engineering, Procurement and Construction Agreement dated December 18, 2004 between Sabine Pass LNG, L.P. and Bechtel Corporation
10.16*	Credit Agreement, dated February 25, 2005, among Sabine Pass LNG, L.P., Société Générale, HSBC Bank USA, National Association and the Lenders named thereto. (Incorporated by reference to Exhibit 10.1 to the Company's Current Report on Form 8-K (SEC File No. 001-16383), filed on March 2, 2005)
10.17*	Consent and Waiver No. 1 to Credit Agreement, dated as of April 4, 2005, among Sabine Pass LNG, L.P., Société Générale and HSBC Bank USA, National Association (Incorporated by reference to Exhibit 10.1 of the Company's Quarterly Report on Form 10-Q for the quarter ended March 31, 2005 (SEC File No. 001-16383), filed on May 6, 2005)
10.18*	Consent and Waiver No. 2 to Credit Agreement, dated as of May 5, 2005, among Sabine Pass LNG, L.P., Société Générale and HSBC Bank USA, National Association. (Incorporated by reference to Exhibit 10.1 of the Company's Quarterly Report on Form 10-Q for the quarter ended June 30, 2005 (SEC File No. 001-16383), filed on August 5, 2005)
10.19*	Consent and Waiver No. 3 to Credit Agreement, dated as of April 25, 2005, among Sabine Pass LNG, L.P., Société Générale and HSBC Bank USA, National Association. (Incorporated by reference to Exhibit 10.2 of the Company's Quarterly Report on Form 10-Q for the quarter ended June 30, 2005 (SEC File No. 001-16383), filed on August 5, 2005)
10.20*	Consent and Waiver No. 4 to Credit Agreement, dated as of May 31, 2005, among Sabine Pass LNG, L.P., Société Générale and HSBC Bank USA, National Association. (Incorporated by reference to Exhibit 10.3 of the Company's Quarterly Report on Form 10-Q for the quarter ended June 30, 2005 (SEC File No. 001-16383), filed on August 5, 2005)
10.21*	Consent and Waiver No. 5 to Credit Agreement, dated as of July 5, 2005, among Sabine Pass LNG, L.P., Société Générale and HSBC Bank USA, National Association. (Incorporated by reference to Exhibit 10.10 of the Company's Quarterly Report on Form 10-Q for the quarter ended September 30, 2005 (SEC File No. 001-16383), filed on November 4, 2005)
10.22*	Consent and Waiver No. 6 to Credit Agreement, dated as of July 27, 2005, among Sabine Pass LNG, L.P., Société Générale and HSBC Bank USA, National Association. (Incorporated by reference to Exhibit 10.11 of the Company's Quarterly Report on Form 10-Q for the quarter ended September 30, 2005 (SEC File No. 001-16383), filed on November 4, 2005)

## Table of Contents

<u>Exhibit No.</u>	<u>Description</u>
10.23*	Consent and Waiver No. 7 to Credit Agreement, dated as of August 29, 2005, among Sabine Pass LNG, L.P., Société Générale and HSBC Bank USA, National Association. (Incorporated by reference to Exhibit 10.12 of the Company's Quarterly Report on Form 10-Q for the quarter ended September 30, 2005 (SEC File No. 001-16383), filed on November 4, 2005)
10.24	Consent and Waiver No. 8 to Credit Agreement, dated as of November 28, 2005, among Sabine Pass LNG, L.P., Société Générale and HSBC Bank USA, National Association
10.25	Consent and Waiver No. 9 to Credit Agreement, dated as of January 23, 2006, among Sabine Pass LNG, L.P., Société Générale and HSBC Bank USA, National Association
10.26	Consent and Waiver No. 10 to Credit Agreement, dated as of February 17, 2006, among Sabine Pass LNG, L.P., Société Générale and HSBC Bank USA, National Association
10.27*	Security Agreement, dated February 25, 2005, among Sabine Pass LNG, L.P., Société Générale, and HSBC Bank USA, National Association. (Incorporated by reference to Exhibit 10.2 to the Company's Current Report on Form 8-K (SEC File No. 001-16383), filed on March 2, 2005)
10.28*	Pledge Agreement, dated February 25, 2005, among Sabine Pass LNG-LP, LLC, Sabine Pass LNG-GP, Inc., Société Générale, Sabine Pass LNG, L.P. and HSBC Bank USA, National Association. (Incorporated by reference to Exhibit 10.3 to the Company's Current Report on Form 8-K (SEC File No. 001-16383), filed on March 2, 2005)
10.29*	Collateral Agency Agreement, dated February 25, 2005, among Sabine Pass LNG, L.P., HSBC Bank USA, National Association and Société Générale. (Incorporated by reference to Exhibit 10.4 to the Company's Current Report on Form 8-K (SEC File No. 001-16383), filed on March 2, 2005)
10.30*	Operation and Maintenance Agreement, dated February 25, 2005, between Sabine Pass LNG, L.P. and Cheniere LNG O&M Services, L.P. (Incorporated by reference to Exhibit 10.5 to the Company's Current Report on Form 8-K (SEC File No. 001-16383), filed on March 2, 2005)
10.31*	Management Services Agreement, dated February 25, 2005, between Sabine Pass LNG-GP, Inc. and Sabine Pass LNG, L.P. (Incorporated by reference to Exhibit 10.6 to the Company's Current Report on Form 8-K (SEC File No. 001-16383), filed on March 2, 2005)
10.32*	International Swap Dealers Association, Inc. Master Agreement and Schedules, dated February 25, 2005, between HSBC Bank USA, National Association and Sabine Pass LNG, L.P. (Incorporated by reference to Exhibit 10.7 to the Company's Current Report on Form 8-K (SEC File No. 001-16383), filed on March 2, 2005)
10.33*	Confirmation, dated February 25, 2005, effective July 25, 2005, between HSBC Bank USA, National Association and Sabine Pass LNG, L.P. (Incorporated by reference to Exhibit 10.8 to the Company's Current Report on Form 8-K (SEC File No. 001-16383), filed on March 2, 2005)
10.34*	Confirmation, dated February 25, 2005, effective March 25, 2009, between HSBC Bank USA, National Association and Sabine Pass LNG, L.P. (Incorporated by reference to Exhibit 10.9 to the Company's Current Report on Form 8-K (SEC File No. 001-16383), filed on March 2, 2005)
10.35*	International Swap Dealers Association, Inc. Master Agreement and Schedules, dated February 25, 2005, between Société Générale, New York, and Sabine Pass LNG, L.P. (Incorporated by reference to Exhibit 10.10 to the Company's Current Report on Form 8-K (SEC File No. 001-16383), filed on March 2, 2005)
10.36*	Confirmation, dated February 25, 2005, effective July 25, 2005, between Société Générale, New York, and Sabine Pass LNG, L.P. (Incorporated by reference to Exhibit 10.11 to the Company's Current Report on Form 8-K (SEC File No. 001-16383), filed on March 2, 2005)

## Table of Contents

<u>Exhibit No.</u>	<u>Description</u>
10.37*	Confirmation, dated February 25, 2005, effective March 25, 2009, between Société Générale, New York, and Sabine Pass LNG, L.P. (Incorporated by reference to Exhibit 10.12 to the Company's Current Report on Form 8-K (SEC File No. 001-16383), filed on March 2, 2005)
10.38*	Secured Party Addition Agreement, dated February 25, 2005, executed by HSBC Bank, National Association. (Incorporated by reference to Exhibit 10.13 to the Company's Current Report on Form 8-K (SEC File No. 001-16383), filed on March 2, 2005)
10.39*	Secured Party Addition Agreement, dated February 25, 2005, executed by Société Générale. (Incorporated by reference to Exhibit 10.14 to the Company's Current Report on Form 8-K (SEC File No. 001-16383), filed on March 2, 2005)
10.40*	Confirmation, dated July 22, 2005, between Cheniere Energy, Inc. and Credit Suisse First Boston International. (Incorporated by reference to Exhibit 10.1 of the Company's Current Report on Form 8-K (SEC File No. 001-16383), filed on July 22, 2005)
10.41*	Credit Agreement, dated August 31, 2005, among Cheniere LNG Holdings, LLC, the initial lenders named therein, and Credit Suisse, Cayman Islands Branch. (Incorporated by reference to Exhibit 10.1 of the Company's Quarterly Report on Form 10-Q for the quarter ended September 30, 2005 (SEC File No. 001-16383), filed on November 4, 2005)
10.42*	Security Agreement, dated August 31, 2005, from Cheniere LNG Holdings, LLC to Credit Suisse, Cayman Islands Branch. (Incorporated by reference to Exhibit 10.1 of the Company's Quarterly Report on Form 10-Q for the quarter ended September 30, 2005 (SEC File No. 001-16383), filed on November 4, 2005)
10.43*	Pledge Agreement, dated August 31, 2005, from Cheniere LNG-LP Interests, LLC to Credit Suisse, Cayman Islands Branch. (Incorporated by reference to Exhibit 10.1 of the Company's Quarterly Report on Form 10-Q for the quarter ended September 30, 2005 (SEC File No. 001-16383), filed on November 4, 2005)
10.44*	Control Agreement, dated August 31, 2005, from Cheniere LNG Holdings, LLC, to Credit Suisse, Cayman Islands Branch, and The Bank of New York. (Incorporated by reference to Exhibit 10.1 of the Company's Quarterly Report on Form 10-Q for the quarter ended September 30, 2005 (SEC File No. 001-16383), filed on November 4, 2005)
10.45*	Novation Confirmation (#9233022), dated September 6, 2005, among Credit Suisse First Boston International, Cheniere Energy, Inc. and Cheniere LNG Holdings, LLC. (Incorporated by reference to Exhibit 10.1 of the Company's Quarterly Report on Form 10-Q for the quarter ended September 30, 2005 (SEC File No. 001-16383), filed on November 4, 2005)
10.46*	Novation Confirmation (#9233023), dated August 31, 2005, among Credit Suisse First Boston International, Cheniere Energy, Inc. and Cheniere LNG Holdings, LLC. (Incorporated by reference to Exhibit 10.1 of the Company's Quarterly Report on Form 10-Q for the quarter ended September 30, 2005 (SEC File No. 001-16383), filed on November 4, 2005)
10.47*	Novation Confirmation (#9233025), dated August 31, 2005, among Credit Suisse First Boston International, Cheniere Energy, Inc. and Cheniere LNG Holdings, LLC. (Incorporated by reference to Exhibit 10.1 of the Company's Quarterly Report on Form 10-Q for the quarter ended September 30, 2005 (SEC File No. 001-16383), filed on November 4, 2005)
10.48*	Novation Confirmation (#9233026), dated August 31, 2005, among Credit Suisse First Boston International, Cheniere Energy, Inc. and Cheniere LNG Holdings, LLC. (Incorporated by reference to Exhibit 10.1 of the Company's Quarterly Report on Form 10-Q for the quarter ended September 30, 2005 (SEC File No. 001-16383), filed on November 4, 2005)

---

## Table of Contents

<u>Exhibit No.</u>	<u>Description</u>
10.49*	Novation Confirmation (#9233027), dated August 31, 2005, among Credit Suisse First Boston International, Cheniere Energy, Inc. and Cheniere LNG Holdings, LLC. (Incorporated by reference to Exhibit 10.1 of the Company's Quarterly Report on Form 10-Q for the quarter ended September 30, 2005 (SEC File No. 001-16383), filed on November 4, 2005)
10.50	International Swap Dealers Association, Inc. Master Agreement and Schedule, dated December 23, 2005, between Credit Suisse First Boston International and Cheniere LNG Holdings, LLC
10.51*†	Summary of Compensation to Non-Employee Directors. (Incorporated by reference to Exhibit 10.1 of the Company's Current Report on Form 8-K (SEC File No. 001-16383), filed on December 14, 2005)
10.52*†	Summary of Compensation for Executive Officers. (Incorporated by reference to Exhibit 10.1 of the Company's Current Report on Form 8-K (SEC File No. 001-16383), filed on January 5, 2006)
10.53	Agreement for Engineering, Procurement and Construction Services, dated February 21, 2006, between Cheniere Sabine Pass Pipeline Company and Willbros Engineers, Inc.
21	Subsidiaries of Cheniere Energy, Inc.
23.1	Consent of UHY Mann Frankfort Stein & Lipp CPAs, LLP
23.2	Consent of Hein & Associates LLP
23.3	Consent of Sharp Petroleum Engineering, Inc.
31.1	Certification by Chief Executive Officer required by Rule 13a-14(a) and 15d-14(a) under the Exchange Act
31.2	Certification by Chief Financial Officer required by Rule 13a-14(a) and 15d-14(a) under the Exchange Act
32.1	Certification by Chief Executive Officer pursuant to 18 U.S.C. Section 1350, as adopted pursuant to Section 906 of the Sarbanes-Oxley Act of 2002
32.2	Certification of Chief Financial Officer pursuant to 18 U.S.C. Section 1350, as adopted pursuant to Section 906 of the Sarbanes-Oxley Act of 2002
*	Incorporated by reference
†	Management contract or compensatory plan or arrangement
(c)	Freeport LNG Development, L.P. Financial Statements, for which Cheniere used the equity method of accounting for the period from December 1, 2002 to December 31, 2005, are filed as a part of this report beginning on page 124.



INDEX TO FINANCIAL STATEMENTS

**Freeport LNG Development, L.P. Audited Financial Statements**

<a href="#">Report of Independent Registered Public Accounting Firm</a>	125
<a href="#">Consolidated Balance Sheets</a>	126
<a href="#">Consolidated Statements of Operations</a>	127
<a href="#">Consolidated Statement of Partners' Capital (Deficit)</a>	128
<a href="#">Consolidated Statement of Cash Flows</a>	129
<a href="#">Notes to the Consolidated Financial Statements</a>	130

**REPORT OF INDEPENDENT REGISTERED PUBLIC ACCOUNTING FIRM**

To the Partners of  
Freeport LNG Development, L.P., a Limited Partnership  
Houston, Texas

We have audited the accompanying consolidated balance sheets of Freeport LNG Development, L.P., a Delaware limited partnership (a development stage limited partnership) and subsidiaries, as of December 31, 2005 and 2004, and the related consolidated statements of operations, changes in partners' capital (deficit) and cash flows for the years ending December 31, 2005, 2004 and 2003, and for the period from inception (December 1, 2002) through December 31, 2005. These financial statements are the responsibility of the Partnership's management. Our responsibility is to express an opinion on these financial statements based on our audits.

We conducted our audits in accordance with the standards of the Public Company Accounting Oversight Board (United States). Those standards require that we plan and perform the audits to obtain reasonable assurance about whether the financial statements are free of material misstatement. An audit includes examining, on a test basis, evidence supporting the amounts and disclosures in the financial statements. An audit also includes assessing the accounting principles used and significant estimates made by management, as well as evaluating the overall financial statement presentation. We believe that our audits provide a reasonable basis for our opinion.

In our opinion, the consolidated financial statements referred to above present fairly, in all material respects, the financial position of Freeport LNG Development, L.P. and subsidiaries, as of December 31, 2005 and 2004, and the results of their operations and their cash flows for the years ending December 31, 2005, 2004 and 2003, and for the period from inception (December 1, 2002) through December 31, 2005 in conformity with accounting principles generally accepted in the United States of America.

---

/s/ HEIN & ASSOCIATES LLP  
Hein & Associates LLP

Dallas, Texas  
February 16, 2006

[Table of Contents](#)

**FREEPORT LNG DEVELOPMENT, L.P.**  
**(A DEVELOPMENT STAGE LIMITED PARTNERSHIP)**  
**CONSOLIDATED BALANCE SHEETS**

	Years Ended December 31,	
	2005	2004
<b>ASSETS</b>		
<b>Current Assets:</b>		
Cash and cash equivalents	\$ 9,000	\$ 58,000
Cash restricted for construction, current general operations and other specified activities	379,341,000	37,866,000
Prepaid expenses	1,265,000	182,000
<b>Total current assets</b>	<b>380,615,000</b>	<b>38,106,000</b>
Office Equipment and Leasehold Improvements, net	1,614,000	144,000
Construction in Progress	246,351,000	9,728,000
Note Payable Offering Cost	6,959,000	—
Other Assets	736,000	448,000
<b>Total Assets</b>	<b>\$ 636,275,000</b>	<b>\$ 48,426,000</b>
<b>LIABILITIES AND PARTNERS' CAPITAL (DEFICIT)</b>		
<b>Current Liabilities:</b>		
Accounts payable and accrued liabilities	\$ 53,533,000	\$ 5,676,000
<b>Total current liabilities</b>	<b>53,533,000</b>	<b>5,676,000</b>
Notes Payable	595,766,000	48,041,000
Deferred Revenue and Other Deferred Credits	5,748,000	3,500,000
Commitments and Contingency (Notes 3 and 7)		
Partners' Capital (Deficit), including deficit accumulated during the development stage of \$36,056,000 and \$19,393,000, respectively	(18,772,000)	(8,791,000)
<b>Total Liabilities and Partners' Capital (Deficit)</b>	<b>\$ 636,275,000</b>	<b>\$ 48,426,000</b>

See accompanying notes to these consolidated financial statements.



[Table of Contents](#)

**FREEPORT LNG DEVELOPMENT, L.P.**  
**(A DEVELOPMENT STAGE LIMITED PARTNERSHIP)**  
**CONSOLIDATED STATEMENTS OF OPERATIONS**

	For the Years Ended December 31,			For the Period of Inception (December 1, 2002) through December 31, 2005
	2005	2004	2003	
Revenues	\$ —	\$ 10,000,000	\$ —	\$ 10,000,000
Expenses:				
Facility site rental and other site costs	4,798,000	820,000	573,000	6,191,000
Personnel and related costs	3,379,000	2,326,000	2,193,000	8,111,000
Engineering	139,000	2,394,000	2,419,000	5,200,000
Environmental and special studies	2,053,000	791,000	1,063,000	4,129,000
Purchase of limited partners pre-construction cost	—	—	5,000,000	5,000,000
Professional services	4,751,000	5,934,000	3,068,000	13,837,000
Other general and administrative costs	1,118,000	1,304,000	624,000	3,171,000
Total expenses	16,238,000	13,569,000	14,940,000	45,639,000
Operating Income (Loss)	(16,238,000)	(3,569,000)	(14,940,000)	(35,639,000)
Other Income (Expense):				
Interest income	612,000	8,000	—	620,000
Interest expense	(1,037,000)	—	—	(1,037,000)
Net Loss	\$ (16,663,000)	\$ (3,561,000)	\$ (14,940,000)	\$ (36,056,000)

See accompanying notes to these consolidated financial statements.

**FREEPORT LNG DEVELOPMENT, L.P.**  
*(A DEVELOPMENT STAGE LIMITED PARTNERSHIP)*  
**CONSOLIDATED STATEMENTS OF PARTNERS' CAPITAL (DEFICIT)**

	<u>General Partner</u>	<u>Limited Partners</u>	<u>Accumulated Deficit</u>	<u>Total Partners' Capital (Deficit)</u>
Balances, at Inception (December 1, 2002)	\$ —	\$ —	\$ —	\$ —
Net loss	—	—	(892,000)	(892,000)
Balances, at December 31, 2002	—	—	(892,000)	(892,000)
Capital contributions	—	10,390,000	—	10,390,000
Net loss	—	—	(14,940,000)	(14,940,000)
Balances, at December 31, 2003	—	10,390,000	(15,832,000)	(5,442,000)
Contributions	—	6,152,000	—	6,152,000
Withdrawals	—	(5,940,000)	—	(5,940,000)
Net loss	—	—	(3,561,000)	(3,561,000)
Balances, at December 31, 2004	—	10,602,000	(19,393,000)	(8,791,000)
Contributions	—	6,682,000	—	6,682,000
Net loss	—	—	(16,663,000)	(16,663,000)
Balances, at December 31, 2005	\$ —	\$ 17,284,000	\$ (36,056,000)	\$ (18,772,000)

See accompanying notes to these consolidated financial statements.

**FREEPORT LNG DEVELOPMENT, L.P.**  
**(A DEVELOPMENT STAGE LIMITED PARTNERSHIP)**  
**CONSOLIDATED STATEMENTS OF CASH FLOWS**

	For the Years Ended December 31,			For the Period from Inception (December 1, 2002) through 2005
	2005	2004	2003	
<b>Operating Activities:</b>				
Net loss	\$ (16,663,000)	\$ (3,561,000)	\$ (14,940,000)	\$ (36,056,000)
Adjustments to reconcile net loss to net cash used in operating activities:				
Depreciation	179,000	27,000	15,000	221,000
Changes in assets and liabilities:				
Prepays and other assets	(1,084,000)	36,000	(218,000)	(1,264,000)
Accounts payable and accrued liabilities	3,278,000	(1,398,000)	2,494,000	5,261,000
Due to limited partners	—	(2,501,000)	2,501,000	—
Deferred revenue	2,244,000	3,500,000	—	5,749,000
<b>Net cash used in operating activities</b>	<b>(12,046,000)</b>	<b>(3,897,000)</b>	<b>(10,148,000)</b>	<b>(26,089,000)</b>
<b>Investing Activities:</b>				
Purchase of property, equipment, and other assets	(1,649,000)	(469,000)	(165,000)	(2,284,000)
Construction in progress, net of increase in accounts payable related to construction in process	(191,290,000)	(6,040,000)	—	(197,330,000)
<b>Net cash used in investing activities</b>	<b>(192,939,000)</b>	<b>(6,509,000)</b>	<b>(165,000)</b>	<b>(199,614,000)</b>
<b>Financing Activities:</b>				
Note proceeds	383,000,000	—	—	383,000,000
Loan proceeds from COP	163,688,000	48,041,000	—	211,729,000
Contributions from partners	6,682,000	6,152,000	10,390,000	23,223,000
Payment of note offering cost	(6,959,000)	—	—	(6,959,000)
Withdrawals by partners	—	(5,940,000)	—	(5,940,000)
<b>Net cash provided by financing activities</b>	<b>546,411,000</b>	<b>48,253,000</b>	<b>10,390,000</b>	<b>605,053,000</b>
<b>Net Increase in Cash and Cash Equivalents</b>	<b>341,426,000</b>	<b>37,847,000</b>	<b>77,000</b>	<b>379,350,000</b>
Cash, Cash Equivalents and Restricted Cash, at beginning of period	37,924,000	77,000	—	—
<b>Cash, Cash Equivalents and Restricted Cash, at end of period</b>	<b>\$ 379,350,000</b>	<b>\$ 37,924,000</b>	<b>\$ 77,000</b>	<b>\$ 379,350,000</b>

See accompanying notes to these consolidated financial statements.

**FREEPORT LNG DEVELOPMENT, L.P.**  
**(A DEVELOPMENT STAGE LIMITED PARTNERSHIP)**  
**NOTES TO THE CONSOLIDATED FINANCIAL STATEMENTS**

**1. SIGNIFICANT ACCOUNTING POLICIES:**

*Business Activity*—Freeport LNG Development, L.P. (the “Partnership”) is in the process of developing, building and commercializing a liquefied natural gas (LNG) receiving and regasification facility on Quintana Island, near Freeport, Texas (the “Facility”). After construction is completed, the Partnership will own and operate the Facility. During 2004, FLNG Land, Inc. (Land), a wholly owned subsidiary, was formed to facilitate Phase 1 land related transactions. During 2005, Freeport LNG Expansion, L.P. and FLNG Storage, L.P., both wholly owned subsidiaries, were formed for the purpose of exploring adding additional capacity to the Facility (Phase 2) and exploring adding an underground storage facility (Storage). Also during 2005, FLNG Land II, Inc. (Land II), a wholly owned subsidiary, was formed to facilitate Phase 2 land related transactions.

*Principles of Consolidation*—The consolidated financial statements include the accounts of Freeport LNG Development, L.P. and its 100% owned subsidiaries. All intercompany accounts and transactions are eliminated in the consolidation.

*Use of Estimates*—The preparation of financial statements in conformity with accounting principles generally accepted in the United States of America requires management to make estimates and assumptions that affect certain reported amounts in the financial statements and accompanying notes. Actual results could differ from these estimates and assumptions.

*Cash and Cash Equivalents*—The Partnership considers all highly liquid investments with a maturity of three months or less when purchased to be cash equivalents.

Cash received from advances on the note payable to ConocoPhillips (COP) can only be used for construction and regular operations and cannot be used to fund any additional expansion studies or be used to pay expenses that were incurred prior to when the Partnership obtained Federal Energy Regulatory Commission (“FERC”) approval for the construction of Phase 1 of the Facility.

Cash received from the notes payable to institutional investors is restricted and can only be used for additional Phase 1 costs, expansion studies or expansion construction, storage construction, and certain other disbursements.

*Property, Plant and Equipment*—Property, plant and equipment are stated at cost. Depreciation is computed using the straight-line method over the estimated useful lives of the assets for financial reporting purposes. Expenditures for major renewals and betterments that extend the useful lives are capitalized. Expenditures for normal maintenance and repairs are expensed as incurred. When assets are sold or abandoned, the cost of the assets sold or abandoned and the related accumulated depreciation will be eliminated from the accounts, and any gains or losses will be charged or credited to other income (expense) of the respective period. The estimated useful lives by classification are as follows:

Office Equipment	5 years
Leasehold Improvements	15 years

*Construction in Progress*—Construction in progress through December 31, 2005 relates to engineering, land, acquisition, title work, and other direct costs related to Phase 1 construction of the Facility, which were

**FREEPORT LNG DEVELOPMENT, L.P.**  
**(A DEVELOPMENT STAGE LIMITED PARTNERSHIP)**  
**NOTES TO THE CONSOLIDATED FINANCIAL STATEMENTS—(Continued)**

incurred after the Partnership obtained FERC approval and closed on the related construction loan, and physical assets added to Phase 1 during the construction that were needed in order to allow a potential Phase 2 expansion to be built at a later time.

*Revenue Recognition*—Revenues will be recognized for terminal use fees as they are earned from the regasification process. Revenue from capacity reservations are generally deferred.

The Partnership also recognized revenue from a transaction in 2004 when it provided engineering and design studies to ConocoPhillips. In connection with this sale, the Partnership also agreed to reserve a specific amount of capacity for ConocoPhillips.

*Concentrations of Credit Risk and Other Concentrations*—Although held in nationally recognized financial institutions, substantially all of the Partnership's cash balances are in excess of the FDIC insurance limits. As discussed in Note 4, ConocoPhillips has significant involvement with the Partnership.

*Income Taxes*—The Partnership files its Federal income tax return as a partnership under the Internal Revenue Code. In lieu of corporate income taxes, the partners of the Partnership are taxed on their proportionate share of the Partnership's taxable income. Accordingly, no provision or liability has been recognized for federal income tax purposes for those periods, as taxes are the responsibility of the individual partners of the Partnership.

Income taxes are provided for the Partnership's subsidiaries that are C-Corporations in accordance with Statement of Financial Accounting Standards No. 109 "Accounting for Income Taxes". A deferred tax asset or liability is recorded for all temporary differences between income for financial statement purposes and income for tax purposes as well as operating loss carry forwards. Deferred tax expense (or benefit) results from the net change during the year of deferred tax assets and liabilities.

The net deferred tax assets for these subsidiaries were approximately \$1,020,000 and \$130,000 at December 31, 2005 and 2004, respectively before the valuation allowance. The net deferred tax asset has been reduced to zero in both periods after consideration of the valuation allowance. A valuation allowance is recorded when, in the opinion of management, it is likely that some portion of the deferred tax asset will not be realized. Deferred taxes are adjusted for the effects of changes in tax laws and rates. No income taxes were paid in 2003, 2004 or 2005.

**2. DEVELOPMENT STAGE OPERATIONS:**

The Partnership was formed December 1, 2002. Through June 2004, operations were devoted to preconstruction costs such as obtaining approvals from FERC, obtaining the appropriate leases and permits, completing the engineering and environmental studies necessary for further development of the Facility, and obtaining financing to construct the Facility.

In June 2004, the Partnership obtained FERC approval for the Facility subject to satisfaction of certain conditions. The conditions were satisfied and FERC issued approval to begin construction in January 2005. Construction began on January 17, 2005. The construction of Phase 1 is expected to be completed in the first quarter of 2008.

The Partnership is also pursuing research and development for possible expansion of the Facility, the construction of an underground storage facility, and other opportunities.

**FREEPORT LNG DEVELOPMENT, L.P.**  
**(A DEVELOPMENT STAGE LIMITED PARTNERSHIP)**  
**NOTES TO THE CONSOLIDATED FINANCIAL STATEMENTS—(Continued)**

**3. LIQUIDITY AND CONTINUED OPERATIONS:**

The Partnership will ultimately need to complete construction of the Facility and operate it profitably. There is significant construction which needs to be completed, and start up of Phase 1 of the Facility is expected in 2008.

Notwithstanding the foregoing, the Partnership believes it will continue as a going-concern based on favorable results related to the engineering studies, having secured all permits and government approvals required for Phase 1, the strong financial backing of its partners and future customers, its success in commercializing the expected available capacity, and its current financing obtained from ConocoPhillips and institutional investors.

**4. AGREEMENT WITH CONOCOPHILLIPS:**

The Partnership's general partner ("Freeport LNG GP Inc." or "Freeport GP"), and ConocoPhillips have executed an omnibus agreement. This agreement governs several transactions among the entities. The agreement was modified in the fourth quarter of 2005. The agreement, among other things, governs the following:

- ConocoPhillips agreed to pay the Partnership \$10,000,000 for specific engineering and design studies, which occurred in January 2004. The Partnership recorded the payment as revenue in 2004.
- ConocoPhillips agreed to loan a substantial majority of the Facility's anticipated construction costs, including interest during the construction phase. The debt service under this loan will be fully serviced by the ConocoPhillips Terminal Use Agreement ("TUA"). The Partnership made loan draws of approximately \$202,000,000 against this construction loan and expects to make additional loan draws in excess of \$400,000,000 prior to completion of construction of the Facility. Additional draws were made against the loan subsequent to December 31, 2005.
- ConocoPhillips purchased 50% of the stock of Freeport LNG GP for \$9,000,000 from the principal investor of Freeport LNG GP. After the purchase of the stock, ConocoPhillips and the principal investor of Freeport LNG GP each appointed three persons to a board which manages the construction and will manage operation of the Facility.
- ConocoPhillips agreed to a TUA which will govern the terms under which LNG is processed and will reserve a specified capacity.

**5. DEFERRED REVENUE:**

The Partnership received \$3,500,000 from ConocoPhillips in 2004 and \$1,500,000 from MC Global Gas Corporation in 2005 to reserve specific capacities that are expected to be available if the Partnership completes a potential Phase 2 expansion of the plant. This revenue will not be recognized unless a Phase 2 expansion is completed. The Partnership is still researching the feasibility of Phase 2, and at this time, it is uncertain when, or if, Phase 2 construction or operations will begin.

**6. NOTES PAYABLE:**

*ConocoPhillips*—The Partnership has entered into an agreement with ConocoPhillips to provide financing to construct the Facility. ConocoPhillips has agreed to finance the first \$460,000,000 of construction cost, including \$10,000,000 in support of any channel widening efforts undertaken by the Brazos River Harbor Navigation District (the "Port"), and has agreed to provide financing up to 50% of any additional supplemental

**FREEPORT LNG DEVELOPMENT, L.P.**  
**(A DEVELOPMENT STAGE LIMITED PARTNERSHIP)**  
**NOTES TO THE CONSOLIDATED FINANCIAL STATEMENTS—(Continued)**

costs incurred. The Partnership has drawn approximately \$202,000,000 as of December 31, 2005. The interest rate on the note is 8%. Interest totaling \$9,368,000 and \$420,000 at December 31, 2005 and 2004, respectively, has been capitalized and all interest has been accrued and is included in notes payable as of December 31, 2005. Repayments on this loan will not begin until the Facility is constructed and operating. The loan is collateralized by all of the Phase 1 assets of the Partnership.

*Institutional Investors*—In December 2005 the Partnership completed a \$383,000,000 private placement of notes payable. The purchasers were institutional investors. The notes bear an interest rate of 6.5%, which is subject to up to two 50 basis point upward adjustments, based on the creditworthiness of the customers. All interest on the notes was accrued at December 31, 2005. The notes begin amortizing in 2010, with final payment due in December 2015. The use of the proceeds is restricted for the remaining 50% of any additional Phase 1 supplemental costs (as described with ConocoPhillips above) and for certain other expansion, development or operational activities. In conjunction with the note placement, the Partnership capitalized approximately \$6,959,000 of note offering costs, which are being amortized over the term of the notes. Amortization expense for 2005 was not material. The loan is collateralized by the Dow Terminal Use Agreement, by the underground storage assets, if constructed, of the Partnership and by a second lien on all Phase 1 assets of the Partnership.

**7. COMMITMENTS:**

The Partnership has entered into lease agreements with the Port for the lease of the land on which the Facility will be constructed and areas around the Facility. The leases will terminate in 2033, with six options to renew the leases for an additional 10 years for each option. The lease agreements require \$2,300,000 in payments each year. The lease payments will also increase based on increases in the Consumer Price Index (“CPI”) from year to year.

Additionally, the leases provide that the Partnership will guarantee thru-put fees of \$1,250,000 per year (subject to increase for the CPI index) to be received by the Dock Facilities operated by the Port from carriers shipping LNG to the Facility. This guarantee is expected to begin in 2008.

The Partnership has entered into a lease agreement in 2005 with Pinto Energy Partners, L.P. for the lease of land on which a storage facility may be constructed. The lease will terminate in 2033, with six options to renew for an additional 10 years for each option. Base rent is \$250,000 until March 1, 2010. If construction of the storage facility has not begun prior to March 1, 2010, base rent will increase to \$750,000 until construction begins. Based on the projected beginning of construction and the projected completion date, base rent will increase between \$400,000 and \$1,400,000. If the storage facility is completed (beginning no earlier than March 1, 2010), rent will increase to \$2,000,000 per year. All amounts due under the lease are subject to annual adjustments based on the CPI. The Partnership also can make a one time payment of \$2,500,000 between March 1, 2010 and April 30, 2010 to terminate the lease (adjusted for CPI), if construction has not started.

The Partnership office lease has a base rent of \$194,000 per year with an estimated additional rent of \$130,000 which will be adjusted by the landlord each calendar year. Additional rent is to reimburse taxes and expenses incurred by the landlord which the Partnership is obligated to pay based on the terms of the lease. The term of the lease is 100 months beginning on July 1, 2005.

**FREEPORT LNG DEVELOPMENT, L.P.**  
**(A DEVELOPMENT STAGE LIMITED PARTNERSHIP)**  
**NOTES TO THE CONSOLIDATED FINANCIAL STATEMENTS—(Continued)**

The following table presents the future minimum lease payments due under the leases and ignoring any increases related to the CPI index, the thru-put guarantee, or increases based on construction of the storage facility:

	Land	Land-Storage	Office
2006	\$ 2,300,000	\$ 250,000	\$ 324,000
2007	2,300,000	250,000	324,000
2008	2,300,000	250,000	324,000
2009	2,300,000	250,000	324,000
2010	2,300,000	250,000	324,000
Thereafter	50,600,000	17,000,000	974,000
	<u>\$ 62,100,000</u>	<u>\$ 18,250,000</u>	<u>\$ 2,594,000</u>

Rent expense and related costs were \$2,652,000, \$820,000 and \$573,000 for the years ended December 31, 2005, 2004 and 2003, respectively.

*Employment Agreements*—The Partnership has employment agreements with six key managers of the Partnership. The agreements define target annual variable compensation levels, vesting in profits participation, and define the duration of the employment obligation. The Partnership has accrued and, subsequent to December 31, 2005, paid all annual variable compensation obligations due under these agreements. The initial employment term has expired for a portion of the six employment agreements and the related employees are now “at will” employees with no Partnership obligation other than those associated with vested profits participation, if any. Because the Facility has not begun operation, the profits participation obligation, if any, cannot be determined. A maximum remaining salary obligation of not more than \$300,000 remains under the portion of the agreements for which the initial term has not expired.

*Related Parties*—In December 2004, the Partnership entered into a consulting agreement with an affiliate of the principal investor of Freeport LNG GP to provide for chief executive officer services. The agreement requires yearly payments of \$500,000 and reimbursement for travel and other expenses. In 2005 the Partnership expensed \$500,000 for the consulting services and \$635,000 for reimbursement of travel and other expenses.

*Capacity Reservations*—One of the Partnership’s limited partners, Freeport LNG Investments LLLP, has entered into an agreement whereby it borrowed \$5,000,000 from The Dow Chemical Company (“Dow”). In connection with this agreement, Freeport LNG Investments LLLP invested the proceeds of the loan as a capital contribution to the Partnership and the Partnership agreed to reserve a stipulated capacity at the Facility for Dow. The Dow Capacity Reservation and the ConocoPhillips TUA are expected to fully reserve substantially all of the Facility’s anticipated Phase 1 capacity.

*Turn-key Construction Contract*—The Partnership has a turn-key construction contract for Phase 1 and for certain work that will facilitate expansion of the Facility with a fixed price of \$577,798,000, which includes all change orders agreed to through December 31, 2005. It is reasonably possible that additional change orders will be executed, increasing the cost of the Facility.

*Phase 2*—The Partnership is evaluating the possibility of expanding the vaporization capacity of the Facility and evaluating the feasibility of constructing and operating an underground natural gas storage facility near Stratton Ridge, Texas. In May 2005 the Partnership filed an application with FERC to expand the permitted



[Table of Contents](#)

**FREEPORT LNG DEVELOPMENT, L.P.**  
**(A DEVELOPMENT STAGE LIMITED PARTNERSHIP)**  
**NOTES TO THE CONSOLIDATED FINANCIAL STATEMENTS—(Continued)**

capacity of the plant to a total capacity of 4.0 BCFD. Approval is pending review by FERC. In conjunction with the possible expansion, the Partnership has submitted applications for permits from other governing agencies including the Texas Commission on Environmental Quality, the U.S Army Corp of Engineers, and the U.S Coast Guard. Subsequent to December 31, 2005, the Texas Railroad Commission has approved construction of the underground storage facility. The feasibility of both the expansion of the Facility and construction of an underground storage facility are ongoing.

**8. OFFICE EQUIPMENT AND LEASEHOLD IMPROVEMENTS:**

Property and equipment consists of:

	Years Ended December 31,	
	2005	2004
Office equipment	\$ 440,000	\$ 142,000
Leasehold improvements	1,395,000	44,000
Property and equipment	1,835,000	186,000
Less: accumulated depreciation	(221,000)	(42,000)
Total property and equipment, net	\$ 1,614,000	\$ 144,000

**9. ACCOUNTS PAYABLE AND ACCRUED LIABILITIES:**

Accounts payable and accrued liabilities consist of the following:

	Years Ended December 31,	
	2005	2004
Employee bonuses	\$ 572,000	\$ 489,000
Engineering and study costs	1,069,000	275,000
Professional fees	1,730,000	644,000
Investment banking advisor fees	14,000	117,000
Construction related costs	49,308,000	3,688,000
Other accrued liabilities and payables	840,000	463,000
Total accounts payable and accrued liabilities	\$ 53,533,000	\$ 5,676,000

**10. SUBSEQUENT EVENT:**

Subsequent to December 31, 2005, the Partnership continued to construct Phase 1 and continued to borrow funds from ConocoPhillips. Additional research and development expenditures were made subsequent to December 31, 2005 for development activities on the possible Phase 2 expansion and possible storage facility.

**CHENIERE ENERGY, INC.**  
**2003 STOCK INCENTIVE PLAN**  
**ADDENDUM - FRANCE**

---

**The provisions of this Addendum apply to French Options and French Restricted Stock (as defined below) granted under the 2003 CHENIERE ENERGY, INC. Stock Incentive Plan (the “Plan”) to French Eligible Employees of the Company (as defined below).**

**These provisions supplement and supersede (where applicable) the provisions of the Plan with respect to French Options and French Restricted Stock. In the event of a conflict or inconsistency between the terms and provisions of the Plan and the express provisions of this Addendum, the provisions of this Addendum shall govern and control the grant of French Options and French Restricted Stock under the Plan.**

**This Addendum shall be administered by the Committee in accordance with Section 1.3 of the Plan.**

**Capitalised terms not defined herein shall have the meaning attributed to them in the Plan.**

French Option means an Option granted to a French Eligible Employee under this Addendum.

French Restricted Stock means a Restricted Stock granted to a French Eligible Employee under this Addendum.

The Company may grant a French Option over shares of Common Stock (the “Shares”) or a French Restricted Stock to any person who is eligible to be granted an Option or a Restricted Stock under the Plan and subject to the additional terms and conditions in this Addendum.

Notwithstanding the definition of Employee, Director and Consultant in the Plan, French Options and Restricted Stock may only be granted to individuals, resident in France for the purposes of taxation at the date of grant, who are employees, Chairman of the Board (*Président du conseil d’administration*), Managing Directors (*Directeurs généraux*), members of the Executive Board (*membres du Directoire*) and Managers (*gérants*) of the Company or a company of which at least 10% of the capital is controlled directly or indirectly by the Company (the “French Eligible Employee(s)”).

Notwithstanding any other provision of the Plan, French Options and French Restricted Stock granted to any French Eligible Employees already owning, or owning as a result of such grant, Shares representing 10% or more of the Company’s capital shall be deemed not to have been granted pursuant to this Addendum.

Notwithstanding any other provision of the Plan, no French Options or French Restricted Stock may be granted later than 38 months from the date on which this Addendum is adopted.

The French Eligible Employee and its employer shall comply with the filing requirements provided for by French tax law.

---

**1. French Options**

- 1.1 The aggregate number of French Options granted and not yet exercised shall not, at any point in time, give right to subscribe for a number of Shares exceeding one third of the share capital of the Company. For the avoidance of doubt, Shares allocated under this Addendum shall be taken into account for the purposes of determining the maximum number of Shares subject to the Plan.
- 1.2 Notwithstanding any other provision of the Plan, if and so long as the Shares are admitted to trading on a regulated market, any Option providing for an Exercise Price per Share at the date of the grant of the Option which is less than 95% of the arithmetical average of the market value of the Share over the 20 daily sessions preceding the date of grant shall be deemed not to have been granted under this Addendum. For the purposes of this Rule, 'market value' shall be the middle market quotation of the Share.
- 1.3 Notwithstanding any other provision of the Plan, if and so long as the Shares are admitted to trading on a regulated market, and the Shares are to be transferred rather than issued to the French Eligible Employees:
- (i) such Shares shall not have been held by the Company for a period exceeding one year prior to the grant of the French Option; and
  - (ii) the Exercise Price per Share shall not be less than 95% of the average purchase price of the Share held by the Company for the purposes of granting French Options under this Addendum.
- 1.4 Notwithstanding any other provision of the Plan, no Option can be granted to a French Eligible Employee before:
- (A) twenty daily sessions have elapsed after the date of issue of any dividend warrants or of the allotment of any further shares or debentures by way of dividends;
  - (B) within the 10 trading days preceding and following the date on which the consolidated or annual accounts of the Company are made public;
  - (C) during the period of time between the date the Company becomes aware of information which would have a significant impact on the price of the Shares and the 10 trading days following the date upon which such information is made public.
- 1.5 Notwithstanding any other provision of the Plan, the Exercise Price for French Eligible Employees and/or the number of French Options referred to above shall be adjusted upon the occurrence of the events specified in Article L. 225-181 of the French Commercial Code (*Code de commerce*) – hereafter the "FCC" – and in accordance therewith.
- 1.6 The Shares resulting, transferred or allotted on the exercise of a French Option shall be registered in the name of the French Eligible Employee or registered in a securities account opened in the name of the Eligible Employee.

- 
- 1.7 A French Option shall be exercisable at such time or times as the Committee in its discretion may determine at the time such French Option is granted, provided however that if a French Option becomes exercisable before the expiry of the fourth year from the date of grant, the French Eligible Employee shall not be entitled to dispose of the Shares resulting, transferred or allotted on the exercise of a French Option before the expiry of the fourth year from the date of grant. In the event of a modification to Article 163 bis C of the French Tax Code (*Code général des impôts*) which has the effect of reducing or extending the said period of four year provided therein, the period of four year mentioned above shall be replaced by a period equal to the new period which will be set out in Article 163 bis C of the French Tax Code thus modified as from the effective date of such legislative change.
- 1.8 However, the Shares resulting, transferred or allotted on the exercise of a French Option may be disposed of before the expiry of the fourth anniversary of the date of grant for one of the following reasons:
- (A) disability (as defined by Article L. 341-1 of the French Social Security Code *Code de sécurité sociale*);
  - (B) involuntary retirement, provided that the exercise takes place at least three months prior to the date of the retirement;
  - (C) death of the French Eligible Employee;
  - (D) dismissal or redundancy at the request of the Company, provided that exercise has taken place at least three months prior to the notification of termination.
- 1.9 Unless otherwise determined by the Committee, the maximum number of French Options exercisable by the French Eligible Employee as a result of the occurrence of one of the events mentioned in (A) to (D) of Section 1.8 of this Addendum shall be limited to the aggregate amount of the options vested in accordance with the terms determined by the Committee at the time the French Option is granted.
- 1.10 Any French Option which was not vested at the date of occurrence of one of the events mentioned in (A) to (D) of Section 1.8 of this Addendum shall be forfeited back to the Company.
- 1.11 On the death of a French Eligible Employee, at a time when the French Option has not lapsed, the French Option may not be exercised by the heirs of the French Eligible Employee later than 6 months following the date of the death.
- 1.12 Notwithstanding any other provision of the Plan, the French Options may not be disposed of by any French Eligible Employee before the French Option has been exercised.

---

**2. French Restricted Stock**

- 2.1 Notwithstanding any other provision of the Plan, the aggregate number of French Restricted Stock granted shall not, at any point in time, give right to subscribe for a number of Shares exceeding 10% of the share capital of the Company. For the avoidance of doubt, Shares allocated under this Addendum shall be taken into account for the purposes of determining the maximum number of Shares subject to the Plan.
- 2.2 Notwithstanding any other provision of the Plan, French Restricted Stock shall vest upon expiry of a period of two years from the date of grant (or such longer period as the Committee may determine), being currently the minimum vesting period provided by Article L. 225-197-1 of the FCC. In the event of a modification to Article L 225-197-1 of the FCC which has the effect of reducing or extending the said minimum period provided therein, the two-year period shall be replaced by a period equal to the new period which will be set out in the L 225-197-1 of the FCC thus modified as from the effective date of such legislative change.
- 2.3 Notwithstanding any other provision of the Plan, an Award of French Restricted Stock shall be personal to the French eligible employee to whom it is made and shall not be transferable.
- 2.4 Notwithstanding any other provision of the Plan, all French Restricted Stock delivered upon vesting into the name of the French Eligible Employee shall not be disposed of by him for a period of at least two years as from the vesting date (or any such longer period as the Committee may require), being currently the minimum holding period provided by Article L. 225-197-1 of the FCC. In the event of a modification to Article L 225-197-1 of the FCC which has the effect of reducing or extending the said minimum period provided therein, the two-year period shall be replaced by a period equal to the new period which will be set out in the L 225-197-1 of the FCC thus modified as from the effective date of such legislative change.
- 2.5 Notwithstanding any other provision of the Plan, as from the date of expiry of the holding period, as defined under Section 2.4 of this Addendum, the French Eligible Employee will be entitled to dispose of the Shares at any time, provided however that the Shares may not be disposed of:
- (A) within 10 trading days preceding AND following the date of publication of the consolidated accounts of the Company or in the absence of such consolidated accounts, the annual accounts; and
- (B) during the period of time comprised BETWEEN the date on which the management of the Company becomes aware of any information which would have a significant impact on the price of the Shares if it were made public and the 10 trading days following the date on which such information is made public.
- 2.6 On the death of a French Eligible Employee, at a time when the French Restricted Stock has not vested, the French Restricted Stock may not be allocated to the heirs of the French Eligible Employee later than 6 months following the date of the death.

**SCHEDULE D-2**  
**UNILATERAL CHANGE ORDER FORM**

**PROJECT NAME:** Sabine Pass LNG Receiving,  
Storage and Regasification Terminal

**CHANGE ORDER NUMBER:** SP/BE-001

**OWNER:** Sabine Pass LNG, L.P.

**DATE OF CHANGE ORDER:** January 18, 2005

**CONTRACTOR:** Bechtel Corporation

**Increase Sendout Pressure to 1440 PSIG**

**DATE OF AGREEMENT:** December 18, 2004

**You are hereby directed to make the following additions or modifications to, or deductions from, the Work***(attach additional documentation if necessary)*

Increase sendout pressure of the Natural Gas as measured at the back-pressure control valve located just upstream of the Master Meter from 1250 psig to 1440 psig. Piping from outlet of the high pressure sendout pumps through to and including the last flange of the LNG terminal shall be ANSI Class 900 lb. Temperature of sendout gas and all other requirements of the Minimum Acceptance Criteria and the Performance Guarantees as specified in Attachment S and Attachment T of the Agreement shall be remain the same.

Contractor shall proceed with design solely on the basis of a 1440 psig sendout pressure and prepare the required documentation, including a completed Schedule D-3 in accordance with Article 6.1A of the Agreement.

Compensation for the changes specified in this Change Order is on a time and materials basis as provided in Section 6.1C and 6.2D of the Agreement.

Contractor shall commence with the performance of the change(s) described above **on January 18, 2005.**

This Change Order is signed by Owner's duly authorized representative.

/s/ Ed Lehotsky  
Owner Representative  
Ed Lehotsky

January 18, 2005  
Date of signing

**SCHEDULE D-1**  
**CHANGE ORDER FORM**

**PROJECT NAME:** Sabine Pass LNG Receiving,  
Storage and Regasification Terminal

**CHANGE ORDER NUMBER:** SP/BE-002

**DATE OF CHANGE ORDER:** February 7, 2005

**OWNER:** Sabine Pass LNG, L.P.

**CONTRACTOR:** Bechtel Corporation

**DATE OF AGREEMENT:** December 18, 2004

---

**The Agreement between the Parties listed above is changed as follows:**

---

**Adjustment to Contract Price**

The original Contract Price was	\$ 646,936,000
Net change by previously authorized Change Orders (#_____)	\$ 0
The Contract Price prior to this Change Order was	\$ 646,936,000
The Contract Price will be <u>increased</u> by this Change Order in the amount of	\$ 1,500,000
The new Contract Price including this Change Order will be	\$ 648,436,000

**Adjustment to dates in Project Schedule**

The following dates are modified (*list all dates modified; insert N/A if no dates modified*):

The Target Bonus Date will be unchanged.

The Target Bonus Date as of the date of this Change Order therefore is 1,095 Days following NTP

The Guaranteed Substantial Completion Date will be unchanged.

The Guaranteed Substantial Completion Date as of the date of this Change Order therefore is 1,247 Days following NTP

Adjustment to other Changed Criteria: The Tank Subcontract will be awarded to MHI/MSI

Adjustment to Milestone Payment Schedule, Schedule C-1:

- Milestone Number 2.02, LNG Tank Subcontract Awarded, will be increased by \$1,500,000 from \$3,234,680 to \$4,734,680. The entire \$1,500,000 increase will be provided as an increased payment to the LNG Tank Subcontractor MHI/MSI
- Milestone Number 4.03, "LNG Tank test piling started," will be decreased by \$350,000 from \$3,234,680 to \$2,784,680 to offset the payment to MHI/MSI for LNTP as described in the Adjustment to Payment Schedule, Schedule C-2 below

Adjustment to Monthly Payment Schedule, Schedule C-2:

- Payment for Month #2, Feb-05, will be increased by \$350,000 from \$2,005,502 to \$2,355,502. The entire \$350,000 increase will be provided as a payment for Limited Notice to Proceed to the LNG Tank Subcontractor MHI/MSI

Adjustment to Minimum Acceptance Criteria: None



---

Adjustment to Design Basis: None

Other adjustments to liability or obligation of Contractor or Owner under the Agreement:

MHI/MSI shall be awarded the Tank Subcontract

This Change Order **shall** constitute a full and final settlement and accord and satisfaction of all effects of the change as described in this Change Order upon the Changed Criteria and shall be deemed to compensate Contractor fully for such change.

Upon execution of this Change Order by Owner and Contractor, the above-referenced change shall become a valid and binding part of the original Agreement without exception or qualification, unless noted in this Change Order. Except as modified by this and any previously issued Change Orders, all other terms and conditions of the Agreement shall remain in full force and effect. This Change Order is executed by each of the Parties, duly authorized representatives.

/s/ Charif Souki

\* Charif Souki  
Chairman

/s/ C. Asok Kumar

Contractor

C. Asok Kumar

Name

Project Director

Title

February 7, 2005

Date of Signing

Date of Signing

/s/ Keith Meyer

\* Keith Meyer  
President

February 7, 2005

Date of Signing

/s/ Ed Lehotsky

\* Ed Lehotsky  
Owner Representative

February 7, 2005

Date of Signing

\* Required Owner signature

**SCHEDULE D-2**  
**UNILATERAL CHANGE ORDER FORM**

**PROJECT NAME:** Sabine Pass LNG Receiving,  
Storage and Regasification Terminal

**CHANGE ORDER NUMBER:** SP/BE-003

**DATE OF CHANGE ORDER:** January 25, 2005

**OWNER:** Sabine Pass LNG, L.P.

**CONTRACTOR:** Bechtel Corporation

**DATE OF AGREEMENT:** December 18, 2004

---

**You are hereby directed to make the following additions or modifications to, or deductions from, the Work**

Contractor shall delete the High Pressure Compressor from its scope (included in the reimbursable scope) and instead install only the tie-ins and space necessary for a "Future" diesel driven compressor. All other requirements of the Agreement shall remain the same.

Discussions with FERC indicate that they feel a High Pressure Sendout Compressor is required in case the LNG Tanks are de-inventoried in order to "mothball" the LNG Terminal. Since this is a very remote possibility, and since venting of this gas is neither a safety nor environmental concern, Owner will present formal arguments to FERC to delete this requirement. Failing this, Owner will propose to FERC that only connections and space are provided for this compressor. If the Terminal is mothballed, Owner will purchase or rent a portable compressor(s), heater, and other equipment, install it, and accomplish the required transfer to the pipeline.

Contractor shall proceed with design as described above and prepare the required documentation, including a completed Schedule D-3 in accordance with Article 6.1A of the Agreement.

Contractor shall commence with the performance of the change(s) described above **on January 25, 2005**.

This Change Order is signed by Owner's duly authorized representatives.

/s/ Charif Souki

\* Charif Souki  
Chairman

February 11, 2005

Date of Signing

/s/ Keith Meyer

\* Keith Meyer  
President

February 9, 2005

Date of Signing

/s/ Ed Lehotsky

\* Ed Lehotsky  
Owner Representative

January 25, 2005

Date of Signing

\* Required Owner signature

**SCHEDULE E-1  
CHANGE ORDER FORM**

**PROJECT NAME:** Sabine Pass LNG Receiving,  
Storage and Regasification Terminal 1001

**CHANGE ORDER NUMBER:** SP/BE-004

**DATE OF CHANGE ORDER:** 03/22/2005

**OWNER:** Sabine Pass LNG, L.P.

**CONTRACTOR:** Bechtel Corporation

**DATE OF AGREEMENT:** December 18, 2004

---

**The Agreement between the Parties listed above is changed as follows:** Approval of Change Orders via Schedule D-1 and D-2 (Rev. 1) of the EPC Agreement will require the signatures of both Messrs. Charif Souki and Keith Meyer, in addition to the designated Owner Representative, Ed Lehotsky. This requirement will not apply to any other correspondence under the EPC Agreement.

A revised copy of Schedules D-1 and D-2 is attached reflecting the above change.

---

**Adjustment to Contract Price**

The original Contract Price was	\$ 646,936,000
Net change by previously authorized Change Orders (#SP/BE-002)	\$ 1,500,000
The Contract Price prior to this Change Order was	\$ 648,436,000
The Contract Price will be unchanged by this Change Order in the amount of	\$ 0
The new Contract Price including this Change Order will be	\$ 648,436,000

**Adjustment to dates in Project Schedule**

The following dates are modified (*list all dates modified; insert N/A if no dates modified*):

The Target Bonus Date will be unchanged.

The Target Bonus Date as of the date of this Change Order therefore is 1,095 Days following NTP.

The Guaranteed Substantial Completion Date will be unchanged.

The Guaranteed Substantial Completion Date as of the date of this Change Order therefore is 1,247 Days following NTP.

Adjustment to other Changed Criteria: None

Adjustment to Payment Schedule: None

Adjustment to Minimum Acceptance Criteria: None

Adjustment to Performance Guarantees: None

Adjustment to Design Basis: None

Other adjustments to liability or obligation of Contractor or Owner under the Agreement: N/A

---

This Change Order **shall** constitute a full and final settlement and accord and satisfaction of all effects of the change as described in this Change Order upon the Changed Criteria and shall be deemed to compensate Contractor fully for such change.

Upon execution of this Change Order by Owner and Contractor, the above-referenced change shall become a valid and binding part of the original Agreement without exception or qualification, unless noted in this Change Order. Except as modified by this and any previously issued Change Orders, all other terms and conditions of the Agreement shall remain in full force and effect. This Change Order is executed by each of the Parties' duly authorized representatives.

/s/ Charif Souki  
\* Charif Souki  
Chairman

\_\_\_\_\_  
Date of Signing

/s/ Keith Meyer  
\* Keith Meyer  
President

March 29, 2005  
Date of Signing

/s/ Ed Lehotsky  
\* Ed Lehotsky  
Owner Representative

\_\_\_\_\_  
Date of Signing

\* Required Owner signature

/s/ C. Asok Kumar  
Contractor

C. Asok Kumar  
Name

Project Director  
Title

March 31, 2005  
Date of Signing

**SCHEDULE D-1  
CHANGE ORDER FORM**

**PROJECT NAME:** Sabine Pass LNG Receiving,  
Storage and Regasification Terminal

**CHANGE ORDER NUMBER:** SP/BE-005

**DATE OF CHANGE ORDER:** 3/23/2005

**OWNER:** Sabine Pass LNG, L.P.

**CONTRACTOR:** Bechtel Corporation

**DATE OF AGREEMENT:** December 18, 2004

---

**The Agreement between the Parties listed above is changed as follows:**

On March 14, 2005, Owner requested Contractor to delay placement of the following insurance coverages required under Section 7.1.B, Section 9.1 and Attachment O in the EPC Agreement as part of its effort to reduce the Actual Insurance Costs: the insurance coverages required under Section 1A.5, 1A.6, 1A.7, 1A.8, 1A.11, 1A.12 and 1A.14 of Attachment O; the increase in the coverage under Section 1A.4 of Attachment O from minimum limits of U.S.\$10,000,000 to U.S.\$100,000,000 each occurrence and aggregate; and certain insurance coverages specified in Section 1A.9 and 1A.10 of Attachment O, as specified in greater detail below.

In accordance with Attachment O, Section 1.B, Contractor shall procure the coverages specified in Sections 1A.4 (having the minimum limits of U.S. \$100,000,000 for each occurrence and aggregate), 1A.5, 1A.6, 1A.7, 1A.8, 1A.11, 1A.12 and 1A.14 of Attachment O no later than June 3, 2005.

In accordance with Attachment O, Section 1.B, Contractor shall procure a portion of the coverages required under Sections 1A.9 and 1A.10 of Attachment O no later than NTP or as soon as reasonably possible thereafter. The Parties agree that the portion of insurance under Section 1A.9 and 1A.10 which is required to be procured by NTP or as soon as reasonably possible thereafter is specified in the attached term sheet. The difference in coverages between (a) the coverages specified in Section 1A.9 and 1A.10 of Attachment O and (b) the coverages specified in the attached term sheet shall be procured by Contractor no later than June 3, 2005. The terms and coverages specified in the attached term sheet are only approved for the purpose of determining the coverages required to be provided up to June 3, 2005.

Contractor's obligation to notify and document the Actual Insurance Cost in Section 7.1.B of the Agreement shall be extended to June 3, 2005.

Owner understands that there is the potential that as a result of delayed purchase of those Project Insurances specified above that: 1) the final costs for the Project Insurances may increase beyond what would be obtainable at NTP, and 2) certain coverages required in the Project Insurances may become unavailable due to changes in the insurance market. The cost of the Project Insurances payable by Owner to Contractor shall be as provided under Section 7.1B.

---

**Adjustment to Contract Price**

The original Contract Price was	\$ 646,936,000
Net change by previously authorized Change Orders (#SP/BE-002)	\$ 1,500,000
The Contract Price prior to this Change Order was	\$ 648,436,000
The Contract Price will be changed by this Change Order in the amount of	0
The new Contract Price including this Change Order will be	\$ 648,436,000

**Adjustment to dates in Project Schedule**

The following dates are modified (*list all dates modified; insert N/A if no dates modified*):

---

The Target Bonus Date will be unchanged.

The Guaranteed Substantial Completion Date will be unchanged

Adjustment to other Changed Criteria: *N/A*

Adjustment to Payment Schedule: None

Adjustment to Minimum Acceptance Criteria: None

Adjustment to Performance Guarantees: None

Adjustment to Design Basis: None

Other adjustments to liability or obligation of Contractor or Owner under the Agreement: None

This Change Order **shall not** constitute a full and final settlement and accord and satisfaction of all effects of the change as described in this Change Order upon the Changed Criteria and therefore shall not be deemed to compensate Contractor fully for such change.

Upon execution of this Change Order by Owner and Contractor, the above-referenced change shall become a valid and binding part of the original Agreement without exception or qualification, unless noted in this Change Order. Except as modified by this and any previously issued Change Orders, all other terms and conditions of the Agreement shall remain in full force and effect. This Change Order is executed by each of the Parties' duly authorized representatives.

/s/ Charif Souki

\* Charif Souki  
Chairman

/s/ C. Asok Kumar

Contractor

C. Asok Kumar

Name

Project Director

Title

March 30, 2005

Date of Signing

Date of Signing

/s/ Keith Meyer

\* Keith Meyer  
President

March 29, 2005

Date of Signing

/s/ Ed Lehotsky

\* Ed Lehotsky  
Owner Representative

March 29, 2005

Date of Signing

\* Required Owner signature

**SCHEDULE D-1**  
**CHANGE ORDER FORM**

**PROJECT NAME:** Sabine Pass LNG Receiving,  
Storage and Regasification Terminal

**CHANGE ORDER NUMBER:** SP/BE-006

**DATE OF CHANGE ORDER:** April 18, 2005

**OWNER:** Sabine Pass LNG, L.P.

**CONTRACTOR:** Bechtel Corporation

**DATE OF AGREEMENT:** December 18, 2004

---

**The Agreement between the Parties listed above is changed as follows:**

Attachment EE of the Agreement is replaced by the attached Attachment EE, Rev 1. All references in the Agreement to Attachment EE shall be understood to refer to Attachment EE, Rev 1.

**Adjustment to Contract Price**

The original Contract Price was	\$ 646,936,000
Net change by previously authorized Change Orders (#SP/BE-002)	\$ 1,500,000
The Contract Price prior to this Change Order was	\$ 648,436,000
The Contract Price will be unchanged by this Change Order	\$ 0
The new Contract Price including this Change Order will be	\$ 648,436,000

**Adjustment to dates in Project Schedule**

The following dates are modified (*list all dates modified; insert N/A if no dates modified*):

The Target Bonus Date will be unchanged.

The Target Bonus Date as of the date of this Change Order therefore is 1,095 Days following NTP

The Guaranteed Substantial Completion Date will be unchanged.

The Guaranteed Substantial Completion Date as of the date of this Change Order therefore is 1,247 Days following NTP

Adjustment to other Changed Criteria: None

Adjustment to Minimum Acceptance Criteria: None

Adjustment to Performance Guarantees: None

Adjustment to Design Basis: None

Other adjustments to liability or obligation of Contractor or Owner under the Agreement:

1. In addition to the due Monthly Payments, Milestone Payments, and Reimbursable Costs described in the Agreement, Contractor shall invoice the applicable Tank Subcontract Materials Adjustment in the Month immediately following the Month in which the materials are received (ex-mill or ex-works) by the Tank Subcontractor, and Owner shall make payment to Contractor in accordance with Section 7.2E of the Agreement.
2. To provide clarification, Owner and Contractor have jointly performed the sample calculations shown in Table 1 below using the formulas set forth in Sections 3.2 through 3.9 of Attachment EE Rev 1. The total and component amounts shown in Table 1 are the cost reimbursable material escalation amounts that would be due and payable to Contractor for the period from January 2004 through October 2004, subject to shipment of all affected materials. October 2004 was selected since the LNG Tank Subcontractor had initially updated its proposal to the Contractor as of that date. This escalation amount is not currently included in the Contract Price from Contractor to Owner.

Table I. Sample Calculation through October 2004

		<u>Oct 04</u>	<u>Oct 04</u>
		<u>Index</u>	<u>Escalation</u>
3.2	9% Ni Steel	13440	4,739,797.00
3.3	Rebar & Anchors	520	245,313.40
3.4	Tank Stainless Steel	3480	205,097.28
3.5	Aluminum	137	310,857.79
3.6	Carbon Steel	744	8,368,940.93
3.7	Structural Steel	574	2,582,096.83
3.8	Piping & Valves	3480	1,262,923.94
	Total Escalation to October 2004		\$17,715,027.17

Owner, Contractor, and the Tank Subcontractor have also jointly developed a package, as per Contractor letter to Owner dated March 17, 2005, which provides supporting details and adequately documents the formulas for the Tank Subcontract Materials Adjustments shown in Attachment EE, Rev. 1. Contractor will confirm quantities provided by Tank Subcontractor for rebar by September 2005 and will confirm remaining quantities provided by Tank Subcontractor for structural steel by December 2005. All other quantities have been provided to Owner.



Attachment EE Rev 1 and the Change Order will prevail should any inconsistency occur between Contractor letter of March 17, 2005, and Attachment EE Rev 1 and the Change Order.

Upon execution of this Change Order by Owner and Contractor, the above-referenced change shall become a valid and binding part of the original Agreement without exception or qualification, unless noted in this Change Order. Except as modified by this and any previously issued Change Orders, all other terms and conditions of the Agreement shall remain in full force and effect. This Change Order is executed by each of the Parties' duly authorized representatives.

/s/ Charif Souki  
\_\_\_\_\_  
\* Charif Souki  
Chairman

\_\_\_\_\_  
Date of Signing

/s/ Keith Meyer  
\_\_\_\_\_  
\* Keith Meyer  
President

April 21, 2005  
\_\_\_\_\_  
Date of Signing

/s/ Ed Lehotsky  
\_\_\_\_\_  
\* Ed Lehotsky  
Owner Representative

April 20, 2005  
\_\_\_\_\_  
Date of Signing

\* Required Owner signature

/s/ C. Asok Kumar  
\_\_\_\_\_  
Contractor

C. Asok Kumar  
\_\_\_\_\_  
Name

Project Director  
\_\_\_\_\_  
Title

April 26, 2005  
\_\_\_\_\_  
Date of Signing

**SCHEDULE D-1**  
**CHANGE ORDER FORM**

**PROJECT NAME:** Sabine Pass LNG Receiving,  
Storage and Regasification Terminal

**CHANGE ORDER NUMBER:** SP/BE-007

**DATE OF CHANGE ORDER:** June 2, 2005

**OWNER:** Sabine Pass LNG, L.P.

**CONTRACTOR:** Bechtel Corporation

**DATE OF AGREEMENT:** December 18, 2004

**The Agreement between the Parties listed above is changed as follows:**

1. Refer to Article 7.1.B, "Insurance Allowance," and incorporate the following "Actual Insurance Cost:"

<u>Builders Risk</u>	
- Base Policy	\$ 5,330,000
- Base DSU Policy	\$ 2,474,594
- Wind/Flood DSU Deductible	\$ 247,593
- Excess Wind/Flood	\$ 1,900,000
- Excess Wind/Flood Taxes	\$ 69,975
	<u>\$ 10,022,162</u>
<u>Marine Cargo</u>	
- Hard Cost Premium	\$ 150,000
- DSU Premium	\$ 735,708
	<u>\$ 885,708</u>
<u>General Liability (Owner Share)</u>	
- Named Insured	\$ 580,740
- Pollution Legal Liability	\$ 177,443
	<u>\$ 758,183</u>
<u>Marine General Liability</u>	\$ 425,000
Total "Actual Insurance Cost"	<u>\$ 12,091,053</u>

2. Refer to Article 7.1.B, "Insurance Allowance," and the above "Actual Insurance Cost," and increase the Contract Price by the difference as follows:

"Actual Insurance Cost"	\$ 12,091,053
"Insurance Allowance"	\$ 5,600,000
	<u>\$ 6,491,053</u>

3. Refer to Article 7.1.B, "Insurance Allowance," and Article 9.1.A, "Provision of Insurance," and incorporate Attachment O, Revision 1, which is made a part of this Change Order by attachment. All references in the Agreement to Attachment O shall be understood to refer to Attachment O, Revision 1.
4. Refer to Article 7.1.B, "Insurance Allowance," and in the fourth line delete the words, "charterer legal liability" and replace with "marine general liability."

---

**Adjustment to Contract Price**

The original Contract Price was	\$ 646,936,000
Net change by previously authorized Change Orders (#SP/BE-002)	\$ 1,500,000
The Contract Price prior to this Change Order was	\$ 648,436,000
The Contract Price will be changed by this Change Order in the amount of	\$ 6,491,053
The new Contract Price including this Change Order will be	\$ 654,927,053

**Adjustment to dates in Project Schedule**

The following dates are modified (*list all dates modified; insert N/A if no dates modified*):

The Target Bonus Date will be unchanged.

The Target Bonus Date as of the date of this Change Order therefore is 1,095 Days following NTP.

The Guaranteed Substantial Completion Date will be unchanged.

The Guaranteed Substantial Completion Date as of the date of this Change Order therefore is 1,247 Days following NTP.

Adjustment to other Changed Criteria: None

Adjustment to Payment Schedule: Refer to Schedule C-1 "Milestone Payment Schedule" and add the following:

- Milestone Number 3.10 Actual Insurance Cost—Payment 1: \$ 2,588,756
- Milestone Number 13.05 Actual Insurance Cost—Payment 2: \$ 3,902,297

Adjustment to Minimum Acceptance Criteria: None

Adjustment to Performance Guarantees: None

Adjustment to Design Basis: None

Other adjustments to liability or obligation of Contractor or Owner under the Agreement: None

This Change Order **shall** constitute a full and final settlement and accord and satisfaction of all effects of the change as described in this Change Order upon the Changed Criteria and shall be deemed to compensate Contractor fully for such change; provided, however, that the Parties acknowledge and agree that the "Actual Insurance Cost" herein is based on current estimates and is subject to further adjustment based on final costs for marine cargo insurance, marine general liability insurance, taxes for excess wind and flood coverage, and Marine Terminal Liability Operations insurance.

Upon execution of this Change Order by Owner and Contractor, the above-referenced change shall become a valid and binding part of the original Agreement without exception or qualification, unless noted in this Change Order. Except as modified by this and any previously issued Change Orders, all other terms and conditions of the Agreement shall remain in full force and effect. This Change Order is executed by each of the Parties' duly authorized representatives.

/s/ Charif Souki  
Owner

Charif Souki  
Name

CEO  
Title

June 3, 2005  
Date of Signing

/s/ C. Asok Kumar  
Contractor

C. Asok Kumar  
Name

Project Director  
Title

June 6, 2005  
Date of Signing

/s/ Keith Meyer  
Owner

Keith Meyer  
Name

Title

June 3, 2005  
Date of Signing

/s/ Ed Lehotsky  
Owner

Ed Lehotsky  
Name

Owner Representative  
Title

June 2, 2005  
Date of Signing

/s/ Stanley C. Horton  
Owner

Stanley C. Horton  
Name

President and COO  
Title

June 3, 2005  
Date of Signing

**SCHEDULE D-1**  
**CHANGE ORDER FORM**

**PROJECT NAME:** Sabine Pass LNG Receiving,  
Storage and Regasification Terminal

**CHANGE ORDER NUMBER:** SP/BE-008

**DATE OF CHANGE ORDER:** 06/13/2005

**OWNER:** Sabine Pass LNG, L.P.

**CONTRACTOR:** Bechtel Corporation

**DATE OF AGREEMENT:** December 18, 2004

---

**The Agreement between the Parties listed above is changed as follows:**

Approval of Change Orders via Schedule D-1 and D-2 of the EPC Agreement will require the signatures of Messrs. Charif Souki (except as further provided in the next sentence), Stan Horton, Keith Meyer, in addition to the designated Owner Representative, Ed Lehotsky. Mr. Horton is authorized to sign Change Orders on behalf of Mr. Souki during Mr. Souki's absence. This requirement will not apply to any other correspondence under the EPC Agreement.

A revised copy of Schedules D-1 (Rev 2) and D-2 (Rev 2) is attached reflecting the above change.

---

**Adjustment to Contract Price**

The original Contract Price was	\$ 646,936,000
Net change by previously authorized Change Orders (#SP/BE-002 & 007)	\$ 7,991,053
The Contract Price prior to this Change Order was	\$ 654,927,053
The Contract Price will be unchanged by this Change Order in the amount of	\$ 0
The new Contract Price including this Change Order will be	\$ 654,927,053

**Adjustment to dates in Project Schedule**

The following dates are modified (*list all dates modified; insert N/A if no dates modified*):

The Target Bonus Date will be unchanged.

The Target Bonus Date as of the date of this Change Order therefore is 1,095 Days following NTP.

The Guaranteed Substantial Completion Date will be unchanged.

The Guaranteed Substantial Completion Date as of the date of this Change Order therefore is 1,247 Days following NTP.

Adjustment to other Changed Criteria: None

Adjustment to Payment Schedule: None

Adjustment to Minimum Acceptance Criteria: None

Adjustment to Performance Guarantees: None

Adjustment to Design Basis: None

Other adjustments to liability or obligation of Contractor or Owner under the Agreement: N/A



**SCHEDULE D-1  
CHANGE ORDER FORM**

**PROJECT NAME:** Sabine Pass LNG Receiving,  
Storage and Regasification Terminal

**CHANGE ORDER NUMBER:** SP/BE-009

**DATE OF CHANGE ORDER:** June 20, 2005

**OWNER:** Sabine Pass LNG, L.P.

**CONTRACTOR:** Bechtel Corporation

**DATE OF AGREEMENT:** December 18, 2004

**Attachment EE Adjustments (Stainless Steel, Marine Loading Arms & BOG Compressor)**

The Agreement between the Parties listed above is changed as follows:

Reference: Contract Attachment EE (Stainless Steel Adjustment, Tank Subcontract Materials Adjustment, Marine Loading Arm Adjustment and BOG Compressor Adjustment) Bechtel Letter SDN 25027-001-T05-GAM-00039 dated March 17, 2005 Bechtel Letter SDN 25027-001-T05-GAM-00062 dated April 26, 2005

Per Executed Change Order No. SP/BE-006 (signed April 26, 2005), Attachment EE Rev. 1, the Contract Price is adjusted as follows:

Stainless Steel Adjustment: The Stainless Steel adjustment, which is used to account for the changes in commodity pricing of 304L stainless steel pipe, fittings and flanges as described in Section 7.ID of the Agreement, shall be determined in accordance with Section 1 of Attachment EE, Rev. 1. All calculations shall be rounded to four (4) decimal places. See attached document titled "Contract Att. EE Rev. 1 Adjustments," dated June 16, 2005, 1 page, supporting total upward adjustment amount of \$10,305,924.

Marine Loading Arm Adjustment and BOG Compressor Adjustment: The Marine Loading Arm Adjustment and BOG Compressor Adjustment, which are used to take into account currency fluctuations as described in Sections 7.1 .F and 7.1 .G respectively, shall be determined in accordance with Section 2 of Attachment EE, Rev. 1. All calculations shall be rounded to four (4) decimal places. All currency exchange rates shall be determined using *FxConverter* on website <http://www.oanda.com/convert/classic>. See attached document titled "Contract Att. EE Rev. 1 Adjustments," dated June 16, 2005, 1 page, supporting total upward adjustment amount of \$102,010

The original Contract Price was	\$ 646,936,000
Net change by previously authorized Change Orders (#SP/BE-002 & 007)	\$ 7,991,053
The Contract Price prior to this Change Order was	\$ 654,927,053
The Contract Price will be increased by this Change Order in the amount of	\$ 10,407,934
The new Contract Price including this Change Order will be	\$ 665,334,987

Adjustment to dates in Project Schedule

The following dates are modified (*list all dates modified; insert N/A if no dates modified*):

The Target Bonus Date will be unchanged.

The Target Bonus Date as of the date of this Change Order therefore is 1,095 Days following NTP.

The Guaranteed Substantial Completion Date will be unchanged.

---

**SCHEDULE D-1**  
**CHANGE ORDER FORM**

**PROJECT NAME:** Sabine Pass LNG Receiving,  
Storage and Regasification Terminal

**CHANGE ORDER NUMBER:** SP/BE-009

**DATE OF CHANGE ORDER:** June 20, 2005

**OWNER:** Sabine Pass LNG, L.P.

**CONTRACTOR:** Bechtel Corporation

**DATE OF AGREEMENT:** December 18, 2004

**Attachment EE Adjustments (Stainless Steel, Marine Loading Arms & BOG Compressor)**

---

The Guaranteed Substantial Completion Date as of the date of this Change Order therefore is 1,247 Days following NTP.

Adjustment to other Changed Criteria: Not Applicable

Adjustment to Payment Schedule: See attached "Payment Milestones" 1 page, dated June 16, 2005

Adjustment to Minimum Acceptance Criteria: No Change

Adjustment to Performance Guarantees: No Change

Adjustment to Design Basis: No Change

Other adjustments to liability or obligation of Contractor or Owner under the Agreement: No Change

This Change Order **shall** constitute a full and final settlement and accord and satisfaction of all effects of the change as described in this Change Order upon the Changed Criteria and shall be deemed to compensate Contractor fully for such change.

Upon execution of this Change Order by Owner and Contractor, the above-referenced change shall become a valid and binding part of the original Agreement without exception or qualification, unless noted in this Change Order. Except as modified by this and any previously issued Change Orders, all other terms and conditions of the Agreement shall remain in full force and effect. This Change Order is executed by each of the Parties' duly authorized representatives.

/s/ Charif Souki

\_\_\_\_\_  
\* Charif Souki  
Chairman

/s/ C. Asok Kumar

\_\_\_\_\_  
Contractor

C. Asok Kumar

\_\_\_\_\_  
Name

Project Manager

\_\_\_\_\_  
Title

6/20/05

\_\_\_\_\_  
Date of Signing

\_\_\_\_\_  
Date of Signing



---

**SCHEDULE D-1  
CHANGE ORDER FORM**

**PROJECT NAME:** Sabine Pass LNG Receiving,  
Storage and Regasification Terminal

**CHANGE ORDER NUMBER:** SP/BE-009

**DATE OF CHANGE ORDER:** June 20, 2005

**OWNER:** Sabine Pass LNG, L.P.

**CONTRACTOR:** Bechtel Corporation

**DATE OF AGREEMENT:** December 18, 2004

**Attachment EE Adjustments (Stainless Steel, Marine Loading Arms & BOG Compressor)**

---

/s/ Stan Horton

\_\_\_\_\_  
\* Stan Horton  
President & COO Cheniere Energy

\_\_\_\_\_  
Date of Signing

/s/ Keith Meyer

\_\_\_\_\_  
\* Keith Meyer  
President Cheniere LNG

July 19, 2005

\_\_\_\_\_  
Date of Signing

/s/ Ed Lehotsky

\_\_\_\_\_  
\* Ed Lehotsky  
Owner Representative

July 19, 2005

\_\_\_\_\_  
Date of Signing

\* Required Owner signature

**SCHEDULE D-1**  
**CHANGE ORDER FORM**

**PROJECT NAME:** Sabine Pass LNG Receiving,  
Storage and Regasification Terminal

**CHANGE ORDER NUMBER:** SP/BE-010

**DATE OF CHANGE ORDER:** 6/17/2005

**OWNER:** Sabine Pass LNG, L.P.

**CONTRACTOR:** Bechtel Corporation

**DATE OF AGREEMENT:** December 18, 2004

---

**The Agreement between the Parties listed above is changed as follows:**

FERC Cryogenic Review

In accordance with Attachment A, Section 13.4, "Additional FERC Requirements," Contractor was directed by Owner to incorporate FERC Cryogenic review comments imposed by FERC after June 1, 2004. Approval to incorporate comments is based on the following referenced documents previously provided to Owner:

- Owner Meeting Action Items, No. 14, Issue No. 3, dated February 2, 2005
- Bechtel Conference Notes 25027-001-G15-GAM-00008 dated February 7, 2005
- Bechtel Conference Notes 25027-001-G-15-GAM-00009 dated February 15, 2005, Item No. 4
- Bechtel Letter SDN 25027-001-T05-GAM-00031 dated March 4, 2005

Changes to Scope of Work are included in the following documents:

- Trend T-008 - Cryogenic Comments, dated April 15, 2005
- Owner's response to FERC, Docket No. CPO4-47-000 "Cryogenic Information Request," 34 pages
- Lump Sum Change Order "FERC Cryogenic Comments - Detail Estimate (BECR-002) / Revised per Owner Comments" Revision 3, dated June 9, 2005, 3 pages.
- "FERC Cryogenic Comments - Payment Milestones (BECR-002)" dated June 9, 2005

**Detailed Reasons for Proposed Change(s)** (*provide detailed reasons for the proposed change, and attach all supporting documentation required under the Agreement*)

Per Attachment A, Article 13.4 of the Agreement, Contractor shall commence work on any additional requirements imposed by FERC after June 1, 2004, and which are not included in the Scope of Work or the Agreement. Details of the proposed change and supporting documents are listed above.

Note: This Change Order does not address or include Changed Criteria for other additional FERC requirements under Attachment A, Article 13.4, since sufficient information is only available to address the FERC Cryogenic comments. Other outstanding potential issues will be addressed individually, as requested by Owner, and will be the subject of a separate Change Order as may be appropriate. Reference Owner letter SP-13E-C-038 dated March 31, 2005 and Contractor letter SDN-25027-001-T05-GAM-00055 dated April 12, 2005.

---

**Adjustment to Contract Price**

The original Contract Price was	\$ 646,936,000
Net change by previously authorized Change Orders OSP/BE-002, 007& 009	\$ 18,398,987
The Contract Price prior to this Change Order was	\$ 665,334,987
The Contract Price will be increased by this Change Order in the amount of	\$ 4,378,557
The new Contract Price including this Change Order will be	\$ 669,713,544

**Adjustment to dates in Project Schedule**

---

The following dates are modified (*list all dates modified; insert N/A if no dates modified*):

The Target Bonus Date will be unchanged.

The Target Bonus Date as of the date of this Change Order therefore is 1,095 Days following NTP.

The Guaranteed Substantial Completion Date will be unchanged.

The Guaranteed Substantial Completion Date as of the date of this Change Order therefore is 1,247 Days following NTP.

Adjustment to other Changed Criteria: None

Adjustment to Payment Schedule: See attached "FERC Cryogenic Comments—Payment Milestones," 1 page, dated June 9, 2005.

Adjustment to Minimum Acceptance Criteria: None

Adjustment to Performance Guarantees: None

Adjustment to Design Basis: None

Other adjustments to liability or obligation of Contractor or Owner under the Agreement: N/A

This Change Order **shall** constitute a full and final settlement and accord and satisfaction of all effects of the change as described in this Change Order upon the Changed Criteria and shall be deemed to compensate Contractor fully for such change.

Upon execution of this Change Order by Owner and Contractor, the above-referenced change shall become a valid and binding part of the original Agreement without exception or qualification, unless noted in this Change Order. Except as modified by this and any previously issued Change Orders, all other terms and conditions of the Agreement shall remain in full force and effect. This Change Order is executed by each of the Parties' duly authorized representatives.

/s/ Charif Souki  
\* Charif Souki  
Chairman

\_\_\_\_\_  
Date of Signing

/s/ Stan Horton  
\*Stan Horton  
President & COO Cheniere Energy

July 19, 2005  
Date of Signing

/s/ C. Asok Kumar  
Contractor

C. Asok Kumar  
Name

Project Director  
Title

July 29, 2005  
Date of Signing

---

/s/ Keith Meyer

\* Keith Meyer  
President Cheniere LNG

July 19, 2005

Date of Signing

/s/ Ed Lehotsky

\* Ed Lehotsky  
Owner Representative

July 19, 2005

Date of Signing

\*Required Owner Signature

**SCHEDULE D-1**  
**CHANGE ORDER FORM**

**PROJECT NAME:** Sabine Pass LNG Receiving,  
Storage and Regasification Terminal

**CHANGE ORDER NUMBER:** SP/BE-011

**DATE OF CHANGE ORDER:** June 24, 2005

**OWNER:** Sabine Pass LNG, L.P.

**CONTRACTOR:** Bechtel Corporation

**DATE OF AGREEMENT:** December 18, 2004

---

**The Agreement between the Parties listed above is changed as follows:**

Owner and Contractor agree that the Agreement shall be amended as follows:

1. The following new Section 11.10 shall be added to the Agreement:

“11.10 **Early Completion Bonus.** Contractor shall earn an early completion bonus in the amount of Sixty-Seven Thousand U.S. Dollars (U.S.\$67,000) per Day for each complete Day that Contractor achieves Early Completion prior to April 1, 2008 (the “Early Completion Date”), up to a maximum of Six Million U.S. Dollars (U.S.\$6,000,000) (the “Early Completion Bonus”). Neither the Early Completion Date nor the Early Completion Bonus shall be subject to adjustment or extension under any circumstance, whether by Change Order or other provision of the Agreement (including an event of Force Majeure or Owner caused delay). If Contractor earns the Early Completion Bonus or any portion thereof, Contractor shall invoice Owner for the applicable amount of such Early Completion Bonus, and Owner shall pay Contractor the applicable amount of such Early Completion Bonus within the time required under this Agreement for making payments of amounts invoiced by Contractor. The failure of Contractor to earn the Early Completion Bonus shall not create a separate liability for either Owner or Contractor under this Agreement.”

2. The following definitions shall be added under Section 1.1 to the Agreement:

“**Early Completion**” shall mean that all of the following have occurred with respect to the Facility: (i) Cool Down has been completed for System 1 and System 2; (ii) Contractor has completed all procurement, fabrication, assembly, erection, installation and precommissioning checks of all of the vaporizers for the Facility to ensure that all such vaporizers and each component thereof was sufficiently fabricated, assembled, erected and installed so as to be capable of being operated safely within the requirements contained in this Agreement, and thirteen vaporizers have been operated to their rated capacity; (iii) Contractor has completed all procurement, fabrication, assembly, erection, installation and pre-commissioning checks and tests of System 1 and System 2 to ensure that these Systems and each component thereof was sufficiently fabricated, assembled, erected and installed so as to be capable of being operated safely within the requirements contained in this Agreement; and (iv) System 1 and System 2, collectively, are capable of a Sendout Rate of 2,000 MMSCFD or above at a temperature of no less than 40°F and at a pressure of no less than 1,440 PSIG, as measured at the exit for the main Facility transfer meter. The status of being “capable” shall be determined by such tests or operational records as may be mutually agreed by the Parties prior to Contractor’s achievement of Early Completion.

“**Early Completion Bonus**” has the meaning set forth in Section 11.10.

“**Early Completion Date**” has the meaning set forth in Section 11.10.”

There are no other modifications to the Agreement relating to this Change Order.

**Adjustment to Contract Price**

The original Contract Price was	\$ 646,936,000
Net change by previously authorized Change Orders (#SP/BE-002, 007, 009 & 010)	\$ 22,777,544
The Contract Price prior to this Change Order was	\$ 669,713,544
The Contract Price will be increased by a separate Change Order if Contractor earns the Early Completion Bonus or any portion thereof as per the provisions of the Change Order	

**Adjustment to dates in Project Schedule**

The following dates are modified (*list all dates modified; insert N/A if no dates modified*):

The Target Bonus Date will be unchanged.

The Target Bonus Date as of the date of this Change Order therefore is 1,095 Days following NTP.

The Guaranteed Substantial Completion Date will be unchanged.

The Guaranteed Substantial Completion Date as of the date of this Change Order therefore is 1,247 Days following NTP.

Adjustment to other Changed Criteria: None

Adjustment to Payment Schedule: A separate Change Order will be required to adjust the Payment Schedule if Contractor earns the Early Completion Bonus or any portion thereof

Adjustment to Minimum Acceptance Criteria: None

Adjustment to Performance Guarantees: None

Adjustment to Design Basis: None

Other adjustments to liability or obligation of Contractor or Owner under the Agreement: N/A

This Change Order shall not constitute a full and final settlement and accord and satisfaction of all effects of the change as described in this Change Order upon the Changed Criteria and shall not be deemed to compensate Contractor fully for such change.

Upon execution of this Change Order by Owner and Contractor, the above-referenced change shall become a valid and binding part of the original Agreement without exception or qualification, unless noted in this Change Order. Except as modified by this and any previously issued Change Orders, all other terms and conditions of the Agreement shall remain in full force and effect. This Change Order is executed by each of the Parties' duly authorized representatives.

/s/ Charif Souki  
\* Charif Souki  
Chairman

/s/ C. Asok Kumar  
Contractor

C. Asok Kumar  
Name

Project Director  
Title

July 29, 2005

Date of Signing

Date of Signing

---

/s/ Stan Horton

\*Stan Horton  
President & COO Cheniere Energy

July 19, 2005

Date of Signing

/s/ Keith Meyer

\*Keith Meyer  
President Cheniere LNG

July 19, 2005

Date of Signing

/s/ Ed Lehotsky

\*Ed Lehotsky  
Owner Representative

July 19, 2005

Date of Signing

\*Required Owner signature - Mr. Horton may sign on behalf of Mr. Souki during Mr. Souki's absence.

SCHEDULE D-2

PROJECT NAME: Sabine Pass LNG Receiving  
Storage and Regasification Terminal

CHANGE ORDER NUMBER: SP/BE-012

DATE OF CHANGE ORDER: 7/12/2005

OWNER: Sabine Pass LNG, L.P.

CONTRACTOR: BECHTEL CORPORATION

DATE OF AGREEMENT: December 18, 2004

You are hereby directed to make the following additions or modifications to, or deductions from, the Work:

Implement the following P&ID and Cause & Effect Scope Option Items (refer to the attached Trend Matrix for further information) as discussed in the review meetings and subsequent correspondence:

Item	Description	Prelim Cost Estimates
3.06	Add local and remote actuators for (4) 16" and (2) 24" valves	\$ 240,000
4.16	Delete 10" SS insulated tanker BOG vent line to storage tanks	\$ (200,000)
7.04	Add actuators to (3) 30" valves	(150,000)
9.03	Nitrogen snuffing system piping revision at (3) Tanks	\$ 80,000
10.04	Add Tank mixing jumper line - (1) location	\$ 100,000
13.01	Add actuators and Jump over line for Recondensor	\$ 50,000
18.05	Add 42" future connection to the gas metering	\$ 20,000
19.06	Delete LP vent stack, associated piping & valves from Tank area	\$ (120,000)
20.05	Add switch in Control Room	\$ 0
20.06	Add Jumper to Blower section & move valves	\$ 60,000
10.00	Cause & Effect scope - Add thermal relief valves	\$ 120,000
	<b>Total Order of Magnitude Cost</b>	<b>\$ 500,000</b>

Contractor shall proceed with the above design changes and prepare detailed Lump Sum cost estimates. Upon final review and approval by Owner of the detailed estimate, Contractor shall prepare the required documentation, including a completed Schedule D-3 in accordance with Article 6.1A of the Agreement.

Compensation for the changes specified in this Change Order is on a time and materials basis as provided in Section 6.1C and 6.2D of the Agreement.

Contractor shall commence with the performance of the change(s) described above on **July 18, 2005**

This Change Order is signed by Owner's duly authorized representatives.

/s/ Charif Souki

\*Charif Souki  
Chairman

Date of Signing

/s/ Stan Horton

\*Stan Horton  
President and COO Cheniere Energy

July 19, 2005

Date of Signing



---

/s/ Keith Meyer

\*Keith Meyer  
President Cheniere LNG

/s/ Ed Lehotsky

\*Ed Lehotsky  
Owner Representative

July 19, 2005

Date of Signing

July 19, 2005

Date of Signing

\*Required Owner signature-Mr. Horton may sign on behalf of Mr. Souki during Mr. Souki's absence.

---

**SCHEDULE D-2**  
**UNILATERAL CHANGE ORDER FORM**

**PROJECT NAME:** Sabine Pass LNG Receiving,  
Storage and Regasification Terminal

**CHANGE ORDER NUMBER:** SP/BE-013

**DATE OF CHANGE ORDER:** 7/18/2005

**OWNER:** Sabine Pass LNG, L.P.

**CONTRACTOR:** Bechtel Corporation

**DATE OF AGREEMENT:** December 18, 2004

---

**You are hereby directed to make the following additions or modifications to the Work**

**Implement the following SCV Options to be included in the SCV design as referenced in the attached Bechtel letter GAM-00117 dated June 30, 2005.**

- 1) Two (2) each stainless steel SS 3" diameter blind block /check valves for taking water circulation pump out of service, blinded tee and solenoid valve for future connection of utility water. Excludes future utility water piping, wiring from MCC starter to solenoid valve and extra terminal on motor starter.
- 3) Replace PLC with DCS Control. Your project team should work with James Pfeffer on the design of the DCS control. Refer to Owner's letter SP-BE-C-084 for further guidance, a copy of which is attached to this Change Order.
- 4) Provide vaporizer modification on all 16 units to accommodate a hot water sparger in the water bath for waste heat recovery from gas turbine exhaust, as well all other items captured in this item.
- 8) Sixteen (16) each 42' exhaust stacks in SS rather than painted CS

**Contractor shall proceed with the above design changes and prepare the required documentation, including a completed Schedule D-3 in accordance with Articles 6.1A and 6.1C of the Agreement.**

---

Compensation for the changes specified in this Change Order is on a time and materials basis as provided in Section 6.1C and 6.2D of the Agreement.

Contractor shall commence with the performance of the change(s) described above **on July 18, 2005**

This Change Order is signed by Owner's duly authorized representatives.

/s/ Charif Souki

Charif Souki  
Chairman

/s/ Stan Horton

\*Stan Horton  
President and COO Cheniere Energy

---

Date of Signing

July 19, 2005

---

Date of Signing

---

/s/ Keith Meyer

\* Keith Meyer  
President Cheniere LNG

---

/s/ Ed Lehotsky

\* Ed Lehotsky  
Owner Representative

---

July 19, 2005

Date of Signing

---

July 19, 2005

Date of Signing

\* Required Owner signature - Mr. Horton may sign on behalf of Mr. Souki during Mr. Souki's absence.

**SCHEDULE D-1**  
**CHANGE ORDER FORM**

**PROJECT NAME:** Sabine Pass LNG Receiving,  
Storage and Regasification Terminal

**CHANGE ORDER NUMBER:** SP/BE-014

**DATE OF CHANGE ORDER:** September 19, 2005

**OWNER:** Sabine Pass LNG, L.P.

**CONTRACTOR:** Bechtel Corporation

**DATE OF AGREEMENT:** December 18, 2004

**Air Permit Revision by T-Thermal - Best Available Control Technology (BACT)**

**The Agreement between the Parties listed above is changed as follows:**

In accordance with the EPC Agreement, Attachment A, Schedule A-1, Section 13.2, Owner directs Contractor to modify submerged combustion vaporizers as necessary to meet the requirements of the air permit. This includes the following:

- 1.) Basic BACT emission compliance (40 ppm NOx to 30 ppm NOx): Consists of blower motor HP increase from 600 to 800 HP, increased flue gas sparger size to accommodate the increased flue gas flow, increased combustion air piping to accommodate the increased air flow and more sophisticated fuel/air ratio controls.
- 2.) Compliance with reduced CO (80 ppm to 40 ppm) per LDEQ permit is not required; however, Owner agrees to fund initial design, drafting and project management already expended by T-Thermal in its efforts to achieve CO emissions (80 ppm to 40ppm).
- 3.) Increased stack height: From 38 feet to 42 feet above bottom of SCV as directed by Owner

On June 27, 2005, a meeting was held among Owner, Bechtel and the SCV supplier (T-Thermal), to review scope of work and pricing provided by T-Thermal to Contractor in BECR-004, dated June 3, 2005. This Change Order incorporates Owner's (J. Kaucher and D. Granger) selection of work scope and agreement on direct pricing from T-Thermal to Contractor, Owner's direction to delete the requirement of 40ppm CO at 3% O2 necessary to comply with the current LDEQ permit (Note: Owner advised Bechtel a permit revision request would be submitted and obtained from LDEQ for this), and incorporation of pricing methodology agreed between Bechtel and Owner on August 3, 2005.

See attached files for details:

- "T-0020a Trend Form Rev BACT and Emissions Rev 2a.xls" dated August 2, 2005, 1 page
- "T-0020a Payment Milestones Rev 2.xls" dated August 2, 2005, 1 page

**Adjustment to Contract Price**

The original Contract Price was	\$ 646,936,000
Net change by previously authorized Change Orders (#SP/BE-002 thru 013)	\$ 22,777,544
The Contract Price prior to this Change Order was	\$ 669,713,544
The Contract Price will be increased by this Change Order in the amount of	\$ 880,000
The new Contract Price including this Change Order will be	\$ 670,593,544

---

**SCHEDULE D-1**  
**CHANGE ORDER FORM**

**PROJECT NAME:** Sabine Pass LNG Receiving,  
Storage and Regasification Terminal

**CHANGE ORDER NUMBER:** SP/BE-014

**DATE OF CHANGE ORDER:** September 19, 2005

**OWNER:** Sabine Pass LNG, L.P.

**CONTRACTOR:** Bechtel Corporation

**DATE OF AGREEMENT:** December 18, 2004

**Air Permit Revision by T-Thermal - Best Available Control Technology (BACT)**

---

**Adjustment to dates in Project Schedule**

The following dates are modified:

The Target Bonus Date will be unchanged.

The Target Bonus Date as of the date of this Change Order therefore is 1,095 Days following NTP.

The Guaranteed Substantial Completion Date will be unchanged.

The Guaranteed Substantial Completion Date as of the date of this Change Order therefore is 1,247 Days following NTP.

Adjustment to other Changed Criteria: Not Applicable

Adjustment to Payment Schedule: See attached "Payment Milestones" 1 page, dated August 2, 2005.

Adjustment to Minimum Acceptance Criteria: No Change

Adjustment to Performance Guarantees: No Change

Adjustment to Design Basis: Yes, as modified in this Change Order

Other adjustments to liability or obligation of Contractor or Owner under the Agreement: No Change

This Change Order **shall** constitute a full and final settlement and accord and satisfaction of all effects of the change as described in this Change Order upon the Changed Criteria and shall be deemed to compensate Contractor fully for such change.

Upon execution of this Change Order by Owner and Contractor, the above-referenced change shall become a valid and binding part of the original Agreement without exception or qualification, unless noted in this Change Order. Except as modified by this and any previously issued Change Orders, all other terms and conditions of the Agreement shall remain in full force and effect. This Change Order is executed by each of the Parties' duly authorized representatives.

---

**SCHEDULE D-1**  
**CHANGE ORDER FORM**

**PROJECT NAME:** Sabine Pass LNG Receiving,  
Storage and Regasification Terminal

**CHANGE ORDER NUMBER:** SP/BE-014

**DATE OF CHANGE ORDER:** September 19, 2005

**OWNER:** Sabine Pass LNG, L.P.

**CONTRACTOR:** Bechtel Corporation

**DATE OF AGREEMENT:** December 18, 2004

**Air Permit Revision by T-Thermal - Best Available Control Technology (BACT)**

---

/s/ Stan Horton  
\* Charif Souki  
Chairman

/s/ C. Asok Kumar  
Contractor

C. Asok Kumar  
Name

Project Director  
Title

September 19, 2005  
Date of Signing

Date of Signing

/s/ Stan Horton  
\* Stan Horton  
President & COO Cheniere Energy

October 17, 2005  
Date of Signing

/s/ Keith Meyer  
\* Keith Meyer  
President Cheniere LNG

October 17, 2005  
Date of Signing

/s/ Ed Lehotsky  
\* Ed Lehotsky  
Owner Representative

October 11, 2005  
Date of Signing

\* Required Owner signature - Mr. Horton may sign on behalf of Mr. Souki during Mr. Souki's absence.

**SCHEDULE D-1**  
**CHANGE ORDER FORM**

**PROJECT NAME:** Sabine Pass LNG Receiving,  
Storage and Regasification Terminal

**CHANGE ORDER NUMBER:** SP/BE-015

**DATE OF CHANGE ORDER:** September 19, 2005

**OWNER:** Sabine Pass LNG, L.P.

**CONTRACTOR:** Bechtel Corporation

**DATE OF AGREEMENT:** December 18, 2004

**Resurvey of Benchmarks for Vertical Datum**

---

**The Agreement between the Parties listed above is changed as follows:**

Reference EPC Agreement, Article 4.8 and Attachment U, Item 2, Owner Supplied Data.

The original topographical survey provided by Owner in the EPC Agreement was incorrect. Based on the above documents, Owner provided revisions to topographical survey data that correctly identifies the Site topography as one foot (1') plus lower than the original survey data benchmark provided in the EPC Agreement. This revision resulted in a Scope of Work change due to additional required quantities of fill materials and related home office and Site activities.

A. The difference between the original and revised Scope of Work results in following additional fill materials:

<input type="checkbox"/> Process area	29,760 cy
<input type="checkbox"/> Administration Building	1,750 cy
<input type="checkbox"/> N2 Package	870 cy
<input type="checkbox"/> Total additional fill	<u>32,380</u> cy

B. Subcontract cost for additional fill materials:

<input type="checkbox"/> Excavate, Haul Install	\$312,467
<input type="checkbox"/> Stabilize Fill at 8% Lime	<u>\$387,259</u>
<input type="checkbox"/> Total Cost	\$699,726

C. Basis for Cut and Fiji Quantities in the Model:

- Process areas elevated to +12 feet
- Concrete foundations are erected on top of fill material
- Avoids working on elevated structures
- Additional materials are assumed to be available from the Marine Berth area

Note: The lower Site results in increased storm water drainage requirements. Ditch and culvert sizes will be increased, however, these increases are considered to be within Contractor's design development activities.

D. Home Office Job Hours:

- Engineering - 250 Hours (C/S/A 150 plus Geo-Tech 100)
- Project Support - 75 Hours

E. See attached Bechtel drawing SKC-000-00004, Revision A "Civil Site Development - Rough Grading Excavation and Backfill".

**SCHEDULE D-1**

**CHANGE ORDER FORM**

**PROJECT NAME:** Sabine Pass LNG Receiving, Storage and Regasification Terminal

**CHANGE ORDER NUMBER:** SP/BE-015

**OWNER:** Sabine Pass LNG, L.P.

**DATE OF CHANGE ORDER:** September 19, 2005

**CONTRACTOR:** Bechtel Corporation

**DATE OF AGREEMENT:** December 18, 2004

**Resurvey of Benchmarks for Vertical Datum**

F. See attached file for details:

- "T-0022 Trend Form Rev 1.xls" dated August 2, 2005, 1 page
- "T-0022 Payment Milestones.xls" dated August 4, 2005, 1 page
- "Revised Owner Topographical Vertical Datum Control Elevations", 1 page

**Adjustment to Contract Price**

The original Contract Price was	\$ 646,936,000
Net change by previously authorized Change Orders (#SP/BE-002 thru 014)	\$ 23,657,544
The Contract Price prior to this Change Order was	\$ 670,593,544
The Contract Price will be increased by this Change Order in the amount of	\$ 830,000
The new Contract Price including this Change Order will be	\$ 671,423,544

**Adjustment to dates in Project Schedule**

The following dates are modified (*list all dates modified; insert N/A if no dates modified*):

The Target Bonus Date will be unchanged.

The Target Bonus Date as of the date of this Change Order therefore is 1,095 Days following NTP.

The Guaranteed Substantial Completion Date will be unchanged.

The Guaranteed Substantial Completion Date as of the date of this Change Order therefore is 1,247 Days following NTP.

Adjustment to other Changed Criteria: Not Applicable

Adjustment to Payment Schedule: See attached "Payment Milestones" 1 page, dated August 4, 2005.

Adjustment to Minimum Acceptance Criteria: No Change



**SCHEDULE D-I**

**CHANGE ORDER FORM**

**PROJECT NAME:** Sabine Pass LNG Receiving, Storage and Regasification Terminal

**CHANGE ORDER NUMBER:** SP/BE-015

**DATE OF CHANGE ORDER:** September 19, 2005

**OWNER:** Sabine Pass LNG, L.P.

**CONTRACTOR:** Bechtel Corporation

**DATE OF AGREEMENT:** December 18, 2004

**Resurvey of Benchmarks for Vertical Datum**

Adjustment to Performance Guarantees: No Change

Adjustment to Design Basis: No Change

Other adjustments to liability or obligation of Contractor or Owner under the Agreement: No Change

This Change Order **shall** constitute a full and final settlement and accord and satisfaction of all effects of the change as described in this Change Order upon the Changed Criteria and shall be deemed to compensate Contractor fully for such change.

Upon execution of this Change Order by Owner and Contractor, the above-referenced change shall become a valid and binding part of the original Agreement without exception or qualification, unless noted in this Change Order. Except as modified by this and any previously issued Change Orders, all other terms and conditions of the Agreement shall remain in full force and effect. This Change Order is executed by each of the Parties' duly authorized representatives.

/s/ Stan Horton

\* Charif Souki  
Chairman

Date of Signing

/s/ Stan Horton

\*Stan Horton  
President & COO Cheniere Energy

October 17, 2005

Date of Signing

/s/ C. Asok Kumar

Contractor

C. Asok Kumar

Name

Project Director

Title

September 19, 2005

Date of Signing

---

**SCHEDULE D-1**

**CHANGE ORDER FORM**

**PROJECT NAME:** Sabine Pass LNG Receiving, Storage and Regasification Terminal

**CHANGE ORDER NUMBER:** SP/BE-015

**DATE OF CHANGE ORDER:** September 19, 2005

**OWNER:** Sabine Pass LNG, L.P.

**CONTRACTOR:** Bechtel Corporation

**DATE OF AGREEMENT:** December 18, 2004

**Resurvey of Benchmarks for Vertical Datum**

---

/s/ Keith Meyer

\_\_\_\_\_  
\* Keith Meyer  
President Cheniere LNG

October 17, 2005

\_\_\_\_\_  
Date of Signing

/s/ Ed Lehotsky

\_\_\_\_\_  
\* Ed Lehotsky  
Owner Representative

October 17, 2005

\_\_\_\_\_  
Date of Signing

\* Required Owner signature – Mr. Horton may sign on behalf of Mr. Souki during Mr. Souki's absence.

**SCHEDULE D-2**

**UNILATERAL CHANGE ORDER FORM**

**PROJECT NAME:** Sabine Pass LNG Receiving,  
Storage and Regasification Terminal

**CHANGE ORDER NUMBER:** SP/BE-016

**DATE OF CHANGE ORDER:** 9/28/2005

**OWNER:** Sabine Pass LNG, L.P.

**CONTRACTOR:** Bechtel Corporation

**DATE OF AGREEMENT:** December 18, 2004

You are hereby directed to make the following additions or modifications to, or deductions from, the Work:

Implement the following P&ID HAZOPS Review Items (refer to the attached Trend Matrix for further information) as discussed in the review meetings and subsequent correspondence:

<u>Item</u>	<u>Description</u>	<u>Prelim Cost Estimate</u>
	Process P&ID's	
1.01	Remove manual valves in 30" header piping at storage tanks	(\$ 80,000)
1.07	Provide position indicator on HV24021/2, 2 valves / tank, 6 total	\$ 30,000
1.16	Add 2 ea. local sight flow indicators to each unloading arm	\$ 32,000
2.01	LP / discretionary vent, add 3 -12" vents w/ actuated butterfly valves	\$ 160,000
2.02	Add 1 ea position indicator on PV-24002	\$ 5,000
3.03	Add 1 ea dP w/transmitter and local PI upstream of V-103	\$ 15,000
3.11	For min flow line from in-tank pumps back into storage tanks, use Interlocks to ensure one valve is always open *	\$ 15,000
4.09	Add 10" SS insulated check valve (2 ea) between FV-25002 and V-111	\$ 30,000
4.11	Add flow indication, 2 places, in blanket gas line GN-25612	\$ 40,000
4.12	Add isolation / drain valves at V-111 to allow discretionary vent	\$ 40,000
4.19	Install splash guards at removable spool, 8" line, 2 ea discharge line, 32 ea	\$ 16,000
8.05	Change 12" CS 900# ball valves in Master Meter skid to trunion valves	\$ 24,000
8.06	Confirm w/ meter vendor that on-line custody calibration system is Included in meter package	\$ TBD
8.08	Add 4 ea 12" CS 900# check valve downstream of XV-25954 <u>Utility P&amp;ID's</u>	\$ 60,000
1.05	Provide level switches in place of DP type level transmitters	\$ TBD

Contractor shall proceed with the above design changes and prepare detailed Lump Sum cost estimates. Upon final review and approval by Owner of the detailed estimate, Contractor shall prepare the required documentation, including a completed Schedule D-3 in accordance with Article 6.1A of the Agreement.

Compensation for the changes specified in this Change Order is on a time and materials basis as provided in Section 6.1C and 6.2D of the Agreement.

Contractor shall commence with the performance of the change(s) described above on **August 8, 2005**

---

This Change Order is signed by Owner's duly authorized representatives.

/s/ Stan Horton  
Charif Souki  
Chairman

\_\_\_\_\_  
Date of Signing

/s/ Keith Meyer  
\* Keith Meyer  
President Cheniere LNG

October 17, 2005  
Date of Signing

/s/ Stan Horton  
\* Stan Horton  
President and COO Cheniere Energy

October 17, 2005  
Date of Signing

/s/ Ed Lehotsky  
\* Ed Lehotsky  
Owner Representative

October 10, 2005  
Date of Signing

\* Required Owner signature - Mr. Horton may sign on behalf of Mr. Souki during Mr. Souki's absence.

**SCHEDULE D-1**

**CHANGE ORDER FORM**

**PROJECT NAME:** Sabine Pass LNG Receiving,  
Storage and Regasification Terminal

**CHANGE ORDER NUMBER:** SP/BE-017

**OWNER:** Sabine Pass LNG, L.P.

**DATE OF CHANGE ORDER:** 10/04/2005

**CONTRACTOR:** Bechtel Corporation

**PROJECT:** NET ZERO DOLLAR OFFSETS

**DATE OF AGREEMENT:** December 18, 2004

**The Agreement between the Parties listed above is changed as follows:**

This Change Order encompasses three separate adjustments:

- 1) As discussed between Owner and Bechtel, both Parties agree that changes for the seven items listed below under the Zero Dollar Change Order are offsetting in cost with no schedule impact.
- 2) The description for Schedule C-1 Milestone Number 6.05 is revised to correctly state the milestone description
- 3) The Monthly Payment for Schedule C-2 Month #31 is revised to correct a math error in the Payment Schedule

**Detailed Reasons for Proposed Change(s)**

The following changes have been identified and are incorporated into the project:

Zero Dollar Change Order

- 1). The Marine Berth elevation will be increased from elevation 20' to elevation 25' (Refer to Schedule A-2, Item 8.23).
- 2). The design pressure of the Reecondenser and Sendout Pump Cans will be increased to 275 psig (See attached P&ID's M6-25-00320 and 00410)
- 3). Bechtel will not claim any impact for the change in Texas law resulting in reduced bridge, allowable loads on the Highway 82 bridge (Reference letter 25025-001-T05-GAM-00100).
- 4). Bechtel will relocate the Marine Berth area 35ft to the southeast parallel to the ship channel as requested by Owner (See attached Shiner-Mosely drawing sheet 4 of 27, Rev. 1, dated 6/16/04, "Dredging Plan.")
- 5). Owner authorizes the Construction Dock dredge spoils to be pumped to the WET 16 Impoundment Area. (See attached Site Plan PI-00-00001).
- 6). The revised Site Plan including the reductions in piperack length (drawing PI-00-00001 Rev 00D) will be the basis of the project (Original basis is drawing SK-SP-00001 Rev 0F)
- 7). The paving under the piperack will be changed from concrete to crushed stone with an asphalt sealer as shown on sketch SKC-000-00001 Rev A.

Milestone Number 6.05

Schedule C-1 Milestone 6.5 Description is changed to "Commence Construction Dock Dredging."

Schedule C-2 Math Error

Schedule C-2 Month #31 Monthly Payment amount is changed to \$3,213,115 resulting in a Monthly Payment total of \$194,080,800 and a Total Payment of \$646,936,000. The Total Payment amount now equals the original Contract Price listed in the Adjustment to Contract Price section.

**Adjustment to Contract Price**

The original Contract Price was	\$	646,936,000
Net change by previously authorized Change Orders (#SP/BE-002 thru 016)	\$	24,487,544
The Contract Price prior to this Change Order was	\$	671,423,544
The Contract Price will be increased by this Change Order in the amount of	\$	Nil
The new Contract Price including this Change Order will be	\$	671,423,544

**Adjustment to dates in Project Schedule**

The following dates are modified (*list all dates modified; insert N/A if no dates modified*):

---

The Target Bonus Date will be unchanged.

The Target Bonus Date as of the date of this Change Order therefore is 1,095 Days following NTP.

The Guaranteed Substantial Completion Date will be unchanged.

The Guaranteed Substantial Completion Date as of the date of this Change Order therefore is 1,247 Days following NTP.

Adjustment to other Changed Criteria: None

Adjustment to Payment Schedule: See above

Adjustment to Minimum Acceptance Criteria: None

Adjustment to Performance Guarantees: None

Adjustment to Design Basis: See above

Other adjustments to liability or obligation of Contractor or Owner under the Agreement: None

This Change Order **shall** constitute a full and final settlement and accord and satisfaction of all effects of the change as described in this Change Order upon the Changed Criteria and shall be deemed to compensate Contractor fully for such change.

Upon execution of this Change Order by Owner and Contractor, the above-referenced change shall become a valid and binding part of the original Agreement without exception or qualification, unless noted in this Change Order. Except as modified by this and any previously issued Change Orders, all other terms and, conditions of the Agreement shall remain in full force and effect. This Change Order is executed by each of the Parties' duly authorized representatives.

/s/ Stanley Horton

\* Charif Souki  
Chairman

\_\_\_\_\_  
Date of Signing

/s/ Stan Horton

\*Stan Horton  
President & COO Cheniere Energy

October 17, 2005

Date of Signing

/s/ C. Asok Kumar

Contractor  
C. Asok Kumar

\_\_\_\_\_  
Name  
Project Manager

\_\_\_\_\_  
Title  
November 8, 2005

\_\_\_\_\_  
Date of Signing

---

\* Keith Meyer

\_\_\_\_\_  
/s/ Keith Meyer  
President Cheniere LNG

October 17, 2005

\_\_\_\_\_  
Date of Signing

/s/ Ed Lehotsky

\_\_\_\_\_  
\* Ed Lehotsky  
Owner Representative

October 11, 2005

\_\_\_\_\_  
Date of Signing

\* Required Owner signature – Mr. Horton may sign on behalf of Mr. Souki during Mr. Souki's absence.

Rev. 2

SCHEDULE D-2

UNILATERAL CHANGE ORDER FORM

PROJECT NAME: Sabine Pass LNG Receiving,  
Storage and Regasification Terminal

CHANGE ORDER NUMBER: SP/BE-018

OWNER: Sabine Pass LNG, L.P.

DATE OF CHANGE ORDER: 10/7/2005

CONTRACTOR: Bechtel Corporation

PROJECT: INCREASED PLANT ELEVATIONS

DATE OF AGREEMENT: December 18, 2004

Contractor is hereby directed to make the following additions or modifications to the Work

Plant Elevations

The elevations of the following buildings and equipment will be increased by 2 ft. from their current design elevations. Equipment elevation will increase from 14.0 ft. to 16.0 ft. MSL (17'-6" NAVD '88) and buildings from 14'-6" to 16'-6" MSL (18.0' NAVD '88)

<u>Description</u>	<u>Building / Equipment</u>
Control Room	Building
Standby Generator Set	Equipment
Gas Turbine Generators	Equipment
Transformers	Equipment
Switchgear and MCC's	Equipment
Fuel Gas Heaters	Equipment
Air Compressors	Equipment

Control Room "Safe Room"

A "safe room" will be included in the Control Room to provide a place that a skeleton crew of Operators can be safely protected from wind borne projectiles. A room does not need to be added, instead an existing room will be strengthened and so designated.

Contractor shall proceed with the above design changes and prepare the required documentation, including a completed Schedule D-3 in accordance with Article 6.1A of the Agreement. Contractor shall promptly advise Owner if the expected lump sum cost to perform the work exceeds \$1 million.

Compensation for the changes specified in this Change Order is on a time and materials basis as provided in Section 6.1C and 6.2D of the Agreement.

Contractor shall commence with the performance of the change(s) described above on **October 10, 2005**

This Change Order is signed by Owner's duly authorized representatives.

/s/ Stan Horton  
\* Charif Souki  
Chairman

/s/ Stan Horton  
Stan Horton  
President and COO Cheniere Energy

\_\_\_\_\_  
Date of Signing

October 19, 2005  
\_\_\_\_\_  
Date of Signing



---

/s/ Keith Meyer  
Keith Meyer  
President Cheniere LNG

---

/s/ Ed Lehotsky  
\* Ed Lehotsky  
Owner Representative

---

October 17, 2005  
Date of Signing

---

October 17, 2005  
Date of Signing

\* Required Owner signature - Mr. Horton may sign on behalf of Mr. Souki during Mr. Souki's absence.

Rev. 2

**SCHEDULE D-2**

**UNILATERAL CHANGE ORDER FORM**

**PROJECT NAME:** Sabine Pass LNG Receiving,  
Storage and Regasification Terminal

**CHANGE ORDER NUMBER:** SP/BE-019

**OWNER:** Sabine Pass LNG, L.P.

**DATE OF CHANGE ORDER:** 10/17/2005

**CONTRACTOR:** Bechtel Corporation

**PROJECT:** SPLNG SCOPE REVISIONS BASED ON EXPANSION AND  
CTLNG FERC REVIEWS

**DATE OF AGREEMENT:** December 18, 2004

You are hereby directed to make the following additions or modifications to, or deductions from, the Work:

Based on the Creole Trail LNG & SPLNG Expansion FERC Filing comments and the CTLNG FERC Cryogenic and Technical Conference of Aug. 10, 2005, Owner requires that the following changes be incorporated into the SPLNG Project (refer to attached list and P&ID drawings):

<b>Item</b>	<b>Description</b>
	<b>CTLNG FERC Review</b> <i>These FERC requirements flow down to Sabine LNG</i>
2.	Add LAHH and interlocks to SP-24001 & SP-24002 injectors
3.	Add minimum accuracy flow measurements to the LNG tank top & bottom fill lines
7.	Add 3" by-pass line & valve around LNG tank sendout line HV valve on top of the tanks
8.	Add 4" recycle line from the HP sendout pumps to one of the 30" unloading lines to the tank or the inter-tank transfer line
12.	Add actuator to vapor return blower suction lines
14.	Add igniter to the discretionary vents on top of the LNG tanks
17.	Add gutter type downspout from tank top LNG spill pan to direct any spilled LNG away from the CS tank side plates and funnel the LNG to grade
23.	Add back-up fire water booster pump for the LNG tank supply
25.	Add warning signs, warning lights and siren along the shore to warn local fishermen of evacuations
	<b>CTLNG FERC Filing Comments</b> <i>Also req'd for Sabine LNG</i>
a.	Add blow pot for drip leg drain on the jetty vapor return line at SP-24001 & 24002 injectors
b.	Increase sendout pump minimum flows recycle line to storage to a 900 lb rating
c.	Add blow pot to drip leg drain on the vapor return blower recycle line
d.	Add blow pot to V-104 drain for transferring liquid to LNG unloading line
e.	Ensure the spill protection system (pan) on the LNG tanks encompasses all potential leak areas inclusive of potential leak splash radius
f.	Supply can pumps with pressure transmitters on seal vents on each pump with a pressure transmitter or switch on the vent

Contractor shall proceed with the above design changes and prepare detailed Lump Sum cost estimates. Upon final review and approval by Owner of the detailed estimate, Contractor shall prepare the required documentation, including a completed Schedule D-3 in accordance with Article 6.1A of the Agreement.

Compensation for the changes specified in this Change Order is on a time and materials basis as provided in Section 6.1C and 6.2D of the Agreement.

Contractor shall commence with the performance of the change(s) described above on **October 18, 2005**

---

This Change Order is signed by Owner's duly authorized representatives.

/s/ Stan Horton  
\_\_\_\_\_  
\*Charif Souki  
Chairman

October 21, 2005  
\_\_\_\_\_  
Date of Signing

/s/ Keith Meyer  
\_\_\_\_\_  
\*Keith Meyer  
President Cheniere LNG

October 21, 2005  
\_\_\_\_\_  
Date of Signing

/s/ Stan Horton  
\_\_\_\_\_  
\*Stan Horton  
President and COO Cheniere Energy

October 21, 2005  
\_\_\_\_\_  
Date of Signing

/s/ Ed Lehotsky  
\_\_\_\_\_  
\*Ed Lehotsky  
Owner Representative

\_\_\_\_\_  
Date of Signing

\* Required Owner signature - Mr. Horton may sign on behalf of Mr. Souki during Mr. Souki's absence.

**SCHEDULE D-2**

**UNILATERAL CHANGE ORDER FORM**

**PROJECT NAME:** Sabine Pass LNG Receiving,  
Storage and Regasification Terminal

**CHANGE ORDER NUMBER:** SP/BE-020

**OWNER:** Sabine Pass LNG, L.P.

**DATE OF CHANGE ORDER:** 11/10/2005

**CONTRACTOR:** Bechtel Corporation

**PROJECT:** Sendout Control System & BOG Compressor K.O. Drum  
revisions

**DATE OF AGREEMENT:** December 18, 2004

---

**You are hereby directed to make the following additions or modifications to, or deductions from, the Work:**

**Implement the following changes:**

1. **Sendout Control System revisions as indicated in our memo of October 26, 2005 (Correspondence No. SP-BE-C-117, attached) and as shown on the attached P&ID's M6-25-00600 and M6-25-00601 (Note: block valve downstream of control valve deleted during Nov. 2 review).**
2. **BOG Compressor K.O. Drum revisions as indicated in our memo of November 4, 2005 (Correspondence No. SP-BE-C-125, attached) and as shown on the attached P&ID M6-24-00720.**

**Contractor shall proceed with the above design changes and prepare detailed Lump Sum cost estimates. Upon final review and approval by Owner of the detailed estimate, Contractor shall prepare the required documentation, including a completed Schedule D-3 in accordance with Article 6.1A of the Agreement.**

---

Compensation for the changes specified in this Change Order is on a time and materials basis as provided in Section 6.1C and 6.2D of the Agreement.

Contractor shall commence with the performance of the change(s) described above **on November 11, 2005.**

This Change Order is signed by Owner's duly authorized representatives.

/s/ Stan Horton

\*Charif Souki  
Chairman

/s/ Stan Horton

\*Stan Horton  
President and COO Cheniere Energy

November 15, 2005

Date of Signing

November 15, 2005

Date of Signing

/s/ Keith Meyer

\*Keith Meyer  
President Cheniere LNG

/s/ Ed Lehotsky

\*Ed Lehotsky  
Owner Representative

November 14, 2005

Date of Signing

November 14, 2005

Date of Signing

\* Required Owner signature - Mr. Horton may sign on behalf of Mr. Souki during Mr. Souki's absence.

**SCHEDULE D-2**

**UNILATERAL CHANGE ORDER FORM**

**PROJECT NAME:** LNG Receiving,  
Storage and Regasification Terminal

**CHANGE ORDER NUMBER:** SP/BE-021

**DATE OF CHANGE ORDER:** 11/30/2005

**OWNER:** Sabine Pass LNG, L.P.

**CONTRACTOR:** Bechtel Corporation

**DATE OF AGREEMENT:** December 18, 2004

**You are hereby directed to make the following additions or modifications to, or deductions from, the Work:**

**Implement the following Marine Berth change:**

- 1. **Provide scour protection in the lower Marine Berth below the -4.5 ft elevation shelf (refer to Bechtel transmittal SDN 25027-001-T05-GAM-00175 and plot plan, attached). Bechtel to advise Owner immediately if the cost of this change is expected to exceed the Bechtel OOM estimate of \$5MM.**

**Contractor shall proceed with the above design change and prepare detailed Lump Sum cost estimate. Upon final review and approval by Owner of the detailed estimate, Contractor shall prepare the required documentation, including a completed Schedule D-3 in accordance with Article 6.1A of the Agreement.**

Compensation for the changes specified in this Change Order is on a time and materials basis as provided in Section 6.1C and 6.2D of the Agreement.

Contractor shall commence with the performance of the change(s) described above **on November, 30, 2005**

This Change Order is signed by Owner's duly authorized representatives.

\_\_\_\_\_  
 /s/ Charif Souki  
 \* Charif Souki  
 Chairman

\_\_\_\_\_  
 /s/ Stan Horton  
 \* Stan Horton  
 President and COO Cheniere Energy

\_\_\_\_\_  
Date of Signing

\_\_\_\_\_  
Date of Signing

\_\_\_\_\_  
 /s/ Keith Meyer  
 \* Keith Meyer  
 President Cheniere LNG

\_\_\_\_\_  
 /s/ Ed Lehotsky  
 \* Ed Lehotsky  
 Owner Representative

\_\_\_\_\_  
 December 7, 2005  
 Date of Signing

\_\_\_\_\_  
 December 5, 2005  
 Date of Signing

\* Required Owner signature - Mr. Horton may sign on behalf of Mr. Souki during Mr. Souki's absence.

**SCHEDULE D-1**

**CHANGE ORDER FORM**

(for use when the Parties mutually agree upon and execute the Change Order pursuant to Section 6.1B or 6.2C)

**PROJECT NAME:** Sabine Pass LNG Receiving,  
Storage and Regasification Terminal

**CHANGE ORDER NUMBER:** SP/BE-022

**DATE OF CHANGE ORDER:** December 16, 2005

**OWNER:** Sabine Pass LNG, L.P.

**Increase Sendout Pressure to 1440 PSIG**

**CONTRACTOR:** Bechtel Corporation

**DATE OF AGREEMENT:** December 18, 2004

**The Agreement between the Parties listed above is changed as follows:**

This Change Order, as agreed to by Owner and Contractor, replaces Owner's Unilateral Change Order SP/BE-001 dated January 18, 2005.

Scope of Work:

Increase Sendout Pressure of the Natural Gas as measured at the back pressure Control Valve located just upstream of the Master Meter from 1250 psig to 1440 psig.

Three (3) GE LM2500+[DLE] GTG's will be purchased in lieu of five (5) Solar GTG's. Space and foundations will be provided for the future installation of inlet air chilling and waste heat recovery.

Other major equipment includes:

- Sendout pump modifications and motor changes - 17 each including warehouse spare (HP change from 2100 to maximum 2,535 HP)
- Fuel Gas Heater change from 185 KW to 635 KW - 3 each
- Standby Diesel Generator change from 1 unit (2.5MW) to 2 units (1.5 MW each)

Civil / Structural

Increase foundation sizes for Sendout Pumps, FG Heaters and HP Vent Stack

Piping & Instruments

Revise all piping and control valves downstream of the Sendout Back pressure Control Valve from 600# to 900# class.

Electrical

Increase cable size for higher sendout motors HP.

See attached documents for cost summary:

"Cost Evaluation Summary" dated December 9, 2005, 1 page

"Detail Estimate" Trend T-004 R4, dated December 9, 2005, 6 pages

"Detail Estimate" Trend T-0045, dated December 9, 2005, 8 pages

**Adjustment to Contract Price**

The original Contract Price was	\$ 646,936,000
Net change by previously authorized Change Orders (thru CO#SP/BE-017)	\$ 24,487,544
The Contract Price prior to this Change Order was	\$ 671,423,544
The Contract Price will be increased by this Change Order in the amount of	\$ 37,376,851
The new Contract Price including this Change Order will be	\$ 708,800,395

**Adjustment to dates in Project Schedule**

The following dates are modified (*list all dates modified; insert N/A if no dates modified*):

The Target Bonus Date will be unchanged.

The Target Bonus Date as of the date of this Change Order therefore is 1,095 Days following NTP.

The Guaranteed Substantial Completion Date will be unchanged.

The Guaranteed Substantial Completion Date as of the date of this Change Order therefore is 1,247 Days following NTP.

Adjustment to other Changed Criteria: "Target Completion" defined in Article 1, Definitions, is revised as follows:

**"Target Completion"** means that all of the following have occurred with respect to the Facility: (i) Cool Down has been completed for System 1 and System 2; (ii) Contractor has completed all procurement, fabrication, assembly, erection, installation and pre-commissioning checks of all of the vaporizers for the Facility to ensure that all such vaporizers and each component thereof was sufficiently fabricated, assembled, erected and installed so as to be capable of being operated safely within the requirements contained in this Agreement, and thirteen vaporizers have been operated to their rated capacity; (iii) Contractor has completed all procurement, fabrication, assembly, erection, installation and pre-commissioning checks and tests of System 1 and System 2 to ensure that these Systems and each component thereof was sufficiently fabricated, assembled, erected and installed so as to be capable of being operated safely within the requirements contained in this Agreement; and (iv) System 1 and System 2 collectively achieve a Sendout Rate of 2,000 MMSCFD or above at a temperature of no less than 40°F and at a pressure of no less than 1,420 PSIG as measured at the exit for the main Facility transfer meter, for a continuous period of a minimum of twenty-four (24) hours.

Adjustment to Payment Schedule: See attached Payment Schedule, "Increased Sendout Pressure from 1250 to 1440 PSIG - Phase I and II," dated December 9, 2005, 1 page.

Adjustment to Minimum Acceptance Criteria: The following sections are replaced:

**Attachment T**

2. Minimum Acceptance Criteria

- A. Sendout Rate. The Facility shall vaporize LNG for twenty four (24) continuous hours at an average rate of 2,400 MMSCFD or above (the "Sendout Rate MAC") at a temperature of no less than 40°F and at a pressure of no less than 1,440 PSIG, using no more than fifteen (15) vaporizers; provided that the Sendout Rate Guarantee Conditions stipulated in Section 4 of this Attachment T are met.

Adjustment to Performance Guarantees: The following sections are replaced:

**Attachment T**

3. Performance Guarantees

- A. Sendout Rate Performance Guarantee. The Facility shall vaporize LNG for twenty four (24) continuous hours at an average Sendout Rate of 2,670 MM SCFD (the "**Sendout Rate Performance Guarantee**") at a temperature of no less than 40°F and at a pressure of no less than 1,440 PSIG, using no more than fifteen (15) vaporizers; provided that the Sendout Rate Guarantee Conditions stipulated in Section 4 of this Attachment T are met.

4. Guarantee Conditions.

A. Sendout Rate Guarantee Conditions. The conditions upon which the Sendout Rate MAC and the Sendout Rate Performance Guarantee (the "Sendout Rate Guarantee Conditions") are based are as follows:

- (i) The sendout pressure of the Natural Gas shall be measured directly upstream of the back-pressure control valve located just upstream of the Master Meter, as described in Section 1C of Attachment S. The temperature of the Natural Gas shall be at a pressure of no less than 1420 psig as measured at the exit for the main Facility transfer meter.
- (iii) The maximum allowable operating pressure of Natural Gas in the Export Pipeline will be 1,440 PSIG.

6. Delay Liquidated Damages

B. Substantial Completion Delay Liquidated Damages ("Substantial Completion Delay Liquidation Damages").

- 2. The Substantial Completion Delay Liquidated Damages set forth in Section 6.B.1 of this Attachment T shall be reduced to the following amounts if only System 1 achieves, on or before the Guaranteed Substantial Completion Date, a Sendout Rate of 1,250 MMSCFD or above at a temperature of no less than 40°F and at a pressure of no less than 1,440 PSIG, and based on the use of no more than seven (7) vaporizers plus one (1) spare vaporizer; *provided that* the Sendout Rate Guarantee Conditions stipulated in Section 4 of this Attachment T are met:
  - a. Sixty Thousand U.S. Dollars (U.S. \$60,000) per Day from 1 Day to and including 15 Days after Guaranteed Substantial Completion Date, plus
  - b. One Hundred Twenty Thousand U.S. Dollars (U.S. \$120,000) per Day from 16 Days to and including 30 Days after Guaranteed Substantial Completion Date, plus
  - c. Two Hundred Thirty-five Thousand U.S. Dollars (U.S. \$235,000) per Day from 31 Days and more after Guaranteed Substantial Completion Date.
- 3. The Substantial Completion Delay Liquidated Damages set forth in Section 6.B.1 of this Attachment T shall be reduced to the following amounts if System 1 and System 2 collectively achieve, on or before the Guaranteed Substantial Completion Date, a Sendout Rate of 2,000 MMSCFD or above at a temperature of no less than 40°F and at a pressure of no less than 1,440 PSIG, and based on the use of no more than twelve (12) vaporizers plus one (1) spare vaporizer; *provided that* the Sendout Rate Guarantee Conditions stipulated in Section 4 of this Attachment T are met:
  - a. Thirty Thousand U.S. Dollars (U.S. \$30,000) per Day from 1 Day to and including 15 Days after Guaranteed Substantial Completion Date, plus
  - b. Sixty Thousand U.S. Dollars (U.S. \$60,000) per Day from 16 Days to and including 30 Days after Guaranteed Substantial Completion Date, plus
  - c. One Hundred Twenty Thousand U.S. Dollars (U.S. \$120,000) per Day from 31 Days and more after Guaranteed Substantial Completion Date.



Adjustment to Design Basis: The following sections are replaced or amended:

Attachment A Schedule A-2

	<u>Item</u>	<u>Design Basis</u>	<u>Remarks</u>	<u>DESIGN REQT</u>	<u>RELY UPON</u>
1.7	Battery limit Natural Gas pressure requirement	1440 psig at Guaranteed Sendout Rate downstream of Master Meter	At battery limit	Yes	
14.3	Maximum Allowable Operating Pressure (MAOP)	1440 psig			Yes

Item 14.4 Operating Pressure is deleted from the Design Basis

Incorporate the following attached Drawings:

- PFD M5-DK-00002 Rev.1 (Markup showing piping Flange Class changes)
- PFD M5-DK-00003 Rev.0 (Indicating deletion of GTG scope based on the Titan GTGs)
- PFD-M5-DK-00003 Rev. 1 (Indicating New GTG scope based on G.E. GTGs)
- SK-SP-1000 Rev. 0A (Overall Electrical One-Line Diagram indicating electrical work scope based on Titan GTGs)
- EI-10-00004 Rev.00D (Overall Electrical One-Line Diagram indicating electrical work scope based on G.E. GTGs)

Other adjustments to liability or obligation of Contractor or Owner under the Agreement: None

This Change Order shall constitute a full and final settlement and accord and satisfaction of all effects of the change as described in this Change Order upon the Changed Criteria and shall be deemed to compensate Contractor fully for such change; provided, however, that pursuant to Article 6.4 this Change Order does not include nor satisfy in any manner the following additional items for which Contractor reserves the right to submit Change Orders in this regard in accordance with the terms of the Agreement.

- Overtime for workers not directly involved with installation of the Combustion Gas Turbines and associated equipment and facilities
- Costs or other adjustments for decreased productivity caused by extended overtime
- The Parties acknowledge that the consequences arising out of, relating to, or resulting from Hurricanes Katrina, Rita and Wilma have not been fully evaluated.

Upon execution of this Change Order by Owner and Contractor, the above-referenced change shall become a valid and binding part of the original Agreement without exception or qualification, unless noted in this Change Order. Except as modified by this and any previously issued Change Orders, all other terms and conditions of the Agreement shall remain in full force and effect. This Change Order is executed by each of the Parties' duly authorized representatives.

/s/ Stan Horton  
\* Charif Souki  
Chairman

/s/ C. Asok Kumar  
Contractor

C. Asok Kumar  
Name  
Project Director  
Title  
December 21, 2005  
Date of Signing

December 20, 2005

---

/s/ Stan Horton

\* Stan Horton  
President & COO Cheniere Energy

December 20, 2005

Date of Signing

/s/ Keith Meyer

\* Keith Meyer  
President Cheniere LNG

December 21, 2005

Date of Signing

/s/ Ed Lehotsky

\* Ed Lehotsky  
Owner Representative

December 20, 2005

Date of Signing

\*Required Owner signature - Mr. Horton may sign on behalf of Mr. Souki during Mr. Souki's absence.

**SCHEDULE D-1**

**CHANGE ORDER FORM**

**PROJECT NAME:** Sabine Pass LNG Receiving,  
Storage and Regasification Terminal

**CHANGE ORDER NUMBER:** SP/BE-023

**OWNER:** Sabine Pass LNG, L.P.

**DATE OF CHANGE ORDER:** January 20, 2006

**CONTRACTOR:** Bechtel Corporation

**P&ID AND CAUSE & EFFECT OPTIONS**

**DATE OF AGREEMENT:** December 18, 2004

**The Agreement between the Parties listed above is changed as follows:**

This Change Order, as agreed to by Owner and Contractor, replaces Owner's Unilateral Change Order SP/BE-012 dated July 12, 2005.

In accordance with Owner's Unilateral Change Order Number SP/BE-012, dated July 12, 2005, covering P&ID cause and effect scope option items, as amended by Owner letters SP-BE-C-110 (deleted Items 4.16 and 20.06) and SP-BC-C-132 (deleted Items 18.05 and 19.06) and miscellaneous scope changes directed by Owner during the IFA P&ID review meeting during April 2005, as shown in the attached marked up drawings, Contractor shall implement and incorporate the following:

**P&ID Review Scope Changes**

- Add local and remote actuators on manual valves in Lines 16" FGN-24080, 24"DK-24021 and 16" FGN-24620 (Ref. SP/BE-012, Item 3.06)
- Add three 30" automated access entry valves with actuator and positioners (Ref. SP/BE-012, Item 7.04)
- Add a total of three surge tanks to nitrogen snuffing system, one each on top of each LNG Tank, increase piping size from 2" to 3", and increase controls valve sizes to 3" (Ref. SP/BE-012, Item 9.03)
- Add 6" stainless steel insulated bi-directional jumper (Line No. 6"-GPL-25049-NO-C7.0") with remotely actuated ball valve to 6" DK-25119 between recondensers (Ref. SP/BE-012, Item 13.01)
- Delete LP vent stack Z-102, including bulks, and delete 30" line from 2R rack to vent and associated piping and valves in tank area (Ref. SP/BE-012, Item 19.06). One 12" vent per tank will be included in the HAZOP Change Order when issued.
- Add 24" bypass upstream of in-tank discharge header manual block valve and jump to common 30" unloading header (Ref. SP/BE-012, Item 10.04)
- Add switch to control room (Ref. SP/BE-012, Item 20.05)

**Cause & Effect Scope Changes**

- Add 16 each 3/4" x 1" 900 lb. PSVs (thermal relief valves) with isolations valves, inlet and discharge piping (Ref. SP/BE-012, Item 10.00)

Reference attached "Trend T-0025 - Detail Estimate for P&ID and Cause & Effect Scope Changes," 14 pages, dated January 3, 2006, for details.

**Adjustment to Contract Price**

The original Contract Price was	\$	646,936,000
Net change by previously authorized Change Orders (#SP/BE-001 thru 022)	\$	61,864,395
The Contract Price prior to this Change Order was	\$	708,800,395
The Contract Price will be increased by this Change Order in the amount of	\$	469,544
The new Contract Price including this Change Order will be	\$	709,269,939

**SCHEDULE D-1**

**CHANGE ORDER FORM**

**PROJECT NAME:** Sabine Pass LNG Receiving,  
Storage and Regasification Terminal

**CHANGE ORDER NUMBER:** SP/BE-023

**OWNER:** Sabine Pass LNG, L.P.

**DATE OF CHANGE ORDER:** January 20, 2006

**CONTRACTOR:** Bechtel Corporation

**P&ID AND CAUSE & EFFECT OPTIONS**

**DATE OF AGREEMENT:** December 18, 2004

---

**Adjustment to dates in Project Schedule**

The following dates are modified:

The Target Bonus Date will be unchanged.

The Target Bonus Date as of the date of this Change Order therefore is 1,095 Days following the NTP.

The Guaranteed Substantial Completion Date will be unchanged.

The Guaranteed Substantial Completion Date as of the date of this Change Order therefore is therefore 1,247 Days following NTP.

Adjustment to other Changed Criteria: Not Applicable

Adjustment to Payment Schedule: See attached "Payment Milestones—P&ID Changes—Cause & Effect," dated January 3, 2006, 1 page

Adjustment to Minimum Acceptance Criteria: No Change

Adjustment to Performance Guarantees: No Change

Adjustment to Design Basis: Yes, as modified by this Change Order

Other adjustments to liability or obligation of Contractor or Owner under the Agreement: No Change

This Change Order **shall** constitute a full and final settlement and accord and satisfaction of all effects of the change as described in this Change Order upon the Changed Criteria and shall be deemed to compensate Contractor fully for such change.

Upon execution of this Change Order by Owner and Contractor, the above-referenced change shall become a valid and binding part of the original Agreement without exception or qualification, unless noted in this Change Order. Except as modified by this and any previously issued Change Orders, all other terms and conditions of the Agreement shall remain in full force and effect. This Change Order is executed by each of the Parties, duly authorized representatives.

**SCHEDULE D-1**

**CHANGE ORDER FORM**

**PROJECT NAME:** Sabine Pass LNG Receiving,  
Storage and Regasification Terminal

**CHANGE ORDER NUMBER:** SP/BE-023

**OWNER:** Sabine Pass LNG, L.P.

**DATE OF CHANGE ORDER:** January 20, 2006

**CONTRACTOR:** Bechtel Corporation

**P&ID AND CAUSE & EFFECT OPTIONS**

**DATE OF AGREEMENT:** December 18, 2004

/s/ Stan Horton

\* Charif Souki  
Chairman

Contractor

Name

February 6, 2006

Date of Signing

Title

Date of Signing

/s/ Stan Horton

\*Stan Horton  
President & COO Cheniere Energy

February 6, 2006

Date of Signing

/s/ Keith Meyer

\*Keith Meyer  
President Cheniere LNG

January 31, 2006

Date of Signing

/s/ Ed Lehotsky

\*Ed Lehotsky  
Owner Representative

January 25, 2006

Date of Signing

\* Required Owner signature - Mr. Horton may sign on behalf of Mr. Souki during Mr. Souki's absence.

---

**SCHEDULE D-1**

**CHANGE ORDER FORM**

**PROJECT NAME:** Sabine Pass LNG Receiving,  
Storage and Regasification Terminal

**CHANGE ORDER NUMBER:** SP/BE-024

**OWNER:** Sabine Pass LNG, L.P.

**DATE OF CHANGE ORDER:** January 20, 2006

**CONTRACTOR:** Bechtel Corporation

**SCV OPTIONS (EXCLUDING PLC vs. DCS)**

**DATE OF AGREEMENT:** December 18, 2004

---

**The Agreement between the Parties listed above is changed as follows:**

This Change Order, as agreed to by Owner and Contractor, replaces Owner's Unilateral Change Order SP/BE-013 dated July 18, 2005.

In accordance with the EPC Agreement, Attachment A, Schedule A-1, Section 13.2, Owner's Unilateral Change Order Number SP/BE-013, dated July 18, 2005, and Bechtel Letter 25027-GAM-T05-00117 (Items 1, 4 and 8 only), Contractor shall implement and incorporate the following SCV options:

- 1) Two (2) each stainless steel SS 3" diameter blind block / check valves for taking water circulation pump out of service, with blinded tee and solenoid valve for future connection of utility water. These exclude future utility water piping, wiring from MCC starter to solenoid valve, and extra terminal on the motor starter.
- 2) Provide vaporizer modifications on all sixteen (16) SCV units to accommodate a hot water sparger in the water bath for waste heat recovery from gas turbine exhaust.
- 3) Sixteen (16) each 42' exhaust stacks in SS rather than painted CS.

This Change Order does not incorporate Item 3 (Replace PLC with DCS) in Bechtel letter 25027-GAM-T05-00117. Per Owner's direction on December 22, 2005, this will be addressed separately once the DCS supplier is selected.

Reference attached "Trend T-0020b - Detail Estimate for SCV Options (Excludes PLC vs. DCS Options)," 1 page, dated August 4, 2005, for details.

---

**Adjustment to Contract Price**

The original Contract Price was	\$ 646,936,000
Net change by previously authorized Change Orders (#SP/BE-001 thru 023)	\$ 62,333,939
The Contract Price prior to this Change Order was	\$ 709,269,939
The Contract Price will be increased by this Change Order in the amount of	\$ 1,340,000
The new Contract Price including this Change Order will be	\$ 710,609,939

---

**SCHEDULE D-1**

**CHANGE ORDER FORM**

**PROJECT NAME:** Sabine Pass LNG Receiving,  
Storage and Regasification Terminal

**CHANGE ORDER NUMBER:** SP/BE-024

**OWNER:** Sabine Pass LNG, L.P.

**DATE OF CHANGE ORDER:** January 20, 2006

**CONTRACTOR:** Bechtel Corporation

**SCV OPTIONS (EXCLUDING PLC vs. DCS)**

**DATE OF AGREEMENT:** December 18, 2004

---

**Adjustment to dates in Project Schedule**

The following dates are modified:

The Target Bonus Date will be unchanged.

The Target Bonus Date as of the date of this Change Order therefore is 1,095 Days following the NTP.

The Guaranteed Substantial Completion Date will be unchanged.

The Guaranteed Substantial Completion Date as of the date of this Change Order therefore is therefore 1,247 Days following NTP.

Adjustment to other Changed Criteria: Not Applicable

Adjustment to Payment Schedule: See attached "Payment Milestones - SCV Options," dated December 22, 2005, 1 page

Adjustment to Minimum Acceptance Criteria: No Change

Adjustment to Performance Guarantees: No Change

Adjustment to Design Basis: Yes, as modified by this Change Order

Other adjustments to liability or obligation of Contractor or Owner under the Agreement: No Change

This Change Order **shall** constitute a full and final settlement and accord and satisfaction of all effects of the change as described in this Change Order upon the Changed Criteria and shall be deemed to compensate Contractor fully for such change.

Upon execution of this Change Order by Owner and Contractor, the above-referenced change shall become a valid and binding part of the original Agreement without exception or qualification, unless noted in this Change Order. Except as modified by this and any previously issued Change Orders, all other terms and conditions of the Agreement shall remain in full force and effect. This Change Order is executed by each of the Parties' duly authorized representatives.

**SCHEDULE D-1**

**CHANGE ORDER FORM**

**PROJECT NAME:** Sabine Pass LNG Receiving,  
Storage and Regasification Terminal

**CHANGE ORDER NUMBER:** SP/BE-024

**OWNER:** Sabine Pass LNG, L.P.

**DATE OF CHANGE ORDER:** January 20, 2006

**CONTRACTOR:** Bechtel Corporation

**SCV OPTIONS (EXCLUDING PLC vs. DCS)**

**DATE OF AGREEMENT:** December 18, 2004

/s/Stan Horton

\* Charif Souki  
Chairman

February 6, 2006

Date of Signing

/s/Stan Horton

\* Stan Horton  
President & COO Cheniere Energy

February 6, 2006

Date of Signing

/s/Keith Meyer

Keith Meyer  
President Cheniere LNG

January 31, 2006

Date of Signing

/s/Ed Lehotsky

\* Ed Lehotsky  
Owner Representative

January 23, 2006

Date of Signing

\* Required Owner signature - Mr. Horton may sign on behalf of Mr. Souki during Mr. Souki's absence.

Contractor

Name

Title

Date of Signing



**SCHEDULE D-1**

**CHANGE ORDER FORM**

**PROJECT NAME:** Sabine Pass LNG Receiving,  
Storage and Regasification Terminal

**CHANGE ORDER NUMBER:** SP/BE-025

**OWNER:** Sabine Pass LNG, L.P.

**DATE OF CHANGE ORDER:** January 20, 2006

**CONTRACTOR:** Bechtel Corporation

**MISCELLANEOUS OWNER CHANGES**

**DATE OF AGREEMENT:** December 18, 2004

**This Agreement between the Parties listed above is changed as follows:**

1. SVT Unloading Arms:
  - a. Provide 8 total 16" ANSI 150# Special Alloy blind flanges for Unloading Arms in lieu of base SVT offering of 16" standard light weight aluminum blind flanges.
  - b. Provide 2 total Allen-Bradley ControlLogix PLC including RSLogix 5000 program software in lieu of SVT's standard PLC
2. IHI BOG Compressor:
  - a. Provide 3 total Allen-Bradley Control Logix PLC including RSLogix 5000 program software in lieu off IHI's standard PLC
3. Owner Site Construction Office Expansion:
  - a. Provide expanded office as per Owner (SPLNG Team) requirements on a "Lease Options" basis (refer to Correspondence No. SP-BE-C-116, attached).
4. Send Out System Check Valves
  - a. Provide 32 each 8" and 16 each 10" Grayloc Hub end Check Valves (including 2 each connectors and gaskets per valve) in lieu of the same quantity of Butt Weld Wafer Check Valves (refer to Correspondence No. SP-BE-C-119, attached).

Reference attached "Trend Summary - Miscellaneous Bundle Change Order," 4 pages, dated January 4, 2006, for details.

**Adjustment to Contract Price**

The original Contract Price was	\$ 646,936,000
Net change by previously authorized Change Orders (#SP/BE-001 thru 017 & 22)	\$ 63,673,939
The Contract Price prior to this Change Order was	\$ 710,609,939
The Contract Price will be increased by this Change Order in the amount of	\$ 420,636
The new Contract Price including this Change Order will be	\$ 711,030,575

---

**SCHEDULE D-1**

**CHANGE ORDER FORM**

**PROJECT NAME:** Sabine Pass LNG Receiving,  
Storage and Regasification Terminal

**CHANGE ORDER NUMBER:** SP/BE-025

**OWNER:** Sabine Pass LNG, L.P.

**DATE OF CHANGE ORDER:** January 20, 2006

**CONTRACTOR:** Bechtel Corporation

**MISCELLANEOUS OWNER CHANGES**

**DATE OF AGREEMENT:** December 18, 2004

---

**Adjustment to dates in Project Schedule**

The following dates are modified:

The Target Bonus Date will be unchanged.

The Target Bonus Date as of the date of this Change Order therefore is 1,095 Days following the NTP.

The Guaranteed Substantial Completion Date will be unchanged.

The Guaranteed Substantial Completion Date as of the date of this Change Order therefore is therefore 1,247 Days following NTP.

Adjustment to other Changed Criteria: Not Applicable

Adjustment to Payment Schedule: See attached "CI - Milestone Payment Schedule," dated January 4, 2006, 1 page

Adjustment to Minimum Acceptance Criteria: No Change

Adjustment to Performance Guarantees: No Change

Adjustment to Design Basis: Yes, as modified by this Change Order.

Other adjustments to liability or obligation of Contractor or Owner under the Agreement: No Change

This Change Order **shall** constitute a full and final settlement and accord and satisfaction of all effects of the change as described in this Change Order upon the Changed Criteria and shall be deemed to compensate Contractor fully for such change.

Upon execution of this Change Order by Owner and Contractor, the above-referenced change shall become a valid and binding part of the original Agreement without exception or qualification, unless noted in this Change Order. Except as modified by this and any previously issued Change Orders, all other terms and conditions of the Agreement shall remain in full force and effect. This Change Order is executed by each of the Parties' duly authorized representatives.

**SCHEDULE D-1**

**CHANGE ORDER FORM**

**PROJECT NAME:** Sabine Pass LNG Receiving,  
Storage and Regasification Terminal

**CHANGE ORDER NUMBER:** SP/BE-025

**OWNER:** Sabine Pass LNG, L.P.

**DATE OF CHANGE ORDER:** January 20, 2006

**CONTRACTOR:** Bechtel Corporation

**MISCELLANEOUS OWNER CHANGES**

**DATE OF AGREEMENT:** December 18, 2004

\_\_\_\_\_  
/s/ Stan Horton  
\* Charif Souki  
Chairman

\_\_\_\_\_  
Contractor

\_\_\_\_\_  
February 16, 2006  
Date of Signing

\_\_\_\_\_  
Name

\_\_\_\_\_  
Title

\_\_\_\_\_  
/s/ Stan Horton  
\*Stan Horton  
President & COO Cheniere Energy

\_\_\_\_\_  
Date of Signing

\_\_\_\_\_  
February 16, 2005  
Date of Signing

\_\_\_\_\_  
/s/ Keith Meyer  
\*Keith Meyer  
President Cheniere LNG

\_\_\_\_\_  
January 31, 2006  
Date of Signing

\_\_\_\_\_  
/s/ Ed Lehotsky  
\*Ed Lehotsky  
Owner Representative

\_\_\_\_\_  
January 23, 2006  
Date of Signing

\* Required Owner signature - Mr. Horton may sign on behalf of Mr. Souki during Mr. Souki's absence.

---

**SCHEDULE D-1**

**CHANGE ORDER FORM**

**PROJECT NAME:** Sabine Pass LNG Receiving,  
Storage and Regasification Terminal

**CHANGE ORDER NUMBER:** SP/BE-026

**OWNER:** Sabine Pass LNG, L.P.  
**CONTRACTOR:** Bechtel Corporation

**DATE OF CHANGE ORDER:** January 20, 2006

**DATE OF AGREEMENT:** December 18, 2004

**MEAN SEA LEVEL vs. NAVD 88 DESIGN BASIS CLARIFICATION**

---

**The Agreement between the Parties listed above is changed as follows:**

In accordance with Owner's letters SP-BE-C-108 dated October 6, 2005, Contractor shall implement and incorporate the additional elevation required to meet Owner's Mean Sea Level design requirement clarification. Contractor shall raise the permanent plant equipment and pipe racks and buildings an additional 1.4 feet.

Reference attached "Trend T-0054 Rev. 3 - Detail Estimate for Design Basis for Elevation of Plant Facilities (NAVD 88 vs. MSL)," 1 page, dated January 4, for details.

---

**Adjustment to Contract Price**

The original Contract Price was	\$ 646,936,000
Net change by previously authorized Change Orders (#SP/BE-001 thru 025)	\$ 64,094,575
The Contract Price prior to this Change Order was	\$ 711,030,575
The Contract Price will be increased by this Change Order in the amount of	\$ 100,000
The new Contract Price including this Change Order will be	\$ 711,130,575

---

**Adjustment to dates in Project Schedule**

The following dates are modified:

The Target Bonus Date will be unchanged.

The Target Bonus Date as of the date of this Change Order therefore is 1,095 Days following the NTP.

The Guaranteed Substantial Completion Date will be unchanged.

The Guaranteed Substantial Completion Date as of the date of this Change Order therefore is therefore 1,247 Days following NTP.

Adjustment to other Changed Criteria: Not Applicable

Adjustment to Payment Schedule: See attached "Payment Milestones - Design Basis for Elevation of Plant Facilities (NAVD 88 vs. MSL)," dated January 4, 2006, 1 page

Adjustment to Minimum Acceptance Criteria: No Change

Adjustment to Performance Guarantees: No Change

Adjustment to Design Basis: Yes, as modified by this Change Order

**SCHEDULE D-1**

**CHANGE ORDER FORM**

**PROJECT NAME:** Sabine Pass LNG Receiving,  
Storage and Regasification Terminal

**CHANGE ORDER NUMBER:** SP/BE-026

**OWNER:** Sabine Pass LNG, L.P.  
**CONTRACTOR:** Bechtel Corporation

**DATE OF CHANGE ORDER:** January 20, 2006

**DATE OF AGREEMENT:** December 18, 2004

**MEAN SEA LEVEL vs. NAVD 88 DESIGN BASIS CLARIFICATION**

**Adjustment to dates in Project Schedule (*cont'd*)**

Other adjustments to liability or obligation of Contractor or Owner under the Agreement: No Change

This Change Order **shall** constitute a full and final settlement and accord and satisfaction of all effects of the change as described in this Change Order upon the Changed Criteria and shall be deemed to compensate Contractor fully for such change.

Upon execution of this Change Order by Owner and Contractor, the above-referenced change shall become a valid and binding part of the original Agreement without exception or qualification, unless noted in this Change Order. Except as modified by this and any previously issued Change Orders, all other terms and conditions of the Agreement shall remain in full force and effect. This Change Order is executed by each of the Parties' duly authorized representatives.

/s/ Stan Horton

\* Charif Souki  
Chairman

Contractor

Name

February 6, 2006

Date of Signing

Title

Date of Signing

/s/ Stan Horton

\*Stan Horton  
President & COO Cheniere Energy

February 6, 2006

Date of Signing

/s/ Keith Meyer

\*Keith Meyer  
President Cheniere LNG

January 31, 2006

Date of Signing

---

**SCHEDULE D-1**

**CHANGE ORDER FORM**

**PROJECT NAME:** Sabine Pass LNG Receiving,  
Storage and Regasification Terminal

**CHANGE ORDER NUMBER:** SP/BE-026

**OWNER:** Sabine Pass LNG, L.P.

**DATE OF CHANGE ORDER:** January 20, 2006

**CONTRACTOR:** Bechtel Corporation

**MEAN SEA LEVEL vs. NAVD 88 DESIGN BASIS CLARIFICATION**

**DATE OF AGREEMENT:** December 18, 2004

---

/s/ Ed Lehotsky

\*Ed Lehotsky  
Owner Representative

January 23, 2006

Date of Signing

\* Required Owner signature - Mr. Horton may sign on behalf of Mr. Souki during Mr. Souki's absence.

**SCHEDULE D-1**  
**CHANGE ORDER FORM**

**PROJECT NAME:** Sabine Pass LNG Receiving,  
Storage and Regasification Terminal

**CHANGE ORDER NUMBER:** SP/BE-027

**DATE OF CHANGE ORDER:** January 20, 2006

**OWNER:** Sabine Pass LNG, L.P.

**INCREASE PLANT ELEVATIONS & ADD CONTROL BUILDING "SAFE ROOM"**

**CONTRACTOR:** Bechtel Corporation

**DATE OF AGREEMENT:** December 18, 2004

---

**The Agreement between the Parties listed above is changed as follows:**

This Change Order replaces Unilateral Change Order SP/BE-018 dated October 7, 2005.

In accordance with Owner's decision after Hurricanes Katrina and Rita to address storm surge concerns, Contractor agrees to implement and incorporate the following Owner directed changes:

- 1.) New elevation for equipment (standby generator set, gas turbine generators and transformers, switchgear and Motor Control Centers, fuel gas heaters and air compressors) will be increased by 2 feet from their current design elevations from 14' - 0" to 16' - 0" MSL (17' - 6" NAVD '88)
- 2.) New elevation for the Control Room building will be increased by 2' from its current design elevation from 14' - 6" to 16' - 6" MSL (18' - 0" NAVD '88).
- 3.) Upgrade and strengthen an existing room in the Control Room and designate it as a "safe room" in order to afford safety protection to a skeleton crew of operators from wind borne projectiles.

Reference following attached documents for details:

- 1) "Trend T-0080 Rev. 3 - Increased Plant Elevation for Control Room and Selected Equipment," 2 pages, dated January 11, 2006,
- 2) Bechtel Sketch titled "Process Area - 2' Elevation Increase," 1 page, dated October 3, 2005
- 3) Bechtel Drawing A1-4A1-00001 titled "Architectural Control Bldg A-101 (with note on Safe Room 110)," 1 page, dated December 13, 2005.
- 4) Bechtel Conference Notes 25027-001-G15-GAM-00094 dated September 27, 2005

---

**Adjustment to Contract Price**

The original Contract Price was	\$ 646,936,000
Net change by previously authorized Change Orders (#SP/BE-001 thru 026)	\$ 64,194,575
The Contract Price prior to this Change Order was -	\$ 711,130,575
The Contract Price will be increased by this Change Order in the amount of	\$ 650,033
The new Contract Price including this Change Order will be	\$ 711,780,608

---

---

**SCHEDULE D-1**  
**CHANGE ORDER FORM**

**PROJECT NAME:** Sabine Pass LNG Receiving,  
Storage and Regasification Terminal

**CHANGE ORDER NUMBER:** SP/BE-027

**OWNER:** Sabine Pass LNG, L.P.

**DATE OF CHANGE ORDER:** January 20, 2006

**CONTRACTOR:** Bechtel Corporation

**INCREASE PLANT ELEVATIONS & ADD**

**DATE OF AGREEMENT:** December 18, 2004

**CONTROL BUILDING "SAFE ROOM"**

---

**Adjustment to dates in Project Schedule**

The following dates are modified:

The Target Bonus Date will be unchanged.

The Target Bonus Date as of the date of this Change Order therefore is 1,095 Days following the NTP.

The Guaranteed Substantial Completion Date will be unchanged.

The Guaranteed Substantial Completion Date as of the date of this Change Order therefore is therefore 1,247 Days following NTP.

Adjustment to other Changed Criteria: Not Applicable

Adjustment to Payment Schedule: See attached "Payment Milestones – Increased Plant Elevation for Control Room / Selected Equipment plus Control Room "Safe Room." 1 page, dated January 11, 2006,

Adjustment to Minimum Acceptance Criteria: No Change

Adjustment to Performance Guarantees: No Change

Adjustment to Design Basis: Yes, as modified by this Change Order

Other adjustments to liability or obligation of Contractor or Owner under the Agreement: No Change

---

This Change Order **shall** constitute a full and final settlement and accord and satisfaction of all effects of the change as described in this Change Order upon the Changed Criteria and shall be deemed to compensate Contractor fully for such change.

Upon execution of this Change Order by Owner and Contractor, the above-referenced change shall become a valid and binding part of the original Agreement without exception or qualification, unless noted in this Change Order. Except as modified by this and any previously issued Change Orders, all other terms and conditions of the Agreement shall remain in full force and effect. This Change Order is executed by each of the Parties' duly authorized representatives.



**SCHEDULE D-1**

**CHANGE ORDER FORM**

**PROJECT NAME:** Sabine Pass LNG Receiving,  
Storage and Regasification Terminal

**CHANGE ORDER NUMBER:** SP/BE-027

**OWNER:** Sabine Pass LNG, L.P.

**DATE OF CHANGE ORDER:** January 20, 2006

**CONTRACTOR:** Bechtel Corporation

**INCREASE PLANT ELEVATIONS & ADD  
CONTROL BUILDING "SAFE ROOM"**

**DATE OF AGREEMENT:** December 18, 2004

\_\_\_\_\_  
/s/ Stan Horton  
\* Charif Souki  
Chairman

\_\_\_\_\_  
Contractor

\_\_\_\_\_  
Name

\_\_\_\_\_  
February 6, 2006  
Date of Signing

\_\_\_\_\_  
Title

\_\_\_\_\_  
Date of Signing

\_\_\_\_\_  
/s/ Stan Horton  
\*Stan Horton  
President & COO Cheniere Energy

\_\_\_\_\_  
February 6, 2006  
Date of Signing

\_\_\_\_\_  
/s/ Keith Meyer  
\*Keith Meyer  
President Cheniere LNG

\_\_\_\_\_  
January 31, 2006  
Date of Signing

\_\_\_\_\_  
/s/ Ed Lehotsky  
\*Ed Lehotsky  
Owner Representative

\_\_\_\_\_  
January 23, 2006  
Date of Signing

\* Required Owner signature - Mr. Horton may sign on behalf of Mr. Souki during Mr. Souki's absence.

**FORM OF CONSENT AND WAIVER AGREEMENT NO. 8  
TO CREDIT AGREEMENT**

This CONSENT AND WAIVER AGREEMENT NO. 8 TO CREDIT AGREEMENT (this "Consent"), dated as of November 28, 2005, is made among Sabine Pass LNG, L.P., a Delaware limited partnership (the "Borrower"), Société Générale, in its capacity as administrative agent for the Lenders (the "Agent"), HSBC Bank USA, National Association, in its capacity as collateral agent for the Lenders (the "Collateral Agent") and the Lenders party to the Credit Agreement (as defined below).

WITNESSETH

WHEREAS, the Borrower, the Agent and the Collateral Agent are party to a Credit Agreement dated as of February 25, 2005 (as amended, modified and supplemented and in effect from time to time, the "Credit Agreement"), pursuant to which the lenders from time to time party thereto (the "Lenders") have agreed to make loans to the Borrower in an aggregate principal amount of up to \$822,000,000;

WHEREAS, the Borrower and Bechtel Corporation (the "EPC Contractor") have entered into an Engineering, Procurement and Construction Agreement (as amended, modified and supplemented and in effect from time to time, the "EPC Contract") relating to the Project;

WHEREAS, pursuant to the Consent Agreement No. 7 dated as of August 29, 2005 ("Consent No. 7") among the Borrower, the Agent and the Collateral Agent, Majority Lender consent was granted for a Change Order with respect to an increase in the Project's send-out pressure (the "Send-Out Pressure Change Order") which Send-Out Pressure Change Order was expected to result in an increase in the price of the EPC Contract of not more than \$50 million (as more fully described in the Consent Request Letter).

WHEREAS, a condition subsequent to the effectiveness of Consent No. 7 was a contribution to the Construction Account in cash in an amount of the Send-Out Pressure Change Order to be used for the purposes of paying Project Costs prior to the Funding Date (the "Change Order Price").

WHEREAS, pursuant to a consent request letter (the "Consent Request Letter") attached hereto as Exhibit A, the Borrower has requested (a) a waiver and the consent of the Lenders pursuant to Section 8.16(e) of the Credit Agreement, for the incurrence of unsecured subordinated Indebtedness to be provided by an Affiliate of the Borrower in an amount not to exceed \$50 million, which Indebtedness shall be subordinated to the Secured Obligations on terms substantially in the form attached as Exhibit F to the Credit Agreement (the "Subordinated Indebtedness") and (b) a waiver of Section 8.20(a)(i)(C)(1) of the Credit Agreement and of Section 4(a) of Consent No. 7 in order to permit the Borrower to contribute the proceeds of such Subordinated Indebtedness to fund the Send-Out Pressure Change Order in lieu of an equity contribution.

Consent and Amendment No. 8

NOW THEREFORE, in consideration of the mutual agreements herein contained and other good and valuable consideration, the receipt and sufficiency of which are hereby acknowledged, the parties hereto, intending to be legally bound hereby, agree as follows:

Section 1. Definitions. Capitalized terms (including those used in the preamble and the recitals above) not otherwise defined herein shall have the meanings assigned to such terms in the Credit Agreement and the principles of interpretation set forth therein shall apply herein.

Section 2. Subordinated Indebtedness. Subject to the satisfaction of the condition set forth in Section 4 hereof, the Agent, acting with the consent of the Majority Lenders, hereby (a) consents to the incurrence of the Subordinated Indebtedness by the Borrower, provided that such Indebtedness is incurred on terms substantially in the form attached hereto as Exhibit B and (b) waives the requirements of the proviso to Section 8.16 of the Credit Agreement solely to the extent necessary for the Borrower to incur the Subordinated Indebtedness on the terms referred to in clause (a) above.

Section 3. Equity Contribution Requirements. Subject to the satisfaction of the condition set forth in Section 4 hereof, the Agent, acting with the consent of the Majority Lenders, hereby waives the requirements of Section 8.20(a)(i)(C)(1) of the Credit Agreement and Section 4(a) of Consent No. 7 to make a contribution in connection with the Send-Out Pressure Change Order, solely to the extent necessary to permit the Borrower to satisfy such contribution obligation by contributing the proceeds of the Subordinated Indebtedness to the Construction Account in lieu thereof.

Section 4. Condition Precedent. This Consent shall become effective on the date on which the Agent has received counterparts of this Consent duly executed and delivered by the Borrower.

Section 5. Miscellaneous.

(a) Limited Consent.

(i) Except as expressly consented to hereby, all of the representations, warranties, terms, covenants, conditions and other provisions of the Credit Agreement and the other Financing Documents shall remain unchanged and unwaived and shall continue to be and shall remain in full force and effect in accordance with their respective terms.

(ii) The consent set forth herein shall be limited precisely as provided for herein to the provisions expressly consented to and shall not be deemed to be a waiver of any right, power or remedy of any Lender, the Agent or the Collateral Agent under, or a waiver of, consent to or modification of, any other term or provision of the Credit Agreement, any other Financing Document referred to therein or herein or of any transaction or further or future action on the part of the Borrower which would require the consent of the Lenders under the Credit Agreement or any of the other Financing Documents.

Consent and Amendment No. 8

---

(iii) Except as provided in Section 2 and Section 3 hereof, nothing contained in this Consent shall abrogate, prejudice, diminish or otherwise affect any powers, rights, remedies or obligations of any Person arising before the date of this Consent.

(b) Financing Document. This Consent shall be deemed to be a Financing Document referred to in the Credit Agreement and shall be construed, administered and applied in accordance with the terms and provisions thereof.

(c) Counterparts; Integration; Effectiveness. This Consent may be executed in any number of counterparts, all of which taken together shall constitute one and the same instrument and any party hereto may execute this Consent by signing any such counterpart.

(d) Costs and Expenses. The Borrower agrees to pay and reimburse the Agent for all its reasonable costs and out-of-pocket expenses (including, without limitation, the reasonable fees and expenses of counsel to the Agent and the Lenders) incurred in connection with the preparation and delivery of this Consent and such other related documents.

(e) Governing Law. **THIS CONSENT AND THE RIGHTS AND OBLIGATIONS OF THE PARTIES HEREUNDER SHALL BE GOVERNED BY, AND CONSTRUED IN ACCORDANCE WITH, THE LAWS OF THE STATE OF NEW YORK.**

[Signature Pages Follow]

Consent and Amendment No. 8

---

IN WITNESS WHEREOF, the parties hereto have caused this Consent to be duly executed and delivered as of the day and year first above written.

SABINE PASS LNG, L.P.,  
as Borrower

By: Sabine Pass LNG – GP, Inc.,  
its General Partner

By: /s/ Graham McArthur  
Name: Graham McArthur  
Title: Treasurer

Address for Notices:  
717 Texas Avenue, Suite 3100  
Houston, TX 77002  
Attn: Treasurer

Consent and Amendment No. 8

---

SOCIÉTÉ GÉNÉRALE,  
as Agent

By: /s/ Edward J. Grimm  
Name: Edward J. Grimm  
Title: Director

Address for Notices:  
1221 Avenue of the Americas  
New York, NY 10020  
Attn: Robert Preminger

Consent and Amendment No. 8

---

HSBC BANK USA, NATIONAL ASSOCIATION,  
as Collateral Agent

By: /s/ Deirdra N. Ross

Name: Deirdra N. Ross

Title: Assistant Vice President

Address for Notices:

HSBC Bank USA, National Association  
452 Fifth Avenue  
New York, NY 10018  
Attn: Corporate Trust

With a copy to:

DLA Piper Rudnick Gray Cary US LLP  
One Liberty Place  
1650 Market Street, Suite 4900  
Philadelphia, PA 19103  
Attn: Peter Tucci, Esq.

Consent and Amendment No. 8

Consent Request Letter

Consent and Amendment No. 8





November 14, 2005

Societe Generale  
1221 Avenue of the Americas  
New York, NY 10020  
Attn: Edward Grimm

**Re: Credit Agreement dated February 25, 2005 (the "Credit Agreement") among Sabine Pass LNG, L.P. ("Sabine"), Societe Generale, as Agent, HSBC Bank USA, National Association, as Collateral Agent and the Lenders party thereto**

Dear Mr. Grimm:

Reference is made to the captioned Credit Agreement. Capitalized terms used but not defined herein shall have the meanings assigned to such terms in the Credit Agreement.

Pursuant to Section 8.16(e) of the Credit Agreement, Sabine hereby requests the consent of the Lenders to incur \$50 million of unsecured Indebtedness for borrowed money that will be subordinated to the Secured Obligations and in the form of Exhibit F to the Credit Agreement. For the avoidance of doubt, Sabine also requests the waiver of Section 8.20(a)(i)(C) as it is using the proceeds of the contemplated Indebtedness to fulfill its funding obligations permitted under Consent Agreement No. 7 dated August 29, 2005 ("August Consent").

Sabine intends to use this unsecured Indebtedness to fund its obligations pursuant to Section 4(a) of the August Consent, whereby the Majority Lenders provided their approval for Sabine to increase the send out pressure of the facility. This approval was given subject to the receipt of cash by the Collateral Agent of the amount of the send out pressure change order for deposit to the Construction Account.

Sabine intends to borrow this money from an affiliate company of its ultimate parent, Cheniere Energy, Inc. (Cheniere). The affiliate borrowing is being made to provide flexibility to both Sabine and Cheniere in terms of their liquidity and capital structures. The contemplated Indebtedness will be unsecured and subordinate to the interests of the Senior Lenders with a maturity date in 2015 and no scheduled debt amortization due until final maturity.

As stipulated in the August Consent, the proceeds associated with the contribution of funds related with the send out pressure will not constitute part of the Equity Contribution Amount. The Equity Contribution Amount together with the proceeds from the unsecured Indebtedness will be used to pay Project Costs prior to the Funding Date.

**SABINE PASS LNG, L.P.**  
**717 Texas Avenue, Suite 3100 – Houston, Texas 77002 – (713) 659-1361 – Fax (713) 659-5459**

---

Mr. Edward Grimm  
November 14, 2005  
Page 2

Through October 31, 2005, Sabine has received equity contributions totaling \$216.7 million of the required Equity Contribution Amount of \$233.7 million. The EPC invoice due November 28, 2005 is approximately \$30 million resulting in a funding requirement of \$13 million. Proceeds from the subordinated Indebtedness will be utilized for this requirement and for additional project costs up to the amount of the subordinated Indebtedness.

Based on current projections, Sabine anticipates the initial Funding Date to be December 23, 2005.

Sincerely,

SABINE PASS LNG, L.P.

By: /s/ Graham A. McArthur  
Graham A. McArthur  
Treasurer

Subordinated Note

(see attached)

SUBORDINATED PROMISSORY NOTE  
SABINE PASS LNG, L.P.

Houston, Texas  
November 28, 2005

**\$50,000,000**

SABINE PASS LNG, L.P. (the "Borrower"), a Delaware limited partnership, for value received, hereby promises to pay to CHENIERE LNG FINANCIAL SERVICES, INC., a Delaware corporation ("Cheniere") on June 30, 2015 (the "Maturity Date") the principal sum of the lesser of (a) **FIFTY MILLION and No/100 DOLLARS (\$50,000,000)** or (b) so much thereof as has been advanced from time to time by Cheniere. Interest shall accrue at the rate of the sum of the LIBO Rate (defined below) plus 3% per annum on the principal amount of this Note outstanding from time to time and shall be payable on the Maturity Date. The amount of interest payable shall be computed on the basis of a 360-day year and, for any period less than a full calendar month, the actual number of days elapsed in such month. In the event that the Maturity Date of this Note occurs on a day that is not a Business Day, then the payment payable on such date will be made on the next succeeding day that is a Business Day (and without any interest or other payment in respect of any such delay).

Payment of principal and interest shall be made to Cheniere in such coin or currency of the United States of America as at the time of payment shall be legal tender for the payment of public and private debts. All payments of principal and interest on this Note shall be made no later than 12:00 Noon (Houston time) on the Maturity Date via electronic wire transfer in immediately available funds to a bank account in the United States of America, as shall be directed by Cheniere to the Borrower. Subject to Section 5 hereof, the principal and interest on this Note may be prepaid at any time in whole or in part without any prepayment premium or make whole payment.

**SECTION 1 DEFINITIONS**

1.1 Capitalized terms that are defined herein shall have the meanings specified herein. Capitalized terms not otherwise defined herein shall have the meanings set forth in the Credit Agreement (including Exhibit F thereto) dated as of February 25, 2005, among the Borrower, each of the lenders party to the Credit Agreement, Société Générale, as agent for the Lenders (in such capacity, together with its successors in such capacity, the "Agent") and HSBC Bank USA, National Association as collateral agent for the secured parties specified therein (the "Credit Agreement").

**"Interest Period"** means the period commencing on the date hereof, and ending on the last day of the period selected by the Borrower pursuant to the provisions below and, thereafter, each subsequent period commencing on the last day of the immediately preceding Interest Period and ending on the last day of the period selected by the Borrower pursuant to the provisions below. The duration of each such Interest Period shall be one, two, three or six months, as the Borrower may, upon notice received by Cheniere not later than 11:00 a.m. (Houston time) on the third Business Day prior to the first day of such Interest Period, select; *provided, however*, that:

(a) whenever the last day of any Interest Period would otherwise occur on a day other than a Business Day, the last day of such Interest Period shall be extended to occur on the next succeeding Business Day; *provided, however*, that, if such extension would cause the last day of such Interest Period to occur in the next following calendar month, the last day of such Interest Period shall occur on the next preceding Business Day;

---

(b) whenever the first day of any Interest Period occurs on a day of an initial calendar month for which there is no numerically corresponding day in the calendar month that succeeds such initial calendar month by the number of months equal to the number of months in such Interest Period, such Interest Period shall end on the last Business Day of such succeeding calendar month; and

(c) if the Borrower shall fail to select the duration of any Interest Period as set forth above, the Borrower shall automatically be deemed to have selected an interest period of three months.

## SECTION 2 REPRESENTATIONS AND WARRANTIES

2.1 The Borrower represents and warrants to Cheniere that the representations and warranties contained in Article VII of the Credit Agreement are true and correct on the date hereof.

## SECTION 3 COVENANTS

3.1 The Borrower covenants and agrees with Cheniere that until the Maturity Date, it shall comply with the covenants of the Borrower as set forth in Sections 8.01, 8.02, 8.03, 8.04, 8.05(a), 8.06, 8.07, 8.08, 8.11, 8.12, 8.13, 8.14, 8.15, 8.16, 8.17, 8.18, 8.23, 8.24, 8.25, 8.30, 8.31 and 8.32 of the Credit Agreement.

## SECTION 4 EVENTS OF DEFAULT

4.1 Events of Default; Remedies. If one or more of the following events (each, an “Event of Default”) shall occur and be continuing:

(a) the Borrower shall default in the payment of any amounts due on this Note on the Maturity Date; or

(b) (i) any representation or warranty made by the Borrower in this Note shall prove to have been false or misleading in any material respect as of the time made, and such condition or circumstance could reasonably be expected to have a Material Adverse Effect; provided, that such misrepresentation or such false statement shall not constitute an Event of Default if such condition or circumstance is (A) subject to cure, as determined by Cheniere in its reasonable judgment and (B) remedied within 30 days after the earlier of (I) written notice of such default from Cheniere or (ii) the Borrower’s Knowledge of such default; or

---

(c) the Borrower shall fail to observe or perform any covenant or agreement contained in Section 8.02, 8.04(c), 8.11(a), 8.12, 8.13, 8.15(b), 8.16, 8.30 or 8.31 of the Credit Agreement which are incorporated into this Note in Section 3 above; or

(d) the Borrower shall default in the performance of any of its covenants or material agreements to be performed or observed by it under this Note (not otherwise addressed in this Section 4) and such default, if capable of remedy, shall continue unremedied for a period of 30 days after written notice of such default (specifying such default and requiring remedy thereof) from Cheniere; provided, that if such failure is not capable of remedy within such 30-day period, such 30-day period shall be extended to a total period of 60 days so long as (i) such default is subject to cure, (ii) the Borrower is diligently and continuously proceeding to cure such default and (iii) such additional cure period could not reasonably be expected to result in a Material Adverse Effect or materially and adversely affect the Borrower's rights, duties, obligations or liabilities under any TUA with an Anchor Tenant; or

(e) the occurrence of an Event of Default under the Credit Agreement.

then, subject to Section 5 below, Cheniere may at its option by notice to the Borrower declare all principal of and interest accrued on this Note to be, and such principal and interest shall automatically become, immediately due and payable.

#### **SECTION 5 SUBORDINATION**

5.1 Subordination to Secured Obligations. The Borrower covenants and agrees, and Cheniere covenants and agrees (on behalf of it and its successors and assigns) that payments of the principal of and interest on this Note and all other amounts payable hereunder are and shall be subordinate in right of payment to the indefeasible prior payment in full, in cash, of all existing and future Secured Obligations and that the subordination provided for in this Section 5 is for the benefit of Persons holding Secured Obligations from time to time and their representatives and shall remain subordinate as long as any Secured Obligations are outstanding or any commitment to advance any Secured Obligations exists.

5.2 Default on Secured Obligations. Upon any payment or distribution of assets or securities of the Borrower of any kind or character, whether in cash, securities or other property, to creditors of the Borrower in a liquidation (total or partial), reorganization, winding-up or dissolution of the Borrower, whether voluntary or involuntary, or in a bankruptcy, reorganization, insolvency, receivership, assignment for the benefit of creditors, marshaling of assets or similar proceeding relating to the Borrower or any of its property or credits:

(a) the holders of Secured Obligations shall be entitled to receive indefeasible payment in full, in cash, of such Secured Obligations before Cheniere shall be entitled to receive any payment of principal of or interest on, or any other payment or distribution of assets or securities (other than any interest or any securities the payment of which is subordinated at least to the same extent as this Note to the Secured Obligations, the rate of interest on which does not exceed the effective rate of interest on this Note and the principal of which, in whole or in part, is not due on or prior to the Final Maturity

---

Date) with respect to, this Note or on account of any purchase or other acquisition of any Subordinated Indebtedness by the Borrower; and

(b) until the Secured Obligations are indefeasibly paid in full in cash, any payment or distribution of assets or securities of the Borrower of any kind or character, whether in cash or other Property, to which Cheniere would be entitled but for this Section 5, shall be made by the Borrower or by any receiver, trustee in bankruptcy, liquidating trustee, agent or other Person making such payment of distribution directly to the holders of Secured Obligations to the extent necessary to pay all such Secured Obligations in full in cash.

5.3 No Payment. Cheniere hereby agrees that: (a) unless and until the principal of, and interest and premium (if any) on, and all other amounts in respect of, the Secured Obligations then due shall have been paid indefeasibly in full and in cash, no payment on account of the principal of, or interest or premium (if any) on, or any other amount in respect of, this Note or any judgment with respect thereto (and no payment on account of the purchase or redemption or other acquisition of this Note) shall be made by or on behalf of the Borrower and (b) unless and until the principal of, and interest and premium (if any) on, and all other amounts in respect of, the Secured Obligations shall have been paid indefeasibly in full and in cash Cheniere shall not (i) ask, demand, sue for, take or receive from the Borrower, by set-off or in any other manner any payment on account of the principal of, or interest or premium (if any) on, or any other amount in respect of, this Note or (ii) seek any other remedy allowed at law or in equity against the Borrower for breach of the Borrower's obligations under this Note. The provisions of this Section 5.3 shall not alter the rights of the holders of Secured Obligations under the provisions of Section 5.2 hereof.

5.4 Payments In Trust. If Cheniere shall at any time receive any payment or distribution that is not permitted under this Section 5, such payment or distribution shall be held by Cheniere in trust for the benefit of, and shall be promptly paid over and delivered to, in the form received but with any necessary endorsements, the Agent for the benefit of the holders of Secured Obligations (*pro rata* as to each of such holders on the basis of the respective amounts of Secured Obligations held by them), for application to the payment of all Secured Obligations remaining unpaid to the extent necessary to pay all Secured Obligations in full in cash in accordance with its terms, after giving effect to any concurrent payment or distribution to or for the holders of Secured Obligations.

5.5 Subrogation. After all Secured Obligations are indefeasibly paid in full in cash and all commitments to advance any Secured Obligations have been terminated, and until this Note is paid in full, Cheniere shall be subrogated (equally and ratably with the holders of all indebtedness of the Borrower that by its express terms is subordinated to Secured Obligations of the Borrower to the same extent as this Note is subordinated and that is entitled to like rights of subrogation) to the rights of the holders of Secured Obligations to receive distributions applicable to Secured Obligations to the extent that distributions otherwise payable to Cheniere have been applied to payment of Secured Obligations.

5.6 No Impairment.

(a) Nothing in this Section 5 shall (i) impair, as between the Borrower and Cheniere, the obligation of the Borrower to pay principal of and interest on this Note in accordance with its terms, (ii) affect the relative rights of Cheniere and the creditors of the Borrower other than the holders of Secured Obligations, (iii) if applicable, prevent Cheniere from exercising remedies upon the occurrence of an Event of Default as provided above, subject to the rights of holders of Secured Obligations under this Section 5 or (iv) create or imply the existence of any commitment on the part of the holders of Secured Obligations to extend credit to the Borrower.

(b) No right of any present or future holder of Secured Obligations to enforce the subordination provisions of this Section 5 shall at any time in any way be prejudiced or be impaired by any act or failure to act by the Borrower or anyone in custody of its assets or property or by its failure to comply with the Credit Agreement or this Note. Without in any way limiting the generality of the foregoing, the holders of the Secured Obligations may, at any time and from time to time, without the consent of or notice to Cheniere, without incurring any responsibility to Cheniere and without impairing, limiting or releasing the subordination provided in this Section 5 or the obligations under this Section 5 of Cheniere to the holders of the Secured Obligations to do any one or more of the following: (i) change the manner, place or terms of payment or extend the time of payment of, or renew or alter, Secured Obligations or any instrument evidencing the same or any agreement under which Secured Obligations are outstanding; (ii) sell, exchange, release or otherwise deal with any property pledged, mortgaged or otherwise securing Secured Obligations; (iii) release any Person guaranteeing or otherwise liable for Secured Obligations; and (iv) exercise or refrain from exercising any rights against the Borrower, any other Person or any collateral securing any Secured Obligations.

5.7 Reliance by Holders of Secured Obligations on Subordination Provisions. Cheniere as beneficiary of this Note acknowledges and agrees that the provisions of this Section 5 are, and are intended to be, an inducement and a consideration to each holder of any Secured Obligations, whether such Secured Obligations were created or acquired before or after the issuance or incurrence of the Subordinated Indebtedness evidenced by this Note, to acquire and continue to hold, or to continue to hold, such Secured Obligations and such holder of Secured Obligations shall be deemed conclusively to have relied on such subordination provisions in acquiring and continuing to hold, or in continuing to hold, such Secured Obligations. The provisions of this Section 5 may not be amended, altered or modified without the consent of the holders of such Secured Obligations.

5.8 Agent to Effectuate Subordination. Cheniere hereby appoints the Agent as its attorney-in-fact to take such actions as may be necessary to effectuate the subordination provided for in this Section 5, including in any proceeding referred to in Section 5.2. If Cheniere does not file any proof or claim of debt in any such proceeding within 30 days prior to the last date for the filing of any such proof or claim of debt, then, so long as any Secured Obligations shall be outstanding, the Agent shall be entitled, and is hereby authorized, to file any appropriate proof or claim on behalf of Cheniere.



5.9 No Waiver of Provisions. No right of the Agent or any holder of any Secured Obligations to enforce this Section 5 shall in any way be impaired by any act or failure to act on the part of the Borrower or on the part of the Agent or any such holder or by any noncompliance by the Borrower with the terms of any agreement or instrument evidencing this Note, the Credit Agreement or any Financing Document, whether or not the Agent or any such holder has knowledge of such noncompliance. Without limiting the generality of the foregoing, the Agent and such holders may, without notice to or consent from Cheniere and without impairing the right of the Agent or any such holder to enforce this Section 5, do any of the following:

- (a) amend, modify, supplement, renew, replace, or extend the terms of all or any part of the Secured Obligations or the Credit Agreement or any other Financing Document in any respect whatsoever;
- (b) sell or otherwise transfer, release, realize upon or enforce or otherwise deal with, all or any part of the Secured Obligations or the Credit Agreement or any other Financing Document or any collateral securing or guaranty supporting all or any part of the Secured Obligations;
- (c) settle or compromise all or any part of the Secured Obligations or any other liability of the Borrower to the Agent or any such holder and apply any sums received to the Secured Obligations or any such liability in such manner and order as the Agent or any such holder may determine; and
- (d) fail to take or to perfect, for any reason or for no reason, any Lien securing all or any part of the Secured Obligations, exercise or delay in or refrain from exercising any remedy against the Borrower or any security or guarantor for all or any part of the Secured Obligations, or make any election of remedies or otherwise deal freely with respect to all or any part of the Secured Obligations or any security or guaranty for all or any part of the Secured Obligations.

#### SECTION 6 MISCELLANEOUS

6.1 Giving of Notice. Any notice, request, complaint, demand, communication, or other paper shall be sufficiently given and shall be deemed given when delivered by hand or on the fifth (5th) day after being mailed by registered or certified first class mail, postage prepaid, addressed as follows:

To the Borrower:

Sabine Pass LNG, L.P.  
c/o Sabine Pass LNG-G.P., Inc  
717 Texas Avenue , Suite 3100  
Houston, Texas 77002  
Attn: Treasurer  
Telephone No.: (832) 204 2290  
Telecopier No.: (713) 659 5459

---

To Cheniere:                   Cheniere LNG Financial Services, Inc.  
717 Texas Avenue, Suite 3100  
Houston, Texas 77002  
Attn: Chief Financial Officer  
Telephone No.: (713) 265 0220  
Telecopier No.: (713) 659 5459

The above parties may, by notice given hereunder, designate any further or different addresses to which subsequent notices, certificates or other communications shall be sent.

**6.2 Special Exculpation. TO THE EXTENT PERMITTED BY APPLICABLE GOVERNMENT RULE, NO CLAIM MAY BE MADE BY ANY PARTY HERETO AGAINST ANY OTHER PARTY HERETO OR ANY OF THEIR RESPECTIVE AFFILIATES, DIRECTORS, OFFICERS, EMPLOYEES, ATTORNEYS OR AGENTS FOR ANY SPECIAL, INDIRECT, CONSEQUENTIAL OR PUNITIVE DAMAGES IN RESPECT OF ANY CLAIM FOR BREACH OF CONTRACT OR ANY OTHER THEORY OF LIABILITY ARISING OUT OF OR RELATING TO, OR ANY ACT, OMISSION OR EVENT OCCURRING IN CONNECTION WITH THIS NOTE OR THE TRANSACTION CONTEMPLATED BY THIS NOTE (OTHER THAN THE RIGHTS OF CHENIERE EXPRESSLY SET FORTH IN THIS NOTE), AND EACH PARTY HEREBY WAIVES, RELEASES AND AGREES NOT TO SUE UPON ANY CLAIM FOR ANY SUCH DAMAGES, WHETHER OR NOT ACCRUED AND WHETHER OR NOT KNOWN OR SUSPECTED TO EXIST IN ITS FAVOR.**

**6.3 Expenses, Etc.** The Borrower agrees to pay or reimburse Cheniere for: (a) all reasonable out-of-pocket costs and expenses of Cheniere (including the reasonable fees and expenses of counsel to Cheniere from time to time, in connection with (i) the negotiation, preparation, execution and delivery of this Note and (ii) any amendment, modification or waiver of any of the terms of this Note, and (b) all reasonable costs and expenses of (including reasonable counsels' fees and expenses) in connection with (i) any Event of Default and any enforcement or collection proceedings resulting from such Event of Default or in connection with the negotiation of any restructuring or "work-out" (whether or not consummated) of the obligations of the Borrower under this Note and (ii) the enforcement of this **Section 6.3(b)** and all transfer, stamp, documentary or other similar taxes, assessments or charges levied by any Government Authority in respect of this Note or any other document referred to in this Note.

The Borrower hereby agrees to indemnify Cheniere and its respective officers, directors, employees, representatives, attorneys and agents (each, an **Indemnitee**) from, and shall hold each of them harmless against, any and all losses, liabilities, claims, damages, expenses, obligations, penalties, actions, judgments, suits, costs or disbursements of any kind or nature whatsoever (including the reasonable fees and expenses of counsel for each Indemnitee in connection with any investigative, administrative or judicial proceeding commenced or threatened, whether or not such Indemnitee shall be designated a party to any such proceeding) that may at any time (including at any time following the Maturity Date) be imposed on, asserted against or incurred by an Indemnitee as a result of, or arising out of, or in any way related to or by reason of any claim of third parties with respect to (a) any of the transactions contemplated by

this Note or the execution, delivery or performance of this Note, and (b) the extensions of credit under this Note. Without limiting the generality of the foregoing, the Borrower hereby agrees to indemnify each Indemnitee from, and shall hold each Indemnitee harmless against, any losses, liabilities, claims, damages, reasonable expenses, obligations, penalties, actions, judgments, suits, costs or disbursements described in the preceding sentence (including any Lien filed against the Project by any Government Authority but excluding, as provided in the preceding sentence, any such losses, liabilities, claims, damages, expenses, obligations, penalties, actions, judgments, suits, costs or disbursements incurred directly and primarily by reason of the gross negligence or willful misconduct of such Indemnitee as finally determined by a court of competent jurisdiction) (collectively, "Losses") arising under any Environmental Law including any Environmental Claims or other Losses arising as a result of the past, present or future operations of the Borrower, or the past, present or future condition of the Project, or any Release or Use or threatened Release of any Hazardous Materials with respect to the Project (including any such Release or Use or threatened Release which shall occur during any period when such Indemnitee shall be in possession of any such site or facility following the exercise by Cheniere of any of its rights and remedies under this Note where such Use or Release commenced or occurred prior to such period); provided, however, that the Borrower shall have no such obligation to indemnify any Indemnitee to the extent that any such Release or Use is caused by such Indemnitee's gross negligence or willful misconduct as determined by a final non-appealable judgment.

6.4 Waivers, Etc. The Borrower waives notice (including but not limited to notice of intent to accelerate and notice of acceleration, notice of protest and notice of dishonor), demand, presentment for payment, protest, diligence in collecting and the filing of suit for the purpose of fixing liability.

6.5 Captions. The captions and section headings appearing in this Note are included solely for convenience of reference and are not intended to affect the interpretation of any provision of this Note.

6.6 Integration. This Note constitutes the entire agreement and understanding between the parties to this Note with respect to the matters covered by this Note and supersedes any and all prior agreements and understandings, written or oral, with respect to such matters.

6.7 Severability. Any provision of this Note held to be invalid, illegal or unenforceable in any jurisdiction shall, as to such jurisdiction, be ineffective to the extent of such invalidity, illegality or unenforceability without affecting the validity, legality and enforceability of the remaining provisions of this Note and the invalidity of a particular provision in a particular jurisdiction shall not invalidate such provision in any other jurisdiction.

6.8 Limitation of Liability. Notwithstanding any other provision of this Note, there shall be no recourse against any Affiliates of the Borrower or any of their respective stockholders, partners, members, officers, directors, employees or agents (collectively, the "Nonrecourse Persons"), for any liability to Cheniere arising under this Note and Cheniere shall look solely to the Borrower in exercising its rights and remedies in connection therewith. The limitations on recourse set forth in this Section 6.8 shall survive the termination of this Note and the full and indefeasible payment this Note.

---

6.9 No Assignment. Except as otherwise permitted in the Credit Agreement, the Borrower shall not assign its rights or obligations under this Note without the prior consent of the Agent which consent shall not be unreasonably withheld.

6.10 Amendments, Etc. Any provision of this Note may be amended or modified only by an instrument in writing signed by the Borrower and Cheniere.

6.11 Governing Law; Submission to Jurisdiction. **THIS NOTE SHALL BE GOVERNED BY, AND CONSTRUED IN ACCORDANCE WITH, THE LAW OF THE STATE OF NEW YORK APPLICABLE TO CONTRACTS MADE AND TO BE PERFORMED IN SUCH STATE. THE PARTIES HEREBY SUBMIT TO THE NONEXCLUSIVE JURISDICTION OF THE UNITED STATES DISTRICT COURTS AND STATE COURTS SITTING IN NEW YORK CITY FOR THE PURPOSES OF ALL LEGAL PROCEEDINGS ARISING OUT OF OR RELATING TO THIS AGREEMENT OR THE TRANSACTIONS CONTEMPLATED BY THIS AGREEMENT AND THE OTHER FINANCING DOCUMENTS. EACH OF THE PARTIES HERETO IRREVOCABLY WAIVES, TO THE FULLEST EXTENT PERMITTED BY LAW, ANY OBJECTION WHICH IT MAY NOW OR HEREAFTER HAVE TO THE LAYING OF THE VENUE OF ANY SUCH PROCEEDING BROUGHT IN SUCH A COURT AND ANY CLAIM THAT ANY SUCH PROCEEDING BROUGHT IN SUCH A COURT HAS BEEN BROUGHT IN AN INCONVENIENT FORUM. THE BORROWER HEREBY APPOINTS AND DESIGNATES CT CORPORATION SYSTEM, WHOSE ADDRESS IS 111 EIGHTH AVENUE, 13<sup>TH</sup> FLOOR, NEW YORK, NY 10011, OR ANY OTHER PERSON HAVING AND MAINTAINING A PLACE OF BUSINESS IN THE STATE OF NEW YORK WHOM BORROWER MAY FROM TIME TO TIME HEREAFTER DESIGNATE (HAVING GIVEN 30 DAYS' NOTICE THEREOF TO THE COLLATERAL AGENT AND EACH HOLDER OF A NOTE THEN OUTSTANDING), AS THE DULY AUTHORIZED AGENT FOR RECEIPT OF SERVICE OF LEGAL PROCESS. NOTHING HEREIN SHALL AFFECT THE RIGHT OF THE PARTIES TO BRING PROCEEDINGS IN THE COURTS OF ANY OTHER JURISDICTION OR TO SERVE PROCESS IN ANY MANNER PERMITTED BY LAW.**

6.12 Waiver of Jury Trial. **THE BORROWER AND CHENIERE HEREBY IRREVOCABLY WAIVE, TO THE FULLEST EXTENT PERMITTED BY LAW, ANY AND ALL RIGHT TO TRIAL BY JURY IN ANY LEGAL PROCEEDING DIRECTLY OR INDIRECTLY ARISING OUT OF OR RELATING TO THIS NOTE OR THE TRANSACTION CONTEMPLATED BY THIS NOTE.**

IN WITNESS WHEREOF, this Note has been executed on behalf of the Borrower.

---

SABINE PASS LNG, L.P.  
"BORROWER"

By: /s/ Graham McArthur  
Name: Graham McArthur  
Title: Treasurer

Accepted as of the date first above written

CHENIERE LNG FINANCIAL SERVICES, INC.  
"CHENIERE"

By: /s/ Don A. Turkleson  
Name: Don A. Turkleson  
Title: Chairman, President, CEO & CFO

**FORM OF WAIVER AGREEMENT NO. 9  
TO CREDIT AGREEMENT**

This WAIVER AGREEMENT NO. 9 TO CREDIT AGREEMENT (this "Waiver"), dated as of January 23, 2006, is made among Sabine Pass LNG, L.P., a Delaware limited partnership (the "Borrower"), Société Générale, in its capacity as administrative agent for the Lenders (the "Agent"), HSBC Bank USA, National Association, in its capacity as collateral agent for the Lenders (the "Collateral Agent") and the Lenders party to the Credit Agreement (as defined below).

WITNESSETH

WHEREAS, the Borrower, the Agent and the Collateral Agent are party to a Credit Agreement dated as of February 25, 2005 (as amended, modified and supplemented and in effect from time to time, the "Credit Agreement"), pursuant to which the lenders from time to time party thereto (the "Lenders") have agreed to make loans to the Borrower in an aggregate principal amount of up to \$822,000,000;

WHEREAS, the Borrower and Chevron U.S.A. Inc. ("Chevron U.S.A.") have entered into a Terminal Use Agreement (as amended, modified and supplemented and in effect from time to time, the "Chevron TUA") setting forth the terms of the purchase and provision of terminalling services between the Borrower and Chevron U.S.A.;

WHEREAS, ChevronTexaco Corporation ("ChevronTexaco") has executed in favor of the Borrower a Guarantee dated December 15, 2004, setting forth the terms of the unconditional and irrevocable guaranty by ChevronTexaco of the payment obligations of the Chevron U.S.A. pursuant to the Chevron TUA;

WHEREAS, as a condition precedent to the Funding Date, the Borrower is required to provide to the Agent, a certificate of an Authorized Officer of ChevronTexaco and the Chevron U.S.A. (the "Certificates") certifying that the Guarantee and the Chevron TUA, respectively, are in full force and effect;

WHEREAS, pursuant to a waiver request letter (the "Waiver Request Letter") attached hereto as Exhibit A, the Borrower has requested a waiver of the requirements of Section 6.02(i)(i) and (ii) of the Credit Agreement to deliver the Certificates in order to meet the conditions precedent to the Funding Date.

NOW THEREFORE, in consideration of the mutual agreements herein contained and other good and valuable consideration, the receipt and sufficiency of which are hereby acknowledged, the parties hereto, intending to be legally bound hereby, agree as follows:

Section 1. Definitions. Capitalized terms (including those used in the preamble and the recitals above) not otherwise defined herein shall have the meanings assigned

Waiver No. 9

---

to such terms in the Credit Agreement and the principles of interpretation set forth therein shall apply herein.

Section 2. Waiver. Subject to the satisfaction of the condition set forth in Section 3 hereof, the Agent, acting with the consent of each Lender, hereby waives compliance with the requirements of Section 6.02(i)(i) and (ii) of the Credit Agreement to deliver the Certificates as a condition precedent to the Funding Date.

Section 3. Condition Precedent. This Waiver shall become effective on the date on which the Agent has received counterparts of this Waiver duly executed and delivered by the Borrower.

Section 4. Miscellaneous.

(a) Limited Waiver.

(i) Except as expressly consented to hereby, all of the representations, warranties, terms, covenants, conditions and other provisions of the Credit Agreement and the other Financing Documents shall remain unchanged and unwaived and shall continue to be and shall remain in full force and effect in accordance with their respective terms.

(ii) The waiver set forth herein shall be limited precisely as provided for herein to the provisions expressly waived and shall not be deemed to be a waiver of any right, power or remedy of any Lender, the Agent or the Collateral Agent under, or a waiver of, consent to or modification of, any other term or provision of the Credit Agreement, any other Financing Document referred to therein or herein or of any transaction or further or future action on the part of the Borrower which would require the consent of the Lenders under the Credit Agreement or any of the other Financing Documents.

(iii) Except as provided in Section 2 hereof, nothing contained in this Waiver shall abrogate, prejudice, diminish or otherwise affect any powers, rights, remedies or obligations of any Person arising before the date of this Waiver.

(b) Financing Document. This Waiver shall be deemed to be a Financing Document referred to in the Credit Agreement and shall be construed, administered and applied in accordance with the terms and provisions thereof.

(c) Counterparts; Integration; Effectiveness. This Waiver may be executed in any number of counterparts, all of which taken together shall constitute one and the same instrument and any party hereto may execute this Waiver by signing any such counterpart.

(d) Costs and Expenses. The Borrower agrees to pay and reimburse the Agent for all its reasonable costs and out-of-pocket expenses (including, without limitation, the reasonable fees and expenses of counsel to the Agent and the Lenders) incurred in connection with the preparation and delivery of this Waiver and such other related documents.

Waiver No. 9

---

(c) Governing Law. THIS WAIVER AND THE RIGHTS AND OBLIGATIONS OF THE PARTIES HEREUNDER SHALL BE GOVERNED BY, AND CONSTRUED IN ACCORDANCE WITH, THE LAWS OF THE STATE OF NEW YORK.

[Signature Pages Follow]

Waiver No. 9

- 3 -



---

IN WITNESS WHEREOF, the parties hereto have caused this Waiver to be duly executed and delivered as of the day and year first above written.

SABINE PASS LNG, L.P.,  
as Borrower

By: Sabine Pass LNG – GP, Inc.,  
its General Partner

By: /s/ Graham A. McArthur  
Name: Graham A. McArthur  
Title: Treasurer

Address for Notices:

717 Texas Avenue, Suite 3100  
Houston, TX 77002  
Attn: Treasurer

Waiver No. 9

---

SOCIÉTÉ GÉNÉRALE,  
as Agent

By: /s/ Edward J. Grimm  
Name: Edward J. Grimm  
Title: Director

Address for Notices:  
1221 Avenue of the Americas  
New York, NY 10020  
Attn: Robert Preminger

Waiver No. 9

---

HSBC BANK USA, NATIONAL ASSOCIATION,  
as Collateral Agent

By: /s/ Deirdra N. Ross

Name: Deirdra N. Ross

Title: Assistant Vice President

Address for Notices:

HSBC Bank USA, National Association  
452 Fifth Avenue  
New York, NY 10018  
Attn: Corporate Trust

With a copy to:

DLA Piper Rudnick Gray Cary US LLP  
One Liberty Place  
1650 Market Street, Suite 4900  
Philadelphia, PA 19103  
Attn: Peter Tucci, Esq.

Waiver No. 9

Consent Request Letter

Waiver No. 9



January 5, 2006

Societe Generale  
1221 Avenue of the Americas  
New York, NY 10020  
Attn: Edward Grimm

**Re: Credit Agreement dated February 25, 2005 (the "Credit Agreement") among Sabine Pass LNG, L.P. ("Sabine"), Societe Generale, as Agent, HSBC Bank USA, National Association, as Collateral Agent and the Lenders party thereto**

Dear Mr. Grimm:

Reference is made to the captioned Credit Agreement. Capitalized terms used but not defined herein shall have the meanings assigned to such terms in the Credit Agreement.

Pursuant to Section 6.02 of the Credit Agreement, Sabine hereby requests the consent of each Lender to waive the requirement that Chevron U.S.A deliver an Anchor Tenant Certificate as required under Section 6.02(i) of the Credit Agreement.

Chevron U.S.A. has no contractual obligation under the Chevron TUA to deliver an Anchor Tenant Certificate. Chevron U.S.A. has informed the Borrower that its corporate practice is to only delivery certifications that it is contractually obligated to do so.

Sincerely,

SABINE PASS LNG, L.P.

By: /s/ Graham A. McArthur  
Graham A. McArthur  
Treasurer

**SABINE PASS LNG, L.P.**  
**717 Texas Avenue, Suite 3100 – Houston, Texas 77002 – (713) 659-1361 – Fax (713) 659-5459**

**CONSENT AND AMENDMENT NO. 10  
TO CREDIT AGREEMENT**

This CONSENT AND AMENDMENT NO. 10 TO CREDIT AGREEMENT (this "Amendment"), dated as of February \_\_, 2006, is made among Sabine Pass LNG, L.P., a Delaware limited partnership (the "Borrower"), Société Générale, in its capacity as administrative agent for the Lenders (the "Agent"), HSBC Bank USA, National Association, in its capacity as collateral agent for the Lenders (the "Collateral Agent") and the Lenders party to the Credit Agreement (as defined below).

WITNESSETH

WHEREAS, the Borrower, the Agent and the Collateral Agent are party to a Credit Agreement dated as of February 25, 2005 (as amended, modified and supplemented and in effect from time to time, the "Credit Agreement"), pursuant to which the lenders from time to time party thereto (the "Lenders") have agreed to make loans to the Borrower in an aggregate principal amount of \$822,000,000;

WHEREAS, as more fully described in the amendment request letter (the "Amendment Request Letter") attached hereto as Exhibit A, the Borrower wishes to amend (a) the terms of Section 1.01 of the Credit Agreement in order to modify the definition of "Guaranteed Substantial Completion Date" therein and (b) the terms of Section 6.03(d) of the Credit Agreement to enable the Borrower, solely for the purposes of the proposed February 2006 borrowing, to deliver a Borrowing Certificate concurrently with the Notice of Borrowing.

NOW THEREFORE, in consideration of the mutual agreements herein contained and other good and valuable consideration, the receipt and sufficiency of which are hereby acknowledged, the parties hereto, intending to be legally bound hereby, agree as follows:

Section 1. Definitions. Capitalized terms (including those used in the preamble and the recitals above) not otherwise defined herein shall have the meanings assigned to such terms in the Credit Agreement and the principles of interpretation set forth therein shall apply herein.

Section 2. Amendments. Subject to the satisfaction of the condition precedent set forth in Section 3 hereof, the Credit Agreement is hereby amended as follows:

(a) Section 1.01 of the Credit Agreement is amended by deleting the definition of "Guaranteed Substantial Completion Date" therein and replacing such definition in its entirety as follows:

"Guaranteed Substantial Completion Date" shall have the meaning assigned to such term in the EPC Contract (a) without giving effect to any Change Order that affects such date, except any such Change Order which has been approved by the Agent and the Majority Lenders or (b) after giving effect to an agreement in principle between the

---

Borrower and the EPC Contractor to extend the Guaranteed Substantial Completion Date as a result of a force majeure event (as defined in the EPC Contract), but only until such time as a Change Order with respect to such agreed extension has been approved or rejected by the Majority Lenders pursuant to Section 8.20; provided, that such Change Order is presented to the Lenders for approval within three months of the Borrower's receipt from the EPC Contractor of a written request for such extension.

(b) Section 6.03(d) of the Credit Agreement is amended by inserting the following language after "prior to" in the second line thereto:

"(or, in the case of the February 2006 borrowing, concurrently with)".

Section 3. Condition Precedent. This Amendment shall become effective on the date on which the Agent has received counterparts of this Amendment duly executed and delivered by the Borrower and the Majority Lenders.

Section 4. Miscellaneous.

(a) Limited Amendment.

(i) Except as expressly consented to or amended hereby, all of the representations, warranties, terms, covenants, conditions and other provisions of the Credit Agreement and the other Financing Documents shall remain unchanged and unwaived and shall continue to be and shall remain in full force and effect in accordance with their respective terms.

(ii) The consent and amendment set forth herein shall be limited precisely as provided for herein to the provisions expressly consented to or amended and shall not be deemed to be a waiver of any right, power or remedy of any Lender, the Agent or the Collateral Agent under, or a waiver of, consent to or modification of any other term or provision of the Credit Agreement, any other Financing Document referred to therein or herein or of any transaction or further or future action on the part of the Borrower which would require the consent of the Lenders under the Credit Agreement or any of the other Financing Documents.

(iii) Except as provided in Section 2 hereof, nothing contained in this Amendment shall abrogate, prejudice, diminish or otherwise affect any powers, rights, remedies or obligations of any Person arising before the date of this Amendment.

(b) Financing Document. This Amendment shall be deemed to be a Financing Document referred to in the Credit Agreement and shall be construed, administered and applied in accordance with the terms and provisions thereof.

(c) Counterparts; Integration; Effectiveness. This Amendment may be executed in any number of counterparts, all of which taken together shall constitute one and the same instrument and any parties hereto may execute this Amendment by signing any such counterpart.

Consent and Amendment No. 10

---

(d) Costs and Expenses. The Borrower agrees to pay and reimburse the Agent for all its reasonable costs and out-of-pocket expenses (including, without limitation, the reasonable fees and expenses of counsel to the Agent and the Lenders) incurred in connection with the preparation and delivery of this Amendment and such other related documents.

(e) Governing Law. **THIS AMENDMENT AND THE RIGHTS AND OBLIGATIONS OF THE PARTIES HEREUNDER SHALL BE GOVERNED BY, AND CONSTRUED IN ACCORDANCE WITH, THE LAWS OF THE STATE OF NEW YORK.**

[Signature Pages Follow]

Consent and Amendment No. 10



---

IN WITNESS WHEREOF, the parties hereto have caused this Amendment to be duly executed and delivered as of the day and year first above written.

SABINE PASS LNG, L.P.,  
as Borrower

By: Sabine Pass LNG – GP, Inc.,  
its General Partner

By: /s/ Graham McArthur  
Name: Graham McArthur  
Title: Treasurer

Address for Notices:  
717 Texas Avenue, Suite 3100  
Houston, TX 77002  
Attn: Treasurer

Consent and Amendment No. 10

---

SOCIÉTÉ GÉNÉRALE,  
as Agent

By: /s/ Edward J. Grimm  
Name: Edward J. Grimm  
Title: Director

Address for Notices:  
1221 Avenue of the Americas  
New York, NY 10020  
Attn: Robert Preminger

Consent and Amendment No. 10

---

HSBC BANK USA, NATIONAL ASSOCIATION, as Collateral  
Agent

By: /s/ Deirdra N. Ross

Name: Deirdra N. Ross

Title: Assistant Vice President

Address for Notices:

HSBC Bank USA, National Association  
452 Fifth Avenue  
New York, NY 10018  
Attn: Corporate Trust

With a copy to:

DLA Piper Rudnick Gray Cary US LLP  
One Liberty Place  
1650 Market Street, Suite 4900  
Philadelphia, PA 19103  
Attn: Peter Tucci, Esq.

Consent and Amendment No. 10

Amendment Request Letter

Consent and Amendment No. 10



February 10, 2006

Societe Generale  
1221 Avenue of the Americas  
New York, NY 10020  
Attn: Edward Grimm

**Re: Credit Agreement dated February 25, 2005 (as amended, modified or supplemented, the "Credit Agreement") among Sabine Pass LNG, L.P. ("Sabine"), Societe Generale, as Agent, HSBC Bank USA, National Association, as Collateral Agent and the Lenders party thereto**

Dear Mr. Grimm:

Reference is made to the captioned Credit Agreement. Capitalized terms used but not defined herein shall have the meanings assigned to such terms in the Credit Agreement.

Pursuant to Section 8.01(d) of the Credit Agreement, Sabine delivered to the Agent a notice dated, and delivered on February 8, 2006. The notice reflects that Sabine is in negotiation with the EPC Contractor regarding modifications to the contract price of the EPC Contract and an extension of the Guaranteed Substantial Completion Date in an effort to mitigate the force majeure effects of Hurricanes Katrina, Rita, and Wilma on the completion of the Project. These on-going negotiations are in accordance with Section 6.8 of the EPC Contract which detail the mechanism for dealing with time extensions and compensation which arise due to force majeure events.

In the on-going negotiations with the EPC Contractor, Sabine has tentatively agreed to increase the contract price of the EPC Contract in order for the Target Bonus Date of April 3, 2008 under the EPC Contract to be achieved. For this milestone to be accomplished, tanks one and two must be completed and have achieved a sendout rate of no less than 2,000 million standard cubic feet per day for a continuous period of at least 24 hours.

The costs associated with the mitigation of the effects of the hurricanes to achieve the Target Bonus Date are estimated to be between \$35 million to \$50 million. This estimate is comprised primarily of increased labor costs. Labor availability has been greatly affected by the amount of rebuilding that is going on in the region due to Hurricanes Katrina and Rita. To attract an adequate number of workers, the EPC Contractor is going to have to offer higher wages and higher per diems. In addition, due to the destruction of so much of the infrastructure in Cameron Parish, more workers will have to be provided with a per diem than originally planned.

Given the magnitude of the amounts involved, Sabine will have to obtain approval from its general partner's Board of Directors, as well as Lender consent pursuant to Section 8.20(a)(i) of the Credit Agreement. These expenditures are not currently reflected in the Construction Budget and Schedule. Sabine will not be looking to fund these expenditures through the Credit Agreement.

As part of the commercial negotiations with the EPC Contractor, Sabine has tentatively agreed to an extension of the Guaranteed Substantial Completion Date to December 20, 2008, which equates to an extension of 109 days from the current Guaranteed Substantial Completion Date of September 2, 2008. It should be noted that there is no contractual obligation for Sabine to provide services under either of its TUAs until April 1, 2009.

The extension of the Guaranteed Substantial Completion Date will be predicated upon the receipt and acceptance of a fully resource loaded level III schedule. In addition, Lender approval will be required pursuant to Section 8.20(a)(ii) of the Credit Agreement.

Given the anticipated (but not yet finalized) extension of the Guaranteed Substantial Completion Date to no later than December 20, 2008, and in order for Sabine to maintain an orderly sequence of monthly draws under the Credit Agreement for progress payments under the EPC Contract, it will be necessary to effect an amendment to Section 1.01 of the Credit Agreement definition of Guaranteed Substantial Completion Date to incorporate the effects of force majeure events into the defined term as Sabine will be unable to make the representation in the Borrowing Certificate pertaining to the project being able to be reasonably expected to achieve Substantial Completion by the Guaranteed Substantial Completion Date. In addition, it is also necessary to effect an amendment to Section 6.03(d) of the Credit Agreement to make the delivery of the February 2006 Borrowing Certificate to the Agent and the Independent Engineer be due no later than three business days prior to proposed February 24, 2006 borrowing date. Accordingly, please consider this as Sabine's request for the two amendments summarized above.

Sincerely,

SABINE PASS LNG, L.P.

By: /s/ Graham A. McArthur  
Graham A. McArthur  
Treasurer

**SABINE PASS LNG, L.P.**  
**717 Texas Avenue, Suite 3100 – Houston, Texas 77002 – (713) 659-1361 – Fax (713) 659-5459**

(Multicurrency — Cross Border)



**MASTER AGREEMENT**

dated as of **December 23, 2005**

**Credit Suisse First Boston International** and **Cheniere LNG Holdings, LLC** have entered and/or anticipate entering into one or more transactions (each a "Transaction") that are or will be governed by this Master Agreement, which includes the schedule (the "Schedule"), and the documents and other confirming evidence (each a "Confirmation") exchanged between the parties confirming those Transactions.

Accordingly, the parties agree as follows: —

**1. Interpretation**

- (a) **Definitions.** The terms defined in Section 14 and in the Schedule will have the meanings therein specified for the purpose of this Master Agreement.
- (b) **Inconsistency.** In the event of any inconsistency between the provisions of the Schedule and the other provisions of this Master Agreement, the Schedule will prevail. In the event of any inconsistency between the provisions of any Confirmation and this Master Agreement (including the Schedule), such Confirmation will prevail for the purpose of the relevant Transaction.
- (c) **Single Agreement.** All Transactions are entered into in reliance on the fact that this Master Agreement and all Confirmations form a single agreement between the parties (collectively referred to as this "Agreement"), and the parties would not otherwise enter into any Transactions.

**2. Obligations**

(a) **General Conditions.**

- (i) Each party will make each payment or delivery specified in each Confirmation to be made by it, subject to the other provisions of this Agreement.
- (ii) Payments under this Agreement will be made on the due date for value on that date in the place of the account specified in the relevant Confirmation or otherwise pursuant to this Agreement, in freely transferable funds and in the manner customary for payments in the required currency. Where settlement is by delivery (that is, other than by payment), such delivery will be made for receipt on the due date in the manner customary for the relevant obligation unless otherwise specified in the relevant Confirmation or elsewhere in this Agreement.
- (iii) Each obligation of each party under Section 2(a)(i) is subject to (1) the condition precedent that no Event of Default or Potential Event of Default with respect to the other party has occurred and is continuing, (2) the condition precedent that no Early Termination Date in respect of the relevant Transaction has occurred or been effectively designated and (3) each other applicable condition precedent specified in this Agreement.

Copyright © 1992 by International Swap Dealers Association, Inc.

(b) **Change of Account.** Either party may change its account for receiving a payment or delivery by giving notice to the other party at least five Local Business Days prior to the scheduled date for the payment or delivery to which such change applies unless such other party gives timely notice of a reasonable objection to such change.

(c) **Netting.** If on any date amounts would otherwise be payable:—

- (i) in the same currency; and
- (ii) in respect of the same Transaction,

by each party to the other, then, on such date, each party's obligation to make payment of any such amount will be automatically satisfied and discharged and, if the aggregate amount that would otherwise have been payable by one party exceeds the aggregate amount that would otherwise have been payable by the other party, replaced by an obligation upon the party by whom the larger aggregate amount would have been payable to pay to the other party the excess of the larger aggregate amount over the smaller aggregate amount.

The parties may elect in respect of two or more Transactions that a net amount will be determined in respect of all amounts payable on the same date in the same currency in respect of such Transactions, regardless of whether such amounts are payable in respect of the same Transaction. The election may be made in the Schedule or a Confirmation by specifying that subparagraph (ii) above will not apply to the Transactions identified as being subject to the election, together with the starting date (in which case subparagraph (ii) above will not, or will cease to, apply to such Transactions from such date). This election may be made separately for different groups of Transactions and will apply separately to each pairing of Offices through which the parties make and receive payments or deliveries.

(d) **Deduction or Withholding for Tax.**

(i) **Gross-Up.** All payments under this Agreement will be made without any deduction or withholding for or on account of any Tax unless such deduction or withholding is required by any applicable law, as modified by the practice of any relevant governmental revenue authority, then in effect. If a party is so required to deduct or withhold, then that party ("X") will:—

- (1) promptly notify the other party ("Y") of such requirement;
- (2) pay to the relevant authorities the full amount required to be deducted or withheld (including the full amount required to be deducted or withheld from any additional amount paid by X to Y under this Section 2(d)) promptly upon the earlier of determining that such deduction or withholding is required or receiving notice that such amount has been assessed against Y;
- (3) promptly forward to Y an official receipt (or a certified copy), or other documentation reasonably acceptable to Y, evidencing such payment to such authorities; and
- (4) if such Tax is an Indemnifiable Tax, pay to Y, in addition to the payment to which Y is otherwise entitled under this Agreement, such additional amount as is necessary to ensure that the net amount actually received by Y (free and clear of Indemnifiable Taxes, whether assessed against X or Y) will equal the full amount Y would have received had no such deduction or withholding been required. However, X will not be required to pay any additional amount to Y to the extent that it would not be required to be paid but for:—
  - (A) the failure by Y to comply with or perform any agreement contained in Section 4(a)(i), 4(a)(iii) or 4(d); or
  - (B) the failure of a representation made by Y pursuant to Section 3(f) to be accurate and true unless such failure would not have occurred but for (I) any action taken by a taxing authority, or brought in a court of competent jurisdiction, on or after the date on which a Transaction is entered into (regardless of whether such action is taken or brought with respect to a party to this Agreement) or (II) a Change in Tax Law.



(ii) **Liability of:**—

- (1) X is required by any applicable law, as modified by the practice of any relevant governmental revenue authority, to make any deduction or withholding in respect of which X would not be required to pay an additional amount to Y under Section 2(d)(i)(4);
- (2) X does not so deduct or withhold; and
- (3) a liability resulting from such Tax is assessed directly against X,

then, except to the extent Y has satisfied or then satisfies the liability resulting from such Tax, Y will promptly pay to X the amount of such liability (including any related liability for interest, but including any related liability for penalties only if Y has failed to comply with or perform any agreement contained in Section 4(a)(i), 4(a)(iii) or 4(d)).

(e) **Default Interest; Other Amounts.** Prior to the occurrence or effective designation of an Early Termination Date in respect of the relevant Transaction, a party that defaults in the performance of any payment obligation will, to the extent permitted by law and subject to Section 6(c), be required to pay interest (before as well as after judgment) on the overdue amount to the other party on demand in the same currency as such overdue amount, for the period from (and including) the original due date for payment to (but excluding) the date of actual payment, at the Default Rate. Such interest will be calculated on the basis of daily compounding and the actual number of days elapsed. If, prior to the occurrence or effective designation of an Early Termination Date in respect of the relevant Transaction, a party defaults in the performance of any obligation required to be settled by delivery, it will compensate the other party on demand if and to the extent provided for in the relevant Confirmation or elsewhere in this Agreement.

### 3. Representations

Each party represents to the other party (which representations will be deemed to be repeated by each party on each date on which a Transaction is entered into and, in the case of the representations in Section 3(f), at all times until the termination of this Agreement) that:—

(a) **Basic Representations.**

- (i) **Status.** It is duly organised and validly existing under the laws of the jurisdiction of its organisation or incorporation and, if relevant under such laws, in good standing;
- (ii) **Powers.** It has the power to execute this Agreement and any other documentation relating to this Agreement to which it is a party, to deliver this Agreement and any other documentation relating to this Agreement that it is required by this Agreement to deliver and to perform its obligations under this Agreement and any obligations it has under any Credit Support Document to which it is a party and has taken all necessary action to authorise such execution, delivery and performance;
- (iii) **No Violation or Conflict.** Such execution, delivery and performance do not violate or conflict with any law applicable to it, any provision of its constitutional documents, any order or judgment of any court or other agency of government applicable to it or any of its assets or any contractual restriction binding on or affecting it or any of its assets;
- (iv) **Consents.** All governmental and other consents that are required to have been obtained by it with respect to this Agreement or any Credit Support Document to which it is a party have been obtained and are in full force and effect and all conditions of any such consents have been complied with; and
- (v) **Obligations Binding.** Its obligations under this Agreement and any Credit Support Document to which it is a party constitute its legal, valid and binding obligations, enforceable in accordance with their respective terms (subject to applicable bankruptcy, reorganisation, insolvency, moratorium or similar laws affecting creditors' rights generally and subject, as to enforceability, to equitable principles of general application (regardless of whether enforcement is sought in a proceeding in equity or at law)).

(b) **Absence of Certain Events.** No Event of Default or Potential Event of Default or, to its knowledge, Termination Event with respect to it has occurred and is continuing and no such event or circumstance would occur as a result of its entering into or performing its obligations under this Agreement or any Credit Support Document to which it is a party.

(c) **Absence of Litigation.** There is not pending or, to its knowledge, threatened against it or any of its Affiliates any action, suit or proceeding at law or in equity or before any court, tribunal, governmental body, agency or official or any arbitrator that is likely to affect the legality, validity or enforceability against it of this Agreement or any Credit Support Document to which it is a party or its ability to perform its obligations under this Agreement or such Credit Support Document.

(d) **Accuracy of Specified Information.** All applicable information that is furnished in writing by or on behalf of it to the other party and is identified for the purpose of this Section 3(d) in the Schedule is, as of the date of the information, true, accurate and complete in every material respect.

(e) **Payer Tax Representation.** Each representation specified in the Schedule as being made by it for the purpose of this Section 3(e) is accurate and true.

(f) **Payee Tax Representations.** Each representation specified in the Schedule as being made by it for the purpose of this Section 3(f) is accurate and true.

#### 4. Agreements

Each party agrees with the other that, so long as either party has or may have any obligation under this Agreement or under any Credit Support Document to which it is a party:—

(a) **Furnish Specified Information.** It will deliver to the other party or, in certain cases under subparagraph (iii) below, to such government or taxing authority as the other party reasonably directs:—

(i) any forms, documents or certificates relating to taxation specified in the Schedule or any Confirmation;

(ii) any other documents specified in the Schedule or any Confirmation; and

(iii) upon reasonable demand by such other party, any form or document that may be required or reasonably requested in writing in order to allow such other party or its Credit Support Provider to make a payment under this Agreement or any applicable Credit Support Document without any deduction or withholding for or on account of any Tax or with such deduction or withholding at a reduced rate (so long as the completion, execution or submission of such form or document would not materially prejudice the legal or commercial position of the party in receipt of such demand), with any such form or document to be accurate and completed in a manner reasonably satisfactory to such other party and to be executed and to be delivered with any reasonably required certification,

in each case by the date specified in the Schedule or such Confirmation or, if none is specified, as soon as reasonably practicable.

(b) **Maintain Authorisations.** It will use all reasonable efforts to maintain in full force and effect all consents of any governmental or other authority that are required to be obtained by it with respect to this Agreement or any Credit Support Document to which it is a party and will use all reasonable efforts to obtain any that may become necessary in the future.

(c) **Comply with Laws.** It will comply in all material respects with all applicable laws and orders to which it may be subject if failure so to comply would materially impair its ability to perform its obligations under this Agreement or any Credit Support Document to which it is a party.

(d) **Tax Agreement.** It will give notice of any failure of a representation made by it under Section 3(f) to be accurate and true promptly upon learning of such failure.

(e) **Payment of Stamp Tax.** Subject to Section 11, it will pay any Stamp Tax levied or imposed upon it or in respect of its execution or performance of this Agreement by a jurisdiction in which it is incorporated,

organised, managed \_\_ controlled, or considered to have its seat, or in which a branch or office through which it is acting for the purpose of this Agreement is located (“Stamp Tax Jurisdiction”) and will indemnify the other party against any Stamp Tax levied or imposed upon the other party or in respect of the other party’s execution or performance of this Agreement by any such Stamp Tax Jurisdiction which is not also a Stamp Tax Jurisdiction with respect to the other party.

## 5. Events of Default and Termination Events

(a) **Events of Default.** The occurrence at any time with respect to a party or, if applicable, any Credit Support Provider of such party or any Specified Entity of such party of any of the following events constitutes an event of default (an “Event of Default”) with respect to such party:—

(i) **Failure to Pay or Deliver.** Failure by the party to make, when due, any payment under this Agreement or delivery under Section 2(a)(i) or 2(e) required to be made by it if such failure is not remedied on or before the third Local Business Day after notice of such failure is given to the party;

(ii) **Breach of Agreement.** Failure by the party to comply with or perform any agreement or obligation (other than an obligation to make any payment under this Agreement or delivery under Section 2(a)(i) or 2(e) or to give notice of a Termination Event or any agreement or obligation under Section 4(a)(i), 4(a)(iii) or 4(d)) to be complied with or performed by the party in accordance with this Agreement if such failure is not remedied on or before the thirtieth day after notice of such failure is given to the party;

(iii) **Credit Support Default.**

(1) Failure by the party or any Credit Support Provider of such party to comply with or perform any agreement or obligation to be complied with or performed by it in accordance with any Credit Support Document if such failure is continuing after any applicable grace period has elapsed;

(2) the expiration or termination of such Credit Support Document or the failing or ceasing of such Credit Support Document to be in full force and effect for the purpose of this Agreement (in either case other than in accordance with its terms) prior to the satisfaction of all obligations of such party under each Transaction to which such Credit Support Document relates without the written consent of the other party; or

(3) the party or such Credit Support Provider disaffirms, disclaims, repudiates or rejects, in whole or in part, or challenges the validity of, such Credit Support Document;

(iv) **Misrepresentation.** A representation (other than a representation under Section 3(e) or (f)) made or repeated or deemed to have been made or repeated by the party or any Credit Support Provider of such party in this Agreement or any Credit Support Document proves to have been incorrect or misleading in any material respect when made or repeated or deemed to have been made or repeated;

(v) **Default under Specified Transaction.** The party, any Credit Support Provider of such party or any applicable Specified Entity of such party (1) defaults under a Specified Transaction and, after giving effect, to any applicable notice requirement or grace period, there occurs a liquidation of, an acceleration of obligations under, or an early termination of, that Specified Transaction, (2) defaults, after giving effect to any applicable notice requirement or grace period, in making any payment or delivery due on the last payment, delivery or exchange date of, or any payment on early termination of, a Specified Transaction (or such default continues for at least three Local Business Days if there is no applicable notice requirement or grace period) or (3) disaffirms, disclaims, repudiates or rejects, in whole or in part, a Specified Transaction (or such action is taken by any person or entity appointed or empowered to operate it or act on its behalf);

(vi) **Cross Default.** If “Cross Default” is specified in the Schedule as applying to the party, the occurrence or existence of (1) a default, event of default or other similar condition or event (however

described) in respect of such party, any Credit Support Provider of such party or any applicable Specified Entity of such party under one or more agreements or instruments relating to Specified Indebtedness of any of them (individually or collectively) in an aggregate amount of not less than the applicable Threshold Amount (as specified in the Schedule) which has resulted in such Specified Indebtedness becoming, or becoming capable at such time of being declared, due and payable under such agreements or instruments, before it would otherwise have been due and payable or (2) a default by such party, such Credit Support Provider or such Specified Entity (individually or collectively) in making one or more payments on the due date thereof in an aggregate amount of not less than the applicable Threshold Amount under such agreements or instruments (after giving effect to any applicable notice requirement or grace period);

(vii) **Bankruptcy.** The party, any Credit Support Provider of such party or any applicable Specified Entity of such party: —

(1) is dissolved (other than pursuant to a consolidation, amalgamation or merger); (2) becomes insolvent or is unable to pay its debts or fails or admits in writing its inability generally to pay its debts as they become due; (3) makes a general assignment, arrangement or composition with or for the benefit of its creditors; (4) institutes or has instituted against it a proceeding seeking a judgment of insolvency or bankruptcy or any other relief under any bankruptcy or insolvency law or other similar law affecting creditors' rights, or a petition is presented for its winding-up or liquidation, and, in the case of any such proceeding or petition instituted or presented against it, such proceeding or petition (A) results in a judgment of insolvency or bankruptcy or the entry of an order for relief or the making of an order for its winding-up or liquidation or (B) is not dismissed, discharged, stayed or restrained in each case within 30 days of the institution or presentation thereof; (5) has a resolution passed for its winding-up, official management or liquidation (other than pursuant to a consolidation, amalgamation or merger); (6) seeks or becomes subject to the appointment of an administrator, provisional liquidator, conservator, receiver, trustee, custodian or other similar official for it or for all or substantially all its assets; (7) has a secured party take possession of all or substantially all its assets or has a distress, execution, attachment, sequestration or other legal process levied, enforced or sued on or against all or substantially all its assets and such secured party maintains possession, or any such process is not dismissed, discharged, stayed or restrained, in each case within 30 days thereafter; (8) causes or is subject to any event with respect to it which, under the applicable laws of any jurisdiction, has an analogous effect to any of the events specified in clauses (1) to (7) (inclusive); or (9) takes any action in furtherance of, or indicating its consent to, approval of, or acquiescence in, any of the foregoing acts; or

(viii) **Merger Without Assumption.** The party or any Credit Support Provider of such party consolidates or amalgamates with, or merges with or into, or transfers all or substantially all its assets to, another entity and, at the time of such consolidation, amalgamation, merger or transfer: —

(1) the resulting, surviving or transferee entity fails to assume all the obligations of such party or such Credit Support Provider under this Agreement or any Credit Support Document to which it or its predecessor was a party by operation of law or pursuant to an agreement reasonably satisfactory to the other party to this Agreement; or

(2) the benefits of any Credit Support Document fail to extend (without the consent of the other party) to the performance by such resulting, surviving or transferee entity of its obligations under this Agreement.

(b) **Termination Events.** The occurrence at any time with respect to a party or, if applicable, any Credit Support Provider of such party or any Specified Entity of such party of any event specified below constitutes an Illegality if the event is specified in (i) below, a Tax Event if the event is specified in (ii) below or a Tax Event Upon Merger if the event is specified in (iii) below, and, if specified to be applicable, a Credit Event

Upon Merger if the event is specified pursuant to (iv) below or an Additional Termination Event if the event is specified pursuant to (v) below:—

(i) **Illegality.** Due to the adoption of, or any change in, any applicable law after the date on which a Transaction is entered into, or due to the promulgation of, or any change in, the interpretation by any court, tribunal or regulatory authority with competent jurisdiction of any applicable law after such date, it becomes unlawful (other than as a result of a breach by the party of Section 4(b)) for such party (which will be the Affected Party): —

(1) to perform any absolute or contingent obligation to make a payment or delivery or to receive a payment or delivery in respect of such Transaction or to comply with any other material provision of this Agreement relating to such Transaction; or

(2) to perform, or for any Credit Support Provider of such party to perform, any contingent or other obligation which the party (or such Credit Support Provider) has under any Credit Support Document relating to such Transaction;

(ii) **Tax Event.** Due to (x) any action taken by a taxing authority, or brought in a court of competent jurisdiction, on or after the date on which a Transaction is entered into (regardless of whether such action is taken or brought with respect to a party to this Agreement) or (y) a Change in Tax Law, the party (which will be the Affected Party) will, or there is a substantial likelihood that it will, on the next succeeding Scheduled Payment Date (1) be required to pay to the other party an additional amount in respect of an Indemnifiable Tax under Section 2(d)(i)(4) (except in respect of interest under Section 2(e), 6(d)(ii) or 6(e)) or (2) receive a payment from which an amount is required to be deducted or withheld for or on account of a Tax (except in respect of interest under Section 2(e), 6(d)(ii) or 6(e)) and no additional amount is required to be paid in respect of such Tax under Section 2(d)(i)(4) (other than by reason of Section 2(d)(i)(4)(A) or (B));

(iii) **Tax Event Upon Merger.** The party (the “Burdened Party”) on the next succeeding Scheduled Payment Date will either (1) be required to pay an additional amount in respect of an Indemnifiable Tax under Section 2(d)(i)(4) (except in respect of interest under Section 2(e), 6(d)(ii) or 6(e)) or (2) receive a payment from which an amount has been deducted or withheld for or on account of any Indemnifiable Tax in respect of which the other party is not required to pay an additional amount (other than by reason of Section 2(d)(i)(4)(A) or (B)), in either case as a result of a party consolidating or amalgamating with, or merging with or into, or transferring all or substantially all its assets to, another entity (which will be the Affected Party) where such action does not constitute an event described in Section 5(a)(viii);

(iv) **Credit Event Upon Merger.** If “Credit Event Upon Merger” is specified in the Schedule as applying to the party, such party (“X”), any Credit Support Provider of X or any applicable Specified Entity of X consolidates or amalgamates with, or merges with or into, or transfers all or substantially all its assets to, another entity and such action does not constitute an event described in Section 5(a)(viii) but the creditworthiness of the resulting, surviving or transferee entity is materially weaker than that of X, such Credit Support Provider or such Specified Entity, as the case may be, immediately prior to such action (and, in such event, X or its successor or transferee, as appropriate, will be the Affected Party); or

(v) **Additional Termination Event.** If any “Additional Termination Event” is specified in the Schedule or any Confirmation as applying, the occurrence of such event (and, in such event, the Affected Party or Affected Parties shall be as specified for such Additional Termination Event in the Schedule or such Confirmation).

(c) **Event of Default and Illegality.** If an event or circumstance which would otherwise constitute or give rise to an Event of Default also constitutes an Illegality, it will be treated as an Illegality and will not constitute an Event of Default.

## 6. Early Termination

(a) **Right to Terminate Following Event of Default.** If at any time an Event of Default with respect to a party (the “Defaulting Party”) has occurred and is then continuing, the other party (the “Non-defaulting Party”) may, by not more than 20 days notice to the Defaulting Party specifying the relevant Event of Default, designate a day not earlier than the day such notice is effective as an Early Termination Date in respect of all outstanding Transactions. If, however, “Automatic Early Termination” is specified in the Schedule as applying to a party, then an Early Termination Date in respect of all outstanding Transactions will occur immediately upon the occurrence with respect to such party of an Event of Default specified in Section 5(a)(vii)(1), (3), (5), (6) or, to the extent analogous thereto, (8), and as of the time immediately preceding the institution of the relevant proceeding or the presentation of the relevant petition upon the occurrence with respect to such party of an Event of Default specified in Section 5(a)(vii)(4) or, to the extent analogous thereto, (8).

### (b) **Right to Terminate Following Termination Event.**

(i) **Notice.** If a Termination Event occurs, an Affected Party will, promptly upon becoming aware of it, notify the other party, specifying the nature of that Termination Event and each Affected Transaction and will also give such other information about that Termination Event as the other party may reasonably require.

(ii) **Transfer to Avoid Termination Event.** If either an Illegality under Section 5(b)(i)(1) or a Tax Event occurs and there is only one Affected Party, or if a Tax Event Upon Merger occurs and the Burdened Party is the Affected Party, the Affected Party will, as a condition to its right to designate an Early Termination Date under Section 6(b)(iv), use all reasonable efforts (which will not require such party to incur a loss, excluding immaterial, incidental expenses) to transfer within 20 days after it gives notice under Section 6(b)(i) all its rights and obligations under this Agreement in respect of the Affected Transactions to another of its Offices or Affiliates so that such Termination Event ceases to exist.

If the Affected Party is not able to make such a transfer it will give notice to the other party to that effect within such 20 day period, whereupon the other party may effect such a transfer within 30 days after the notice is given under Section 6(b)(i).

Any such transfer by a party under this Section 6(b)(ii) will be subject to and conditional upon the prior written consent of the other party, which consent will not be withheld if such other party’s policies in effect at such time would permit it to enter into transactions with the transferee on the terms proposed.

(iii) **Two Affected Parties.** If an Illegality under Section 5(b)(i)(1) or a Tax Event occurs and there are two Affected Parties, each party will use all reasonable efforts to reach agreement within 30 days after notice thereof is given under Section 6(b)(i) on action to avoid that Termination Event.

(iv) **Right to Terminate.** If: —

(1) a transfer under Section 6(b)(ii) or an agreement under Section 6(b)(iii), as the case may be, has not been effected with respect to all Affected Transactions within 30 days after an Affected Party gives notice under Section 6(b)(i); or

(2) an Illegality under Section 5(b)(i)(2), a Credit Event Upon Merger or an Additional Termination Event occurs, or a Tax Event Upon Merger occurs and the Burdened Party is not the Affected Party,

either party in the case of an Illegality, the Burdened Party in the case of a Tax Event Upon Merger, any Affected Party in the case of a Tax Event or an Additional Termination Event if there is more than one Affected Party, or the party which is not the Affected Party in the case of a Credit Event Upon Merger or an Additional Termination Event if there is only one Affected Party may, by not more than 20 days notice to the other party and provided that the relevant Termination Event is then

continuing, designate a day not earlier than the day such notice is effective as an Early Termination Date in respect of all Affected Transactions.

**(c) Effect of Designation.**

- (i) If notice designating an Early Termination Date is given under Section 6(a) or (b), the Early Termination Date will occur on the date so designated, whether or not the relevant Event of Default or Termination Event is then continuing.
- (ii) Upon the occurrence or effective designation of an Early Termination Date, no further payments or deliveries under Section 2(a)(i) or 2(e) in respect of the Terminated Transactions will be required to be made, but without prejudice to the other provisions of this Agreement. The amount, if any, payable in respect of an Early Termination Date shall be determined pursuant to Section 6(e).

**(d) Calculations.**

(i) **Statement.** On or as soon as reasonably practicable following the occurrence of an Early Termination Date, each party will make the calculations on its part, if any, contemplated by Section 6(e) and will provide to the other party a statement (1) showing, in reasonable detail, such calculations (including all relevant quotations and specifying any amount payable under Section 6(e)) and (2) giving details of the relevant account to which any amount payable to it is to be paid. In the absence of written confirmation from the source of a quotation obtained in determining a Market Quotation, the records of the party obtaining such quotation will be conclusive evidence of the existence and accuracy of such quotation.

(ii) **Payment Date.** An amount calculated as being due in respect of any Early Termination Date under Section 6(e) will be payable on the day that notice of the amount payable is effective (in the case of an Early Termination Date which is designated or occurs as a result of an Event of Default) and on the day which is two Local Business Days after the day on which notice of the amount payable is effective (in the case of an Early Termination Date which is designated as a result of a Termination Event). Such amount will be paid together with (to the extent permitted under applicable law) interest thereon (before as well as after judgment) in the Termination Currency, from (and including) the relevant Early Termination Date to (but excluding) the date such amount is paid, at the Applicable Rate. Such interest will be calculated on the basis of daily compounding and the actual number of days elapsed.

**(e) Payments on Early Termination.** If an Early Termination Date occurs, the following provisions shall apply based on the parties' election in the Schedule of a payment measure, either "Market Quotation" or "Loss", and a payment method, either the "First Method" or the "Second Method". If the parties fail to designate a payment measure or payment method in the Schedule, it will be deemed that "Market Quotation" or the "Second Method", as the case may be, shall apply. The amount, if any, payable in respect of an Early Termination Date and determined pursuant to this Section will be subject to any Set-off.

(i) **Events of Default.** If the Early Termination Date results from an Event of Default: —

(1) **First Method and Market Quotation.** If the First Method and Market Quotation apply, the Defaulting Party will pay to the Non-defaulting Party the excess, if a positive number, of (A) the sum of the Settlement Amount (determined by the Non-defaulting Party) in respect of the Terminated Transactions and the Termination Currency Equivalent of the Unpaid Amounts owing to the Non-defaulting Party over (B) the Termination Currency Equivalent of the Unpaid Amounts owing to the Defaulting Party.

(2) **First Method and Loss.** If the First Method and Loss apply, the Defaulting Party will pay to the Non-defaulting Party, if a positive number, the Non-defaulting Party's Loss in respect of this Agreement.

(3) **Second Method and Market Quotation.** If the Second Method and Market Quotation apply, an amount will be payable equal to (A) the sum of the Settlement Amount (determined by the

Non-defaulting Party) in respect of the Terminated Transactions and the Termination Currency Equivalent of the Unpaid Amounts owing to the Non-defaulting Party less (B) the Termination Currency Equivalent of the Unpaid Amounts owing to the Defaulting Party. If that amount is a positive number, the Defaulting Party will pay it to the Non-defaulting Party; if it is a negative number, the Non-defaulting Party will pay the absolute value of that amount to the Defaulting Party.

(4) **Second Method and Loss.** If the Second Method and Loss apply, an amount will be payable equal to the Non-defaulting Party's Loss in respect of this Agreement. If that amount is a positive number, the Defaulting Party will pay it to the Non-defaulting Party; if it is a negative number, the Non-defaulting Party will pay the absolute value of that amount to the Defaulting Party.

(ii) **Termination Events.** If the Early Termination Date results from a Termination Event: —

(1) **One Affected Party.** If there is one Affected Party, the amount payable will be determined in accordance with Section 6(e)(i)(3), if Market Quotation applies, or Section 6(e)(i)(4), if Loss applies, except that, in either case, references to the Defaulting Party and to the Non-defaulting Party will be deemed to be references to the Affected Party and the party which is not the Affected Party, respectively, and, if Loss applies and fewer than all the Transactions are being terminated, Loss shall be calculated in respect of all Terminated Transactions.

(2) **Two Affected Parties.** If there are two Affected Parties: —

(A) if Market Quotation applies, each party will determine a Settlement Amount in respect of the Terminated Transactions, and an amount will be payable equal to (I) the sum of (a) one-half of the difference between the Settlement Amount of the party with the higher Settlement Amount ("X") and the Settlement Amount of the party with the lower Settlement Amount ("Y") and (b) the Termination Currency Equivalent of the Unpaid Amounts owing to X less (II) the Termination Currency Equivalent of the Unpaid Amounts owing to Y; and

(B) if Loss applies, each party will determine its Loss in respect of this Agreement (or, if fewer than all the Transactions are being terminated, in respect of all Terminated Transactions) and an amount will be payable equal to one-half of the difference between the Loss of the party with the higher Loss ("X") and the Loss of the party with the lower Loss ("Y").

If the amount payable is a positive number, Y will pay it to X; if it is a negative number, X will pay the absolute value of that amount to Y.

(iii) **Adjustment for Bankruptcy.** In circumstances where an Early Termination Date occurs because "Automatic Early Termination" applies in respect of a party, the amount determined under this Section 6(e) will be subject to such adjustments as are appropriate and permitted by law to reflect any payments or deliveries made by one party to the other under this Agreement (and retained by such other party) during the period from the relevant Early Termination Date to the date for payment determined under Section 6(d)(ii).

(iv) **Pre-Estimate.** The parties agree that if Market Quotation applies an amount recoverable under this Section 6(e) is a reasonable pre-estimate of loss and not a penalty. Such amount is payable for the loss of bargain and the loss of protection against future risks and except as otherwise provided in this Agreement neither party will be entitled to recover any additional damages as a consequence of such losses.



## 7. Transfer

Subject to Section 6(b)(ii), neither this Agreement nor any interest or obligation in or under this Agreement may be transferred (whether by way of security or otherwise) by either party without the prior written consent of the other party, except that: —

- (a) a party may make such a transfer of this Agreement pursuant to a consolidation or amalgamation with, or merger with or into, or transfer of all or substantially all its assets to, another entity (but without prejudice to any other right or remedy under this Agreement); and
- (b) a party may make such a transfer of all or any part of its interest in any amount payable to it from a Defaulting Party under Section 6(e).

Any purported transfer that is not in compliance with this Section will be void.

## 8. Contractual Currency

(a) **Payment in the Contractual Currency.** Each payment under this Agreement will be made in the relevant currency specified in this Agreement for that payment (the “Contractual Currency”). To the extent permitted by applicable law, any obligation to make payments under this Agreement in the Contractual Currency will not be discharged or satisfied by any tender in any currency other than the Contractual Currency, except to the extent such tender results in the actual receipt by the party to which payment is owed, acting in a reasonable manner and in good faith in converting the currency so tendered into the Contractual Currency, of the full amount in the Contractual Currency of all amounts payable in respect of this Agreement. If for any reason the amount in the Contractual Currency so received falls short of the amount in the Contractual Currency payable in respect of this Agreement, the party required to make the payment will, to the extent permitted by applicable law, immediately pay such additional amount in the Contractual Currency as may be necessary to compensate for the shortfall. If for any reason the amount in the Contractual Currency so received exceeds the amount in the Contractual Currency payable in respect of this Agreement, the party receiving the payment will refund promptly the amount of such excess.

(b) **Judgments.** To the extent permitted by applicable law, if any judgment or order expressed in a currency other than the Contractual Currency is rendered (i) for the payment of any amount owing in respect of this Agreement, (ii) for the payment of any amount relating to any early termination in respect of this Agreement or (iii) in respect of a judgment or order of another court for the payment of any amount described in (i) or (ii) above, the party seeking recovery, after recovery in full of the aggregate amount to which such party is entitled pursuant to the judgment or order, will be entitled to receive immediately from the other party the amount of any shortfall of the Contractual Currency received by such party as a consequence of sums paid in such other currency and will refund promptly to the other party any excess of the Contractual Currency received by such party as a consequence of sums paid in such other currency if such shortfall or such excess arises or results from any variation between the rate of exchange at which the Contractual Currency is converted into the currency of the judgment or order for the purposes of such judgment or order and the rate of exchange at which such party is able, acting in a reasonable manner and in good faith in converting the currency received into the Contractual Currency, to purchase the Contractual Currency with the amount of the currency of the judgment or order actually received by such party. The term “rate of exchange” includes, without limitation, any premiums and costs of exchange payable in connection with the purchase of or conversion into the Contractual Currency.

(c) **Separate Indemnities.** To the extent permitted by applicable law, these indemnities constitute separate and independent obligations from the other obligations in this Agreement, will be enforceable as separate and independent causes of action, will apply notwithstanding any indulgence granted by the party to which any payment is owed and will not be affected by judgment being obtained or claim or proof being made for any other sums payable in respect of this Agreement.

(d) **Evidence of Loss.** For the purpose of this Section 8, it will be sufficient for a party to demonstrate that it would have suffered a loss had an actual exchange or purchase been made.

## 9. Miscellaneous

- (a) **Entire Agreement.** This Agreement constitutes the entire agreement and understanding of the parties with respect to its subject matter and supersedes all oral communication and prior writings with respect thereto.
- (b) **Amendments.** No amendment, modification or waiver in respect of this Agreement will be effective unless in writing (including a writing evidenced by a facsimile transmission) and executed by each of the parties or confirmed by an exchange of telexes or electronic messages on an electronic messaging system.
- (c) **Survival of Obligations.** Without prejudice to Sections 2(a)(iii) and 6(c)(ii), the obligations of the parties under this Agreement will survive the termination of any Transaction.
- (d) **Remedies Cumulative.** Except as provided in this Agreement, the rights, powers, remedies and privileges provided in this Agreement are cumulative and not exclusive of any rights, powers, remedies and privileges provided by law.
- (e) **Counterparts and Confirmations.**
- (i) This Agreement (and each amendment, modification and waiver in respect of it) may be executed and delivered in counterparts (including by facsimile transmission), each of which will be deemed an original.
  - (ii) The parties intend that they are legally bound by the terms of each Transaction from the moment they agree to those terms (whether orally or otherwise). A Confirmation shall be entered into as soon as practicable and may be executed and delivered in counterparts (including by facsimile transmission) or be created by an exchange of telexes or by an exchange of electronic messages on an electronic messaging system, which in each case will be sufficient for all purposes to evidence a binding supplement to this Agreement. The parties will specify therein or through another effective means that any such counterpart, telex or electronic message constitutes a Confirmation.
- (f) **No Waiver of Rights.** A failure or delay in exercising any right, power or privilege in respect of this Agreement will not be presumed to operate as a waiver, and a single or partial exercise of any right, power or privilege will not be presumed to preclude any subsequent or further exercise, of that right, power or privilege or the exercise of any other right, power or privilege.
- (g) **Headings.** The headings used in this Agreement are for convenience of reference only and are not to affect the construction of or to be taken into consideration in interpreting this Agreement.

## 10. Offices; Multibranch Parties

- (a) If Section 10(a) is specified in the Schedule as applying, each party that enters into a Transaction through an Office other than its head or home office represents to the other party that, notwithstanding the place of booking office or jurisdiction of incorporation or organisation of such party, the obligations of such party are the same as if it had entered into the Transaction through its head or home office. This representation will be deemed to be repeated by such party on each date on which a Transaction is entered into.
- (b) Neither party may change the Office through which it makes and receives payments or deliveries for the purpose of a Transaction without the prior written consent of the other party.
- (c) If a party is specified as a Multibranch Party in the Schedule, such Multibranch Party may make and receive payments or deliveries under any Transaction through any Office listed in the Schedule, and the Office through which it makes and receives payments or deliveries with respect to a Transaction will be specified in the relevant Confirmation.

## 11. Expenses

A Defaulting Party will, on demand, indemnify and hold harmless the other party for and against all reasonable out-of-pocket expenses, including legal fees and Stamp Tax, incurred by such other party by reason of the enforcement and protection of its rights under this Agreement or any Credit Support Document

to which the Defaulting Party is a party or by reason of the early termination of any Transaction, including, but not limited to, costs of collection.

## 12. Notices

(a) **Effectiveness.** Any notice or other communication in respect of this Agreement may be given in any manner set forth below (except that a notice or other communication under Section 5 or 6 may not be given by facsimile transmission or electronic messaging system) to the address or number or in accordance with the electronic messaging system details provided (see the Schedule) and will be deemed effective as indicated:—

- (i) if in writing and delivered in person or by courier, on the date it is delivered;
- (ii) if sent by telex, on the date the recipient's answerback is received;
- (iii) if sent by facsimile transmission, on the date that transmission is received by a responsible employee of the recipient in legible form (it being agreed that the burden of proving receipt will be on the sender and will not be met by a transmission report generated by the sender's facsimile machine);
- (iv) if sent by certified or registered mail (airmail, if overseas) or the equivalent (return receipt requested), on the date that mail is delivered or its delivery is attempted; or
- (v) if sent by electronic messaging system, on the date that electronic message is received,

unless the date of that delivery (or attempted delivery) or that receipt, as applicable, is not a Local Business Day or that communication is delivered (or attempted) or received, as applicable, after the close of business on a Local Business Day, in which case that communication shall be deemed given and effective on the first following day that is a Local Business Day.

(b) **Change of Addresses.** Either party may by notice to the other change the address, telex or facsimile number or electronic messaging system details at which notices or other communications are to be given to it.

## 13. Governing Law and Jurisdiction

(a) **Governing Law.** This Agreement will be governed by and construed in accordance with the law specified in the Schedule.

(b) **Jurisdiction.** With respect to any suit, action or proceedings relating to this Agreement ("Proceedings"), each party irrevocably:—

- (i) submits to the jurisdiction of the English courts, if this Agreement is expressed to be governed by English law, or to the non-exclusive jurisdiction of the courts of the State of New York and the United States District Court located in the Borough of Manhattan in New York City, if this Agreement is expressed to be governed by the laws of the State of New York; and
- (ii) waives any objection which it may have at any time to the laying of venue of any Proceedings brought in any such court, waives any claim that such Proceedings have been brought in an inconvenient forum and further waives the right to object, with respect to such Proceedings, that such court does not have any jurisdiction over such party.

Nothing in this Agreement precludes either party from bringing Proceedings in any other jurisdiction (outside, if this Agreement is expressed to be governed by English law, the Contracting States, as defined in Section 1(3) of the Civil Jurisdiction and Judgments Act 1982 or any modification, extension or re-enactment thereof for the time being in force) nor will the bringing of Proceedings in any one or more jurisdictions preclude the bringing of Proceedings in any other jurisdiction.

(c) **Service of Process.** Each party irrevocably appoints the Process Agent (if any) specified opposite its name in the Schedule to receive, for it and on its behalf, service of process in any Proceedings. If for any

reason any party's Process Agent is unable to act as such, such party will promptly notify the other party and within 30 days appoint a substitute process agent acceptable to the other party. The parties irrevocably consent to service of process given in the manner provided for notices in Section 12. Nothing in this Agreement will affect the right of either party to serve process in any other manner permitted by law.

(d) **Waiver of Immunities.** Each party irrevocably waives, to the fullest extent permitted by applicable law, with respect to itself and its revenues and assets (irrespective of their use or intended use), all immunity on the grounds of sovereignty or other similar grounds from (i) suit, (ii) jurisdiction of any court, (iii) relief by way of injunction, order for specific performance or for recovery of property, (iv) attachment of its assets. (whether before or after judgment) and (v) execution or enforcement of any judgment to which it or its revenues or assets might otherwise be entitled in any Proceedings in the courts of any jurisdiction and irrevocably agrees, to the extent permitted by applicable law, that it will not claim any such immunity in any Proceedings.

#### 14. Definitions

As used in this Agreement:—

**"Additional Termination Event"** has the meaning specified in Section 5(b).

**"Affected Party"** has the meaning specified in Section 5(b).

**"Affected Transactions"** means (a) with respect to any Termination Event consisting of an Illegality, Tax Event or Tax Event Upon Merger, all Transactions affected by the occurrence of such Termination Event and (b) with respect to any other Termination Event, all Transactions.

**"Affiliate"** means, subject to the Schedule, in relation to any person, any entity controlled, directly or indirectly, by the person, any entity that controls, directly or indirectly, the person or any entity directly or indirectly under common control with the person. For this purpose, "control" of any entity or person means ownership of a majority of the voting power of the entity or person.

**"Applicable Rate"** means:—

(a) in respect of obligations payable or deliverable (or which would have been but for Section 2(a)(iii)) by a Defaulting Party, the Default Rate;

(b) in respect of an obligation to pay an amount under Section 6(e) of either party from and after the date (determined in accordance with Section 6(d)(ii)) on which that amount is payable, the Default Rate;

(c) in respect of all other obligations payable or deliverable (or which would have been but for Section 2(a)(iii)) by a Non-defaulting Party, the Non-default Rate; and

(d) in all other cases, the Termination Rate.

**"Burdened Party"** has the meaning specified in Section 5(b).

**"Change in Tax Law"** means the enactment, promulgation, execution or ratification of, or any change in or amendment to, any law (or in the application or official interpretation of any law) that occurs on or after the date on which the relevant Transaction is entered into.

**"consent"** includes a consent, approval, action, authorisation, exemption, notice, filing, registration or exchange control consent.

**"Credit Event Upon Merger"** has the meaning specified in Section 5(b).

**"Credit Support Document"** means any agreement or instrument that is specified as such in this Agreement.

**"Credit Support Provider"** has the meaning specified in the Schedule.

**"Default Rate"** means a rate per annum equal to the cost (without proof or evidence of any actual cost) to the relevant payee (as certified by it) if it were to fund or of funding the relevant amount plus 1% per annum.

**“Defaulting Party”** has the meaning specified in Section 6(a).

**“Early Termination Date”** means the date determined in accordance with Section 6(a) or 6(b)(iv).

**“Event of Default”** has the meaning specified in Section 5(a) and, if applicable, in the Schedule.

**“Illegality”** has the meaning specified in Section 5(b).

**“Indemnifiable Tax”** means any Tax other than a Tax that would not be imposed in respect of a payment under this Agreement but for a present or former connection between the jurisdiction of the government or taxation authority imposing such Tax and the recipient of such payment or a person related to such recipient (including, without limitation, a connection arising from such recipient or related person being or having been a citizen or resident of such jurisdiction, or being or having been organised, present or engaged in a trade or business in such jurisdiction, or having or having had a permanent establishment or fixed place of business in such jurisdiction, but excluding a connection arising solely from such recipient or related person having executed, delivered, performed its obligations or received a payment under, or enforced, this Agreement or a Credit Support Document).

**“law”** includes any treaty, law, rule or regulation (as modified, in the case of tax matters, by the practice of any relevant governmental revenue authority) and **“lawful”** and **“unlawful”** will be construed accordingly.

**“Local Business Day”** means, subject to the Schedule, a day on which commercial banks are open for business (including dealings in foreign exchange and foreign currency deposits) (a) in relation to any obligation under Section 2(a)(i), in the place(s) specified in the relevant Confirmation or, if not so specified, as otherwise agreed by the parties in writing or determined pursuant to provisions contained, or incorporated by reference, in this Agreement, (b) in relation to any other payment, in the place where the relevant account is located and, if different, in the principal financial centre, if any, of the currency of such payment, (c) in relation to any notice or other communication, including notice contemplated under Section 5(a)(i), in the city specified in the address for notice provided by the recipient and, in the case of a notice contemplated by Section 2(b), in the place where the relevant new account is to be located and (d) in relation to Section 5(a)(v)(2), in the relevant locations for performance with respect to such Specified Transaction.

**“Loss”** means, with respect to this Agreement or one or more Terminated Transactions, as the case may be, and a party, the Termination Currency Equivalent of an amount that party reasonably determines in good faith to be its total losses and costs (or gain, in which case expressed as a negative number) in connection with this Agreement or that Terminated Transaction or group of Terminated Transactions, as the case may be, including any loss of bargain, cost of funding or, at the election of such party but without duplication, loss or cost incurred as a result of its terminating, liquidating, obtaining or reestablishing any hedge or related trading position (or any gain resulting from any of them). Loss includes losses and costs (or gains) in respect of any payment or delivery required to have been made (assuming satisfaction of each applicable condition precedent) on or before the relevant Early Termination Date and not made, except, so as to avoid duplication, if Section 6(e)(i)(1) or (3) or 6(e)(ii)(2) (A) applies. Loss does not include a party’s legal fees and out-of-pocket expenses referred to under Section 11. A party will determine its Loss as of the relevant Early Termination Date, or, if that is not reasonably practicable, as of the earliest date thereafter as is reasonably practicable. A party may (but need not) determine its Loss by reference to quotations of relevant rates or prices from one or more leading dealers in the relevant markets.

**“Market Quotation”** means, with respect to one or more Terminated Transactions and a party making the determination, an amount determined on the basis of quotations from Reference Market-makers. Each quotation will be for an amount, if any, that would be paid to such party (expressed as a negative number) or by such party (expressed as a positive number) in consideration of an agreement between such party (taking into account any existing Credit Support Document with respect to the obligations of such party) and the quoting Reference Market-maker to enter into a transaction (the “Replacement Transaction”) that would have the effect of preserving for such party the economic equivalent of any payment or delivery (whether the underlying obligation was absolute or contingent and assuming the satisfaction of each applicable condition precedent) by the parties under Section 2(a)(i) in respect of such Terminated Transaction or group of Terminated Transactions that would, but for the occurrence of the relevant Early Termination Date, have

been required after that date. For this purpose, Unpaid Amounts in respect of the Terminated Transaction or group of Terminated Transactions are to be excluded but, without limitation, any payment or delivery that would, but for the relevant Early Termination Date, have been required (assuming satisfaction of each applicable condition precedent) after that Early Termination Date is to be included. The Replacement Transaction would be subject to such documentation as such party and the Reference Market-maker may, in good faith, agree. The party making the determination (or its agent) will request each Reference Market-maker to provide its quotation to the extent reasonably practicable as of the same day and time (without regard to different time zones) on or as soon as reasonably practicable after the relevant Early Termination Date. The day and time as of which those quotations are to be obtained will be selected in good faith by the party obliged to make a determination under Section 6(e), and, if each party is so obliged, after consultation with the other. If more than three quotations are provided, the Market Quotation will be the arithmetic mean of the quotations, without regard to the quotations having the highest and lowest values. If exactly three such quotations are provided, the Market Quotation will be the quotation remaining after disregarding the highest and lowest quotations. For this purpose, if more than one quotation has the same highest value or lowest value, then one of such quotations shall be disregarded. If fewer than three quotations are provided, it will be deemed that the Market Quotation in respect of such Terminated Transaction or group of Terminated Transactions cannot be determined.

**“Non-default Rate”** means a rate per annum equal to the cost (without proof or evidence of any actual cost) to the Non-defaulting Party (as certified by it) if it were to fund the relevant amount.

**“Non-defaulting Party”** has the meaning specified in Section 6(a).

**“Office”** means a branch or office of a party, which may be such party’s head or home office.

**“Potential Event of Default”** means any event which, with the giving of notice or the lapse of time or both, would constitute an Event of Default.

**“Reference Market-makers”** means four leading dealers in the relevant market selected by the party determining a Market Quotation in good faith (a) from among dealers of the highest credit standing which satisfy all the criteria that such party applies generally at the time in deciding whether to offer or to make an extension of credit and (b) to the extent practicable, from among such dealers having an office in the same city.

**“Relevant Jurisdiction”** means, with respect to a party, the jurisdictions (a) in which the party is incorporated, organised, managed and controlled or considered to have its seat, (b) where an Office through which the party is acting for purposes of this Agreement is located, (c) in which the party executes this Agreement and (d) in relation to any payment, from or through which such payment is made.

**“Scheduled Payment Date”** means a date on which a payment or delivery is to be made under Section 2(a)(i) with respect to a Transaction.

**“Set-off”** means set-off, offset, combination of accounts, right of retention or withholding or similar right or requirement to which the payer of an amount under Section 6 is entitled or subject (whether arising under this Agreement, another contract, applicable law or otherwise) that is exercised by, or imposed on, such payer.

**“Settlement Amount”** means, with respect to a party and any Early Termination Date, the sum of: —

(a) the Termination Currency Equivalent of the Market Quotations (whether positive or negative) for each Terminated Transaction or group of Terminated Transactions for which a Market Quotation is determined; and

(b) such party’s Loss (whether positive or negative and without reference to any Unpaid Amounts) for each Terminated Transaction or group of Terminated Transactions for which a Market Quotation cannot be determined or would not (in the reasonable belief of the party making the determination) produce a commercially reasonable result.

**“Specified Entity”** has the meanings specified in the Schedule.

**“Specified Indebtedness”** means, subject to the Schedule, any obligation (whether present or future, contingent or otherwise, as principal or surety or otherwise) in respect of borrowed money.

**“Specified Transaction”** means, subject to the Schedule, (a) any transaction (including an agreement with respect thereto) now existing or hereafter entered into between one party to this Agreement (or any Credit Support Provider of such party or any applicable Specified Entity of such party) and the other party to this Agreement (or any Credit Support Provider of such other party or any applicable Specified Entity of such other party) which is a rate swap transaction, basis swap, forward rate transaction, commodity swap, commodity option, equity or equity index swap, equity or equity index option, bond option, interest rate option, foreign exchange transaction, cap transaction, floor transaction, collar transaction, currency swap transaction, cross-currency rate swap transaction, currency option or any other similar transaction (including any option with respect to any of these transactions), (b) any combination of these transactions and (c) any other transaction identified as a Specified Transaction in this Agreement or the relevant confirmation.

**“Stamp Tax”** means any stamp, registration, documentation or similar tax.

**“Tax”** means any present or future tax, levy, impost, duty, charge, assessment or fee of any nature (including interest, penalties and additions thereto) that is imposed by any government or other taxing authority in respect of any payment under this Agreement other than a stamp, registration, documentation or similar tax.

**“Tax Event”** has the meaning specified in Section 5(b).

**“Tax Event Upon Merger”** has the meaning specified in Section 5(b).

**“Terminated Transactions”** means with respect to any Early Termination Date (a) if resulting from a Termination Event, all Affected Transactions and (b) if resulting from an Event of Default, all Transactions (in either case) in effect immediately before the effectiveness of the notice designating that Early Termination Date (or, if “Automatic Early Termination” applies, immediately before that Early Termination Date).

**“Termination Currency”** has the meaning specified in the Schedule.

**“Termination Currency Equivalent”** means, in respect of any amount denominated in the Termination Currency, such Termination Currency amount and, in respect of any amount denominated in a currency other than the Termination Currency (the “Other Currency”), the amount in the Termination Currency determined by the party making the relevant determination as being required to purchase such amount of such Other Currency as at the relevant Early Termination Date, or, if the relevant Market Quotation or Loss (as the case may be), is determined as of a later date, that later date, with the Termination Currency at the rate equal to the spot exchange rate of the foreign exchange agent (selected as provided below) for the purchase of such Other Currency with the Termination Currency at or about 11:00 a.m. (in the city in which such foreign exchange agent is located) on such date as would be customary for the determination of such a rate for the purchase of such Other Currency for value on the relevant Early Termination Date or that later date. The foreign exchange agent will, if only one party is obliged to make a determination under Section 6(e), be selected in good faith by that party and otherwise will be agreed by the parties.

**“Termination Event”** means an Illegality, a Tax Event or a Tax Event Upon Merger or, if specified to be applicable, a Credit Event Upon Merger or an Additional Termination Event.

**“Termination Rate”** means a rate per annum equal to the arithmetic mean of the cost (without proof or evidence of any actual cost) to each party (as certified by such party) if it were to fund or of funding such amounts.

**“Unpaid Amounts”** owing to any party means, with respect to an Early Termination Date, the aggregate of (a) in respect of all Terminated Transactions, the amounts that became payable (or that would have become payable but for Section 2(a)(iii)) to such party under Section 2(a)(i) on or prior to such Early Termination Date and which remain unpaid as at such Early Termination Date and (b) in respect of each Terminated Transaction, for each obligation under Section 2(a)(i) which was (or would have been but for Section 2(a)(iii)) required to be settled by delivery to such party on or prior to such Early Termination Date and which has not been so settled as at such Early Termination Date, an amount equal to the fair market

value of that which was (or would have been) required to be delivered as of the originally scheduled date for delivery, in each case together with (to the extent permitted under applicable law) interest, in the currency of such amounts, from (and including) the date such amounts or obligations were or would have been required to have been paid or performed to (but excluding) such Early Termination Date, at the Applicable Rate. Such amounts of interest will be calculated on the basis of daily compounding and the actual number of days elapsed. The fair market value of any obligation referred to in clause (b) above shall be reasonably determined by the party obliged to make the determination under Section 6(e) or, if each party is so obliged, it shall be the average of the Termination Currency Equivalents of the fair market values reasonably determined by both parties.

IN WITNESS WHEREOF the parties have executed this document on the respective dates specified below with effect from the date specified on the first page of this document.

**Credit Suisse First Boston International**  
(Name of Party)

By: /s/ Carole Villoresi  
Name: Carole Villoresi  
Title: Authorized Signatory  
Date:

By: /s/ Barry Dixon  
Name: Barry Dixon  
Title: Authorized Signatory  
Date:

**Cheniere LNG Holdings, LLC**  
(Name of Party)

By: /s/ Graham McArthur  
Name: Graham McArthur  
Title: Treasurer  
Date: 12/23/05



Schedule  
to the  
Master Agreement

dated as of December 23, 2005

between

**Credit Suisse First Boston International**  
an unlimited company incorporated  
under the laws of England and Wales  
("Party A")

and

**Cheniere LNG Holdings, LLC**  
a limited liability company incorporated  
under the laws of Delaware  
("Party B")

**Part 1**  
**Termination Provisions**

In this Agreement:

(a) **Specified Entity.** "Specified Entity" means, in relation to Party A, for the purpose of:

Section 5(a)(v):	Affiliates
Section 5(a)(vi):	Not Applicable
Section 5(a)(vii):	Not Applicable
Section 5(b)(iv):	Not Applicable

in relation to Party B, for the purpose of:

Section 5(a)(v):	Any Subsidiary as defined below
Section 5(a)(vi):	Not Applicable
Section 5(a)(vii):	Not Applicable
Section 5(b)(iv):	Not Applicable

"Subsidiary" shall mean the term "Subsidiary" as defined in the Credit Agreement described in Part 4 (f) below.

(b) **Specified Transaction.** Specified Transaction will have the meaning specified in Section 14.

(c) **Cross Default.** The "Cross Default" provision (Section 5(a)(vi)) will apply to Party A and Party B. For Party A the Threshold Amount is \$10,000,000

In the case of Party B the only agreement or instrument that shall apply for purposes of either sub paragraph (1) or (2) of Section 5(a)(vi) is a default by Party B under the Credit Agreement, described in Part 4 (f). For purposes of this provision, Cross Default will apply as the result of (i) any payment default under the Credit Agreement without regard to any Threshold Amount; or (ii) the occurrence of another Event of Default under the Credit Agreement that results in the outstanding Debt thereunder being declared due and payable.

---

**(d) Credit Event Upon Merger.** The “Credit Event Upon Merger” provision (Section 5(b)(iv)) will apply to Party A and Party B.

**(e) Automatic Early Termination.** The “Automatic Early Termination” provision of Section 6(a) will apply to Party A and Party B.

**(f) Payments on Early Termination.** For the purpose of Section 6(e), the Second Method and Loss will apply.

**(g) Termination Currency.** “Termination Currency” means United States Dollars.

**(h) Additional Termination Event.** The following Additional Termination Event will apply:

the Additional Termination Event as set forth in Part 5(k) of the Schedule to this Agreement; for the purpose of the foregoing, Party B shall be deemed to be the Affected Party and all Transactions shall be Affected Transactions.

---

**Part 2**  
**Tax Representations**

**(a) Payer Tax Representations.** For the purpose of Section 3(e), Party A and Party B each makes the following representation:

It is not required by any applicable law, as modified by the practice of any relevant governmental revenue authority, of any Relevant Jurisdiction to make any deduction or withholding for or on account of any Tax from any payment (other than interest under Section 2(e), 6(d)(ii) or 6(e)) to be made by it to the other party under this Agreement. In making this representation, it may rely on:

- (i) the accuracy of any representation made by the other party pursuant to Section 3(f);
- (ii) the satisfaction of the agreement of the other party contained in Section 4(a)(i) or 4(a)(iii) and the accuracy and effectiveness of any document provided by the other party pursuant to Section 4(a)(i) or 4(a)(iii); and
- (iii) the satisfaction of the agreement of the other party contained in Section 4(d);

provided that it shall not be a breach of this representation where reliance is placed on clause (ii), and the other party does not deliver a form or document under Section 4(a)(iii) by reason of material prejudice to its legal or commercial position.

**(b) Payee Tax Representations.** For the purpose of Section 3(f),

- (i) Party A makes the following Payee Tax Representations:
  - (1) Party A is entering into each Transaction in the ordinary course of its trade as, and is, a recognized UK bank as defined in Section 840A of the UK Income and Corporation Taxes Act of 1988;
  - (2) Party A has been approved as a Withholding Foreign Partnership by the U.S. Internal Revenue Service;
  - (3) Party A's Withholding Foreign Partnership Employer Identification Number is 98-0330001; and
  - (4) Party A is a partnership that agrees to comply with any withholding obligation under Section 1446 of the U.S. Internal Revenue Code.
- (ii) Party B makes no Payee Tax Representations.

**Part 3**  
**Agreement to Deliver Documents**

Each party agrees to deliver the following documents as applicable:

(a) For the purpose of Section 4(a)(i), tax forms, documents or certificates to be delivered are:

Party A agrees to complete, accurately and in a manner reasonably satisfactory to Party B, to execute and to deliver to Party B a valid United States Internal Revenue Service Form W-8IMY, or any successor form, and any required attachments thereto upon execution of this Agreement

(b) For the purpose of Section 4(a)(ii), other documents to be delivered are:

<b>Party required to deliver document</b>	<b>Form/Document/ Certificate</b>	<b>Date by Which to be delivered</b>	<b>Covered by Section 3 (d) Representation</b>
Party A and Party B	Evidence reasonably satisfactory to the other party as to the names, true signatures and authority of the officers or officials signing this Agreement or any Confirmation on its behalf	Upon execution this Agreement and, if requested, upon execution of any Confirmation	Yes
Party A and Party B	A copy of the annual audited or certified financial statements for the most recently ended financial Year which in the case of Party A will be included in its annual report.	Upon request, or as soon as available	Yes
Party B	Certified resolutions evidencing necessary corporate authority and approvals with respect to the execution, delivery and performance by Party B of this Agreement and any Confirmation delivered thereunder on behalf of Party B	Upon Execution of the Agreement	Yes

**Part 4**  
**Miscellaneous**

**(a) Addresses for Notices.** For the purpose of Section 12(a):

(i) (1) Address for notices or communications to Party A (other than by facsimile):

Address: One Cabot Square  
London E14 4QJ  
England

Attention:

- (1) Head of Credit Risk Management;
- (2) Global Head of OTC Operations -  
Operations Department;
- (3) General Counsel Europe -  
Legal and Compliance Department

Swift: Credit Suisse First Boston International CSFP GB2L

(For all purposes.)

(2) For the purpose of facsimile notices or communications under this Agreement (other than a notice or communication under Section 5 or 6):

Facsimile No.: 44 020 7888 2686

Attention: General Counsel Europe - Legal and Compliance Department

Telephone number for oral confirmation of receipt of facsimile in legible form: 44 020 7888 2028

Designated responsible employee for the purposes of Section 12(a)(iii): Senior Legal Secretary

With a copy to:

Facsimile No. 44 020 7888 3715

Head of Credit Risk Management

With a copy to:

Facsimile No. 44 020 7888 9503

Global Head of OTC Operations - Operations Department

(ii) Address for notices or communications to Party B:

Address: Cheniere LNG Holdings LLC  
2215-B Renaissance Drive, Suite 5  
Las Vegas, NV 89119

Attention: Graham A. McArthur  
Treasurer

Telephone No.: 713-659-1361

Facsimile No.: 713-659-5459

(For all purposes.)

**(b) Process Agent.** For the purpose of Section 13(c):

Party A appoints as its Process Agent Credit Suisse First Boston LLC, One Madison Avenue, New York, NY 10010 (Attention: General Counsel, Legal and Compliance Department)

Party B appoints as its Process Agent: *[Not Applicable]*

---

**(c) Offices.** The provisions of Section 10(a) will apply to this Agreement.

**(d) Multibranch Party.** For the purpose of Section 10(c):

Party A is not a Multibranch Party.

Party B is not a Multibranch Party.

**(e) Calculation Agent.** The Calculation Agent is Party A unless otherwise agreed in a Confirmation in relation to the relevant Transaction.

**(f) Credit Support Documents.** Details of any Credit Support Document: For Party B, (i) the Credit Agreement dated as of August 31, 2005 among Cheniere LNG Holdings, LLC, as the Borrower, the various financial institutions and other persons from time to time parties thereto, and Credit Suisse, Cayman Island Branch, as the Collateral Agent and Administrative Agent (the "Credit Agreement"), (ii) (2) the Pledge Agreement (as defined in the Credit Agreement) and (3) the Security Agreement (as defined in the Credit Agreement) (collectively, the documents set forth are referred to herein as the "Security Documents")

**(g) Credit Support Provider.**

Credit Support Provider means in relation to Party A: *Not applicable*

Credit Support Provider means in relation to Party B the Pledgor under the Pledge Agreement defined in Part 4(f).

**(h) Governing Law.** This Agreement will be governed by and construed in accordance with the laws of the State of New York. Section 13(b) is hereby amended by: (i) deleting in the second line of subparagraph (i) thereof the word, "non-"; (ii) adding in the third line before the comma, "and each party irrevocably agrees to designate any Proceedings brought in the courts of the State of New York as 'commercial' on the Request for Judicial Intervention seeking assignment to the Commercial Division of the Supreme Court"; and (iii) inserting "in order to enforce any judgment obtained in any Proceedings referred to in the preceding sentence" immediately after the word, "jurisdiction" the first time it appears in the second sentence and deleting the remainder.

**(i) Netting of Payments.** Section 2(c)(ii) of this Agreement will apply to any Transactions from the date of this Agreement. Nevertheless, to reduce settlement risk and operational costs, the parties agree that they will endeavour to net across as many Transactions as practicable wherever the parties can administratively do so.

**(j) Affiliate.** Affiliate will have the meaning specified in Section 14.

**Part 5**  
**Other Provisions**

**(a) Scope of Agreement.** Any Specified Transaction (whether now existing or hereafter entered into) between the parties, the confirmation of which fails by its terms expressly to exclude application of this Agreement, shall be governed by and be subject to this Agreement. Any such confirmation shall be a "Confirmation", and any such Specified Transaction shall be a "Transaction", for all purposes of this Agreement.

**(b) Definitions.** Unless otherwise specified in a Confirmation, each Transaction between the parties shall be subject to the 2000 ISDA Definitions as published by the International Swaps and Derivatives Association, Inc. (the "2000 Definitions"), and will be governed in all relevant respects by the provisions of the 2000 Definitions, without regard to any amendments thereto subsequent to the date hereof. The provisions set forth in the 2000 Definitions are incorporated by reference in and shall be deemed a part of this Agreement except that references in the 2000 Definitions to a "Swap Transaction" shall be deemed references to a "Transaction" for purposes of this Agreement.

**(c) Confirmations.** Each Confirmation shall be substantially in the form of one of the Exhibits to the 2000 Definitions or in any other form that is published by the International Swaps and Derivatives Association, Inc. or in such other form as the parties may agree.

**(d) Relationship Between Parties.** The parties agree to amend Section 3 of this Agreement by the addition of the following provision at the end thereof and marked as subsection (g).

"(g) **Relationship Between Parties.** Each party will be deemed to represent to the other party on the date on which it enters into a Transaction that (absent a written agreement between the parties that expressly imposes affirmative obligations to the contrary for that Transaction):

"(i) **Non-Reliance.** It is acting for its own account, and it has made its own independent decisions to enter into that Transaction and as to whether that Transaction is appropriate or proper for it based upon its own judgment and upon advice from such advisers as it has deemed necessary. It is not relying on any communication (written or oral) of the other party as investment advice or as a recommendation to enter into that Transaction; it being understood that information and explanations related to the terms and conditions of a Transaction shall not be considered investment advice or a recommendation to enter into that Transaction. No communication (written or oral) received from the other party shall be deemed to be an assurance or guarantee as to the expected results of that Transaction.

"(ii) **Assessment and Understanding.** It is capable of assessing the merits of and understanding (on its own behalf or through independent professional advice), and understands and accepts, the terms, conditions and risks of that Transaction. It is also capable of assuming, and assumes, the risks of that Transaction.

"(iii) **Status of Parties.** The other party is not acting as a fiduciary for or an adviser to it in respect of that Transaction.

"(iv) **No Agency.** It is entering into this Agreement, including each Transaction, as principal and not as agent of any person or entity."

**(e) Change of Account.** Section 2(b) of this Agreement is hereby amended by the addition of the following after the word "delivery" in the first line thereof:

"to another account in the same legal and tax jurisdiction as the original account"

**(f) Escrow Payments.** If (whether by reason of the time difference between the cities in which payments are to be made or otherwise) it is not possible for simultaneous payments to be made on any date on which both parties are required to make payments hereunder, either party may at its option and in its sole discretion notify the other party that payments on that date are to be made in escrow. In this case deposit of the payment due earlier on that date shall be made by 2:00 p.m. (local time at the place for the earlier payment) on that date with an escrow agent

selected by the notifying party, accompanied by irrevocable payment instructions (i) to release the deposited payment to the intended recipient upon receipt by the escrow agent of the required deposit of the corresponding payment from the other party on the same date accompanied by irrevocable payment instructions to the same effect or (ii) if the required deposit of the corresponding payment is not made on that same date, to return the payment deposited to the party that paid it into escrow. The party that elects to have payments made in escrow shall pay all costs of the escrow arrangements.

**(g) Set-off.** Without affecting the provisions of this Agreement requiring the calculation of certain net payment amounts, all payments under this Agreement will be made without set-off or counterclaim; provided, however, that upon the designation of any Early Termination Date, in addition to and not in limitation of any other right or remedy (including any right to set-off, counterclaim, or otherwise withhold payment) under applicable law:

the Non-defaulting Party or the party that is not the Affected Party (in either case, "X") may, without prior notice to any person, set off any sum or obligation (whether or not arising under this Agreement, whether matured or unmatured and irrespective of the currency, place of payment or booking office of the sum or obligation) owed by the Defaulting Party or Affected Party (in either case, "Y") to X or to any Affiliate of X, against any sum or obligation (whether or not arising under this Agreement or any other agreement, whether matured or unmatured and irrespective of the currency, place of payment or booking office of the sum or obligation) owed by X or any Affiliate of X to Y, and, for this purpose, may convert one currency into another. If any sum or obligation is unascertained, X may in good faith estimate that sum or obligation and set off in respect of that estimate, subject to X or Y, as the case may be, accounting to the other party when such sum or obligation is ascertained.

Nothing in this Agreement shall be effective or deemed to create any charge under English law.

**(h) Recording of Conversation.** Each party to this Agreement acknowledges and agrees to the tape recording of conversations between the parties to this Agreement whether by one or other or both of the parties and each party hereby consents to such recordings being used as evidence in Proceedings.

**(i) Commodity Exchange Act.** Each party represents to the other party on and as of the date hereof and on each date on which a Transaction is entered into among them that:

- (i) such party is an "eligible contract participant" as defined in the U.S. Commodity Exchange Act, as amended (the "CEA");
- (ii) neither this Agreement nor any Transaction has been executed or traded on a "trading facility" as such term is defined in the CEA; and
- (iii) such party is entering into each Transaction in connection with its business or a line of business and the terms of this Agreement and each Transaction have been individually tailored and negotiated.

**(j) Waiver of Right to Trial by Jury.** Each party waives, to the fullest extent permitted by applicable law, any right it may have to a trial by jury in respect of any suit, action or proceeding relating to this Agreement or any Credit Support Document. Each party (i) certifies that no representative, agent or attorney of the other party or any Credit Support Provider has represented, expressly or otherwise, that such other party would not, in the event of such a suit action or proceeding, seek to enforce the foregoing waiver and (ii) acknowledges that it and the other party have been induced to enter into this Agreement and provide for any Credit Support Document, as applicable by, among other things, the mutual waivers and certifications in this Section.

**(k) Additional Representations and Obligations of Party B.** Party B represents and warrants to Party A and further covenants that its payment obligations hereunder (or with respect to any Transaction) are or shall be secured *pari passu* in all respects and at all times with all of Party B's senior secured obligations. It shall constitute an Additional Termination Event (with Party B as the sole Affected Party) if at any time the "Collateral" (as defined in the Credit Agreement ) fails to secure Party B's obligations to Party A hereunder (or under any and all particular Transactions to which Party B is a party) to the same extent as such Collateral secures Party B's Obligations under the Loan Documents (as such capitalized terms are defined in the Credit Agreement) and the payment obligations



---

hereunder (or under any and all particular Transactions to which Party B is a party) fail to rank at least *pari passu* in all respects and at all times with all of Party B's other Obligations under the Credit Agreement.

**IN WITNESS WHEREOF**, the parties hereto have executed this document as of the date specified on the first page hereof.

**Credit Suisse First Boston International**

By:           /s/ Carole Villoresi            
Name: Carole Villoresi  
Title: Authorized Signatory  
Date:

By:           /s/ Barry Dixon            
Name: Barry Dixon  
Title: Authorized Signatory  
Date:

**Cheniere LNG Holdings, LLC**

By:           /s/ Graham McArthur            
Name: Graham McArthur  
Title: Treasurer  
Date: December 23, 2005

**AGREEMENT**

**For**

**ENGINEERING, PROCUREMENT, AND  
CONSTRUCTION SERVICES**

**for**

**42 - INCH SABINE PASS PIPELINE PROJECT**

**between**

**CHENIERE SABINE PASS PIPELINE COMPANY**

**and**

**WILLBROS ENGINEERS, INC.**

---

**AGREEMENT**

**THIS AGREEMENT** for Engineering, Procurement and Construction Services (the “Agreement”) is made and entered into effective as of this 1st day of February 2006 (“Effective Date”) by and between Cheniere Sabine Pass Pipeline Company, a company organized under the laws of the State of Delaware (“Cheniere”), and Willbros Engineers, Inc., a company incorporated under the laws of the State of Delaware (“Willbros”). Cheniere and Willbros are hereinafter sometimes referred to individually as a “Party” or collectively as the “Parties.”

**WHEREAS**, Cheniere desires to design, build, own and operate the 16.0-mile, 42-inch pipeline and related facilities to be constructed from the Cheniere liquefied natural gas terminal to a pipeline interconnect at Johnson’s Bayou, all located entirely in Cameron Parish, Louisiana (as more fully described herein, the “Project”); and

**WHEREAS**, Willbros, itself or through its Subcontractors or Vendors desires to provide engineering, procurement and construction services related to the Project;

**NOW, THEREFORE**, in consideration of the mutual covenants herein and for other good and valuable consideration, the receipt and sufficiency of which are acknowledged, Cheniere and Willbros hereby agree as follows:

**1. SCOPE OF WORK**

- 1.1 In close cooperation and coordination with Cheniere and subject to Paragraph 1.3 below, Willbros agrees to perform the Work, including all Project management, engineering, procurement, construction and construction management for the Project, and provide all equipment, materials, supplies, labor workmanship, apparatus, machinery, tools, structures, inspection, manufacture, fabrication, installation, design, delivery, transportation, storage and any incidental work reasonably inferable as required and necessary to complete the Project in accordance with Applicable Law, Applicable Codes and Standards and all other provisions of this Agreement. Without limiting the generality of the foregoing, the Work is described in more particular detail in the Scope of Work set forth in Schedule “B”.
- 1.2 The Scope of Work is based upon and shall comply with the preliminary engineering developed by Cheniere’s other consultants and contractors and the FERC Certificate.
- 1.3 Willbros shall not be responsible for and the Work excludes the Cheniere Provided Items identified in Paragraph 5.3 which are to be provided by Cheniere.

**2. PROJECT SCHEDULE**

The Work shall be performed in accordance with the dates set forth in the Project Schedule attached as Schedule “F”.

### 3. COMPENSATION

Willbros will submit invoices, and Cheniere shall pay Willbros the amounts due in accordance with Paragraph 5.4 of Schedule "A". The sum of the Cost of the Work, the Willbros Management Fee and the Contingency Costs is guaranteed by Willbros not to exceed Sixty-Seven Million Six Hundred Seventy Thousand Two Hundred Dollars (\$67,670,200), subject to additions and deductions by Change Order as provided herein (the "Guaranteed Maximum Price"), excluding Louisiana sales and use taxes applicable to permanent materials and equipment to be incorporated into the Project, which shall be reimbursed by Cheniere in accordance with Paragraph 5.4.2 of Schedule "A". Costs which would cause the Guaranteed Maximum Price to be exceeded shall be paid by Willbros without reimbursement by Cheniere.

### 4. GENERAL

- 4.1 The Agreement consists of this signed document (the "Signature Document") and the following attached Schedules, which by this reference are incorporated herein and made a part hereof:
- Schedule "A" - Terms and Conditions
    - Attachment I - Willbros Parent Guarantee
    - Attachment II - Payment Bond, Performance Bond and Riders
    - Attachment III - Mechanical Completion Certificate
    - Attachment IV - Project Completion Certificate
    - Attachment V - Start-up Certificate
    - Attachment VI - Change Order Form
    - Attachment VII - Approved Subcontractors and Vendors List
    - Attachment VIII - Organizational Chart
    - Attachment IX - Cheniere's Health, Safety and Environmental Policies
    - Attachment X - Lien and Claim Waivers
  - Schedule "B" - Scope of Work for the Project
    - Attachment I - Work Site
  - Schedule "C" - *Intentionally Omitted*
  - Schedule "D" - Applicable Codes and Standards, Drawings and Specifications
    - Attachment I - Drawings
    - Attachment II - Specifications
  - Schedule "E" - *Intentionally Omitted*
  - Schedule "F" - Project Schedule
- 4.2 A reference in the Agreement to any of the Schedules shall, in addition, be considered a reference to any Attachments to said Schedules, and to all documents referred to in said Schedules or Attachments.
- 4.3 Any notice, demand, offer or other written instrument required or permitted to be given pursuant to this Agreement shall be in writing and signed by the Party giving such notice

and shall be sufficient when delivered in person or sent by e-mail, by facsimile, or by certified or registered mail, to the other Party at the appropriate address as follows:

If delivered to Cheniere:

Richard E. Keyser  
Cheniere Sabine Pass Pipeline  
717 Texas Avenue, Suite 3100  
Houston, Texas 77002  
Telephone: (832) 204-2284  
Fax: (713) 659-5459  
Attention: Mr. Richard E. Keyser  
E Mail: rkeyser@cheniere.com

If delivered to Willbros:

Willbros Engineers, Inc.  
2087 East 71st Street  
P.O. Box 701650  
Tulsa, Oklahoma 74170  
Telephone: (918) 481-4163  
Fax: (918) 493-3430  
Attention: Mr. Curtis E. Simkin  
E Mail: curt.simkin@willbros.com

Copy to:

Allan Bartz  
Cheniere Sabine Pass Pipeline  
717 Texas Avenue, Suite 3100  
Houston, Texas 77002  
Telephone: (713) 659-1361  
Fax: (713) 659-5459  
Attention: Mr. Allan Bartz  
E Mail: abartz@cheniere.com

Copy to:

Willbros Engineers, Inc  
2087 East 71st Street  
P.O. Box 701650  
Tulsa, Oklahoma 74170  
Telephone: (918) 499-3706  
Fax: (918) 499-3702  
Attention: Mr. Mike Reifel  
E Mail: mike.reifel@willbros.com

Willbros or Cheniere may notify the other at any time of a change in, or addition to, the addresses and/or persons to which communications should be sent. Notices, demands, offers or other written instruments shall be deemed to have been duly given on the date actually received by its intended recipient.

**IN WITNESS WHEREOF**, Cheniere and Willbros have executed duplicate originals of the Agreement, effective and binding as of the Effective Date.

Witness

/s/ Richard Keyser

Cheniere Sabine Pass Pipeline Company

By: /s/ Robert Keith Teague

Title: President

Date: February 21, 2006

Witness

/s/ Kevin R. Fox

Willbros Engineers, Inc.

By: /s/ Curtis E. Simpkin

Title: President

Date: February 1, 2006

**SCHEDULE "A"**

**TERMS AND CONDITIONS**

**TABLE OF CONTENTS**

1. DEFINITIONS	A-2
2. WILLBROS' OBLIGATIONS	A-9
3. WILLBROS PERSONNEL AND EQUIPMENT	A-12
4. WORK SITE RESPONSIBILITIES	A-14
5. CHENIERE'S OBLIGATIONS	A-15
6. WORK PLAN AND REPORTS	A-20
7. INSPECTION AND TESTING	A-22
8. COMPLETION AND START-UP	A-23
9. CHANGES	A-25
10. INDEMNITY, LIENS AND PATENTS	A-26
11. INSURANCE	A-30
12. WARRANTY	A-34
13. TITLE TO THE WORK AND TO WORK PRODUCT, CONFIDENTIAL INFORMATION	A-37
14. DISPUTE RESOLUTION	A-40
15. SUSPENSION OF WORK	A-42
16. TERMINATION AT CHENIERE'S CONVENIENCE	A-43
17. TERMINATION BY CHENIERE FOR CAUSE	A-44
18. TERMINATION BY WILLBROS	A-45
19. WILLBROS' OBLIGATIONS UPON SUSPENSION OR TERMINATION	A-45
20. FORCE MAJEURE AND CHENIERE-CAUSED DELAY	A-46
21. LIQUIDATED DAMAGES	A-48
22. PUBLICITY RELEASES	A-49
23. GOVERNING LAW	A-49
24. GENERAL PROVISIONS	A-49
ATTACHMENT I	- WILLBROS PARENT GUARANTEE
ATTACHMENT II	- PAYMENT BOND, PERFORMANCE BOND AND RIDERS
ATTACHMENT III	- MECHANICAL COMPLETION CERTIFICATE
ATTACHMENT IV	- PROJECT COMPLETION CERTIFICATE
ATTACHMENT V	- START-UP CERTIFICATE
ATTACHMENT VI	- CHANGE ORDER FORM
ATTACHMENT VII	- APPROVED SUBCONTRACTORS AND VENDORS LIST
ATTACHMENT VIII	- ORGANIZATIONAL CHART
ATTACHMENT IX	- CHENIERE'S HEALTH, SAFETY AND ENVIRONMENTAL POLICIES
ATTACHMENT X	- LIEN AND CLAIM WAIVERS

---

**SCHEDULE "A"**

**TERMS AND CONDITIONS**

**1. DEFINITIONS**

The following terms shall have the meanings indicated for all purposes of the Agreement and the use of the singular includes the plural, and vice versa:

- 1.1 "AAA" has the meaning set forth in Paragraph 14.3.
- 1.2 "AAA Rules" has the meaning set forth in Paragraph 14.3.
- 1.3 "Actual Contract Amount" has the meaning set forth in Attachment I of the Letter Agreement.
- 1.4 "Agreement" has the meaning set forth in, and incorporates by reference the documents as stated in, Paragraph 4.1 of the Signature Document.
- 1.5 "Amendment" means any written modification of the Agreement, signed by both Cheniere and Willbros, other than Change Orders.
- 1.6 "Applicable Codes and Standards" means any and all codes, standards or requirements set forth herein (including Schedule "D") or in any Applicable Law, which codes, standards and requirements shall govern Willbros' performance of the Work, as provided herein. In the event of an inconsistency or conflict between any of the Applicable Codes and Standards, the highest performance standard as contemplated therein shall govern Willbros' performance.
- 1.7 "Applicable Law" means all laws, statutes, ordinances, certifications, orders, decrees, injunctions, permits, agreements, rules and regulations, including any conditions thereto, of any Governing Authority having jurisdiction over all or any portion of the Work Site or the Project or performance of all or any portion of the Work, or other legislative or administrative action of a Governing Authority, or a final decree, judgment or order of a court which relates to the performance of Work hereunder or the interpretation or application of this Agreement, including (a) any and all permits, authorizations, certifications, or other approvals or orders, (b) any Applicable Codes and Standards set forth in Applicable Law and (c) any Applicable Law related to (i) conservation, regulation, improvement, protection, pollution, contamination or remediation of the environment or (ii) Hazardous Substances or any handling, treatment, storage, release, use and disposal or other disposition of Hazardous Substances, including the Comprehensive Environmental Response, Compensation and Liability Act ("CERCLA").
- 1.8 "Books and Records" has the meaning set forth in Paragraph 2.9.

- 
- 1.9 “Catastrophic Storms” means storms which are listed by the National Oceanic and Atmospheric Administration as Billion Dollar U.S. Weather Disasters.
- 1.10 “Change” means an addition, deletion, suspension of, revision or any other modification or Amendment to the Work. Adjustment to the Guaranteed Maximum Price, the Preparation and Material Receipt Commencement Date, the Construction Commencement Date or the Scheduled Mechanical Completion Date shall in every instance constitute a Change.
- 1.11 “Change Order” means a document, in the form attached hereto as Attachment VI and signed by Cheniere and Willbros, issued on or after the Effective Date, authorizing a Change to the Work, the Guaranteed Maximum Price, the Preparation and Material Receipt Commencement Date, the Scheduled Mechanical Completion Date, the Construction Commencement Date or any other material requirement under this Agreement.
- 1.12 “Cheniere” has the meaning set forth in the introductory paragraph of the Signature Document.
- 1.13 “Cheniere’s Authorized Representative” means Richard E. Keyser, the person hereby authorized by Cheniere to act on its behalf on all matters pertaining to the Agreement, and whose actions shall be binding upon Cheniere.
- 1.14 “Cheniere’s Confidential Information” has the meaning set forth in Paragraph 13.6.
- 1.15 “Cheniere Group” means the owners and affiliated companies of Cheniere or its lenders, including, their respective officers, directors, employees, agents, representatives, contractors (excluding Willbros, its affiliates, Subcontractors and Vendors) and subcontractors.
- 1.16 “Cheniere Provided Items” means those items to be provided by Cheniere, and those responsibilities to be performed by Cheniere, as described in Paragraph 5.3.
- 1.17 “Claim” has the meaning set forth in Paragraph 10.1.1.
- 1.18 “Confidential Information” has the meaning set forth in Paragraph 13.8.
- 1.19 “Construction Commencement Date” means the date set forth in Paragraph 6.1.2.
- 1.20 “Contingency Costs” means those reasonable costs actually incurred incident to the performance of Work under this Agreement and prior to Project Completion of the Project, which are not reimbursable as a Cost of the Work, are not attributable to Willbros’ negligence, willful misconduct or breach of this Agreement, are not recoverable from Subcontractors, Vendors or insurers, and for which records required hereunder exist and are contemporaneously prepared and maintained (“Contingency Costs”).



- 
- 1.21 “Contingency Pool” has the meaning set forth in Attachment I of the Letter Agreement.
- 1.22 “Contract Amount” has the meaning set forth in Paragraph 5.4.1.
- 1.23 “Corrective Work” has the meaning set forth in Paragraph 12.2.2.
- 1.24 “Cost of the Work” has the meaning set forth in Paragraph 5.4.1.
- 1.25 “Defect” or “Defective” has the meaning set forth in Paragraph 12.1.
- 1.26 “Defect Correction Period” has the meaning set forth in Paragraph 12.2.2.
- 1.27 “Disclosing Party” has the meaning set forth in Paragraph 13.8.
- 1.28 “Dispute” has the meaning set forth in Paragraph 14.2.
- 1.29 “Dispute Notice” has the meaning set forth in Paragraph 14.2.
- 1.30 “Drawings” means drawings developed by Willbros and approved by Cheniere for the performance of the Project in accordance with Paragraph 2.7, Paragraph 2.8 and Schedule “B” and as listed in Schedule “D”. The Drawings shall be based on the Specifications. Should there be an inconsistency between the Specifications and the Drawings, the Specifications shall prevail.
- 1.31 “E&O Insurance” has the meaning set forth in Paragraph 11.1.7.
- 1.32 “Effective Date” shall be the date given in the introductory paragraph of the Signature Document.
- 1.33 “Exception Items” means finishing items required to complete various portions of the Work which are incomplete, Defective or otherwise not in accordance with the Agreement, but the completion of which shall not affect, interrupt, disrupt, or interfere with the safe and orderly operation of all or a part of the Project as more fully described in Paragraph 8.
- 1.34 “FERC Certificate” means that certification issued by the Federal Energy Regulatory Commission (“FERC”) (i) authorizing the construction of the Project, including any conditions governing the conduct of the construction activities for the Project, and (ii) detailing the pipeline route and required pipe class associated with the route’s population density survey. The FERC Certificate includes related FERC filing documents CP04-38-00, CP04-38-001, CP04-39-000 and CP04-40-000 and the approved implementation plan.
- 1.35 “Force Majeure” means Catastrophic Storms or floods, lightning, tornadoes, hurricanes, named tropical storms, earthquakes and other acts of God, wars, civil disturbances, terrorist attacks, revolts, insurrections, sabotage, commercial embargoes, epidemics, fires,

explosions, and actions of a Governing Authority that were not requested, promoted, or caused by the affected Party, and strikes or other similar labor actions (except as set forth in (iii) below); provided that such act or event (a) renders impossible or impracticable the affected Party's performance of its obligations under the Agreement, (b) is beyond the reasonable control of the affected Party and not due to its fault or negligence and (c) could not have been prevented or avoided by the affected Party through the exercise of due diligence, including the expenditure of any reasonable sum taking into account the Guaranteed Maximum Price. For avoidance of doubt, Force Majeure shall not include any of the following: (i) a Party's economic hardship, (ii) changes in market conditions, (iii) strikes, or other similar labor actions to the extent caused by the act or omission of the Party claiming Force Majeure, (iv) unavailability of Subcontractors or Vendors; (v) climatic conditions (including rain, snow, wind, temperature and other weather conditions), tides, and seasons, regardless of the magnitude, severity, duration or frequency of such climatic conditions (except those Catastrophic Storms as set forth above), or (vi) nonperformance or delay by Willbros or its Subcontractors or Vendors, unless any of the foregoing conditions is otherwise caused by Force Majeure.

- 1.36 "Guaranteed Maximum Price" shall have the meaning set forth in Paragraph 3 of the Signature Document.
- 1.37 "Governing Authority" means any federal, state, or local department, office, instrumentality, agency, board or commission having jurisdiction over a Party or any portion of the Work, the Work Site or the Project.
- 1.38 "Hazardous Substance" means any substance that under Applicable Law is considered to be hazardous or toxic or is or may be required to be remediated, including (a) "hazardous substances" as defined in 42 U.S.C. § 9601(14), (b) "chemicals" subject to regulation under Title III of the Superfunds Amendments and Reauthorization Act ("SARA") of 1986, (c) natural gas liquids, liquefied natural gas or synthetic gas, (d) any petroleum, petroleum-based products or crude oil or any fraction, or (e) any other chemical, waste, material, pollutant, contaminant or any other substance, exposure to which is now or hereafter prohibited, limited or regulated by any Governing Authority or which may be the subject of liability for damages, costs or remediation.
- 1.39 "Key Personnel" or "Key Persons" has the meaning set forth in Paragraph 3.1 and includes the Willbros Personnel listed in Attachment VIII.
- 1.40 "Letter Agreement" means that letter agreement entered into between the Parties simultaneously with this Agreement dated February 01, 2006.
- 1.41 "Liquidated Damages" has the meaning set forth in Paragraph 21.1.
- 1.42 "Major Vendor" means any Vendor (a) who has entered a subcontract or purchase order having an aggregate value in excess of One Hundred Thousand Dollars (\$100,000), or (b)

---

who has entered multiple subcontracts or purchase orders with an aggregate value in excess of One Hundred Thousand Dollars (\$100,000).

- 1.43 “Mechanical Completion” or “Mechanically Complete” means that all of the following has occurred: (a) the Work is approved by Cheniere as being ready for pre-commissioning and/or commissioning; (b) Willbros has delivered to Cheniere a set of original test and inspection certificates, including hydrostatic test reports, materials documentation, MAOP establishment records, and internal geometry pig results; (c) Willbros has completed all construction, procurement, fabrication, assembly, erection, installation and testing, including final pipeline hydrostatic tests for the pipeline and all appropriate appurtenances to ensure that such systems were correctly constructed, procured, fabricated, assembled, erected, installed and tested and are capable of being operated safely and reliably within the requirements contained in this Agreement; (d) Willbros has delivered to Cheniere a Mechanical Completion Certificate for the Project in the form of Attachment III, and Cheniere has accepted such certificate by signing such certificate; (e) Willbros has dewatered and dried the pipeline to a dewpoint of negative forty degrees Fahrenheit (-40°F); (f) Willbros has completed all Exception Items in accordance with Paragraph 8.1; and (g) Willbros has performed all other obligations required under this Agreement for Mechanical Completion.
- 1.44 “QA/QC Plan” has the meaning set forth in Paragraph 7.1.
- 1.45 “Party” or “Parties” has the meaning set forth in the introductory paragraph of the Signature Document.
- 1.46 “Paragraph” means a paragraph in the Schedule in which it appears, unless otherwise indicated.
- 1.47 “Preparation and Material Receipt Commencement Date” has the meaning set forth in Paragraph 6.1.1.
- 1.48 “Project” means the whole of the Work to be performed by Willbros in respect of the pipeline and in accordance with this Agreement, including the construction, testing, and commissioning of the 16-mile, 42-inch pipeline and related facilities, including an inlet monitor regulator station, a pig launcher, a 30-inch side tap, a 42-inch side tap, two- 42-inch mainline valves, and all other appropriate valves and appurtenances, to be constructed from the Cheniere liquefied natural gas terminal to a pipeline interconnect at Johnson’s Bayou, all located entirely in Cameron Parish, Louisiana; for purposes of clarification, the Project does not include the NGL Meter Station and the Cameron Meadows Meter Station being developed by Cheniere.
- 1.49 “Project Completion” means the date when all Work and all other obligations under this Agreement are fully and completely performed in accordance with the terms of this Agreement, including: (a) the successful achievement of Mechanical Completion of all systems for the Project; (b) the successful achievement of Start-up of all systems for the

- Project; (c) delivery by Willbros of all documentation required to be delivered under this Agreement, including any Work Product, Cheniere's Confidential Information and other documentation; (d) delivery by Willbros to Cheniere of fully executed Final Lien and Claim Waivers in the form of Attachment X – Part 2; (e) removal from the Work Site of all of Willbros Personnel, supplies, waste, materials, rubbish and temporary facilities and restoration of the Work Site to its natural conditions in accordance with this Agreement, Applicable Law and Applicable Codes and Standards or any other requirements of any Governing Authority; (f) delivery by Willbros to Cheniere of a Project Completion Certificate in the form of Attachment IV, which Cheniere has accepted by signing such certificate; (g) delivery by Willbros to Cheniere of evidence acceptable to Cheniere that all Subcontractors and Vendors have been fully and finally paid, including fully executed Final Lien and Claim Waivers from all Subcontractors and Major Vendors in the form of Attachment X – Part 4; (h) Willbros has completed all Exception Items in accordance with Paragraph 8.3; and (i) performance of all other obligations required by this Agreement for Project Completion.
- 1.50 "Project Schedule" means the dates for performance of the Work set forth in Schedule "F", including the Preparation and Material Receipt Commencement Date, the Scheduled Mechanical Completion Date and the Construction Commencement Date.
- 1.51 "Receiving Party" has the meaning set forth in Paragraph 13.8.
- 1.52 "Schedule of Values" has the meaning set forth in Paragraph 5.4.13.
- 1.53 "Scheduled Mechanical Completion Date" means the date set forth in Paragraph 6.1.3.
- 1.54 "Shared Savings" has the meaning set forth in Attachment I of the Letter Agreement.
- 1.55 "Signature Document" means the cover document to which all Schedules of the Agreement are attached thereto and which contains the signature page for which the Parties have signed in order to be bound by this Agreement.
- 1.56 "Specifications" means those items and requirements governing the performance and standards of the Work as set forth in this Agreement, including the FERC Certificate and those standard engineering and construction specifications developed by Willbros in accordance with Paragraph 2 and approved by Cheniere and as set forth or incorporated by reference in Schedule "D".
- 1.57 "Start-up" means that all of the following has occurred: (a) the successful achievement of Mechanical Completion of all systems for the Project; (b) Cheniere has purged the Project with either natural gas or nitrogen with assistance and support from Willbros as requested; (c) delivery by Willbros to Cheniere of a Start-up Certificate in the form of Attachment V, which Cheniere has accepted by signing such certificate; (d) Willbros has completed all Exception Items in accordance with Paragraph 8.2; and (e) performance of all other obligations required by this Agreement for Start-up.

- 
- 1.58 “Subcontractor” means any person or entity (other than a Vendor), of any tier, who performs any portion of the Work or otherwise furnishes labor, materials, supplies or equipment which are a portion of the Work or in connection with the Work and who is not a direct full-time employee of Willbros. The term “Subcontractor” may be referred to throughout the Agreement as if singular in number and means a Subcontractor or an authorized representative of Subcontractor.
- 1.59 “Taxes” has the meaning set forth in Paragraph 5.4.2.
- 1.60 “Vendor” means any person or entity, including a Major Vendor, (other than a Subcontractor), of any tier, including materialmen and equipment suppliers or renters, who, sells or supplies materials, supplies or equipment which are to be incorporated into the Work or used in connection with the Work and who is not a direct full-time employee of Willbros. The term “Vendor” may be referred to throughout the Agreement as if singular in number and means a Vendor or an authorized representative of a Vendor.
- 1.61 “Warranty” has the meaning set forth in Paragraph 12.1.
- 1.62 “Willbros” has the meaning set forth in the introductory paragraph of the Signature Document.
- 1.63 “Willbros Authorized Representative” means Mike Reifel, the person hereby authorized by Willbros to act on its behalf on all matters pertaining to the Agreement, and whose actions shall be binding upon Willbros.
- 1.64 “Willbros’ Confidential Information” has the meaning set forth in Paragraph 13.7.
- 1.65 “Willbros Equipment” means all machinery, apparatus, equipment, materials, tools, temporary facilities and other items previously owned by Willbros or rented for the purposes of this Project and utilized by Willbros to perform the Work but not forming a part of the Project, including also that of its Subcontractors and Vendors at whatever tier.
- 1.66 “Willbros’ Intellectual Property” has the meaning set forth in Paragraph 13.4.
- 1.67 “Willbros Management Fee” means Willbros’ lump sum fee for overhead, profit and indirect job risk which is set forth in the Schedule of Values.
- 1.68 “Willbros Personnel” means all labor, supervisory and other personnel utilized by Willbros to perform the Work, including also those of its Subcontractors and Vendors at whatever tier.
- 1.69 “Willbros Group” means the owners and affiliated companies of Willbros Engineers, Inc., and their respective officers, directors, employees, agents, representatives, Subcontractors, and Vendors.

- 1.70 “Willbros RPI, Inc.” means the Willbros Group affiliated construction company headquartered in Houston, Texas that may be a Subcontractor to Willbros Engineers, Inc. on this Project.
- 1.71 “Work” means all the work, services, duties, responsibilities and other undertakings to be performed by Willbros, its Subcontractors or its Vendors as described in this Agreement, including that set forth in Schedule “B” and Paragraphs 2, 3 and 4.
- 1.72 “Work Plan” means the plan described in Paragraph 6.2 and formulated pursuant to Schedule “B” and Schedule “F” of the Agreement.
- 1.73 “Work Product” has the meaning set forth in Paragraph 13.3.
- 1.74 “Work Site” means the location on which the Project shall be located which is identified in more detail in Attachment I of Schedule “B”.

## **2. WILLBROS’ OBLIGATIONS**

Subject to Paragraph 5 and in close cooperation and coordination with Cheniere, and subject to the terms and conditions of the Agreement, Willbros shall perform the Work in accordance with good engineering and construction practices, Applicable Law, Applicable Codes and Standards, the Specifications and all other provisions of this Agreement. Willbros accepts the relationship of trust and confidence established by this Agreement and covenants with Cheniere to exercise its skill and judgment in furthering the interests of Cheniere. Without limiting the generality of the foregoing or the requirements of any other provisions of this Agreement, Willbros shall:

- 2.1 Engineering, Procurement and Construction Management: Perform the Project management, engineering, procurement, construction and construction management for the Project as described in this Agreement, including in detail at Schedule “B” and the Specifications set forth in Schedule “D”;
- 2.2 Manpower and Equipment: Provide Willbros Equipment and Willbros Personnel, including Subcontractors and Vendors, as set forth in more detail in Paragraph 3;
- 2.3 Compliance: Perform the Work in compliance with the requirements of and provide assistance and documentation to Cheniere as reasonably requested by Cheniere in connection with those approvals, permits, licenses, and/or other authorizations obtained by Cheniere in accordance with Paragraph 5.1;
- 2.4 Health, Safety and Environmental Performance: Perform the Work in a safe, physically secure and environmentally sound manner and otherwise in compliance with Cheniere’s health, safety and environmental policies, which are attached hereto as Attachment IX. Cheniere’s provision of such health, safety and environmental policies shall not in any

- way relieve Willbros of its responsibility regarding safety, health or the environment, and Cheniere, in providing such policies, assumes no liability for the policies;
- 2.5 Authorized Representative: Appoint one (1) or more Willbros Authorized Representative for the duration of the Work;
- 2.6 Timeliness and Manner of Performance: Perform all Work in a timely, complete and workmanlike manner in accordance with this Agreement;
- 2.7 Drawings and Specifications: Prepare, for Cheniere's review and approval in accordance with Paragraph 2.8, all necessary Drawings and Specifications for the Project in accordance with the Applicable Codes and Standards, Applicable Law, Schedule "B", Schedule "D" and all other requirements within this Agreement; and
- 2.8 Review and Approval of Drawings and Specifications:
- 2.8.1 Over the Shoulder Review: During the development of the Drawings and Specifications, provide Cheniere with the opportunity to perform "over-the-shoulder" reviews of the design and engineering in progress. Such reviews may be conducted at Willbros' office located in Tulsa, Oklahoma, at any of its Subcontractors' offices or remotely by electronic internet access. The reviews may be of progress prints, computer images, draft documents, working calculations, draft specifications or reports, Drawings, Specifications or other design documents determined by Cheniere.
- 2.8.2 Submission by Willbros: Submit copies of the Drawings and Specifications to Cheniere for formal review, comment, disapproval and approval in accordance with this Paragraph 2.
- 2.8.3 Review Periods and Cheniere's Approval: Allow Cheniere up to fifteen (15) days from Cheniere's receipt of the Drawings and Specifications submitted in accordance with Paragraph 2.8.2 to issue written comments, proposed changes and/or written approvals or disapprovals of the submission of such Drawings and Specifications to Cheniere.
- (i) If Cheniere does not issue any comments, proposed changes or written approvals or disapprovals within such time period, Willbros may proceed with the development of such Drawings and Specifications and any construction or procurement relating thereto, but Cheniere's lack of comments, approval or disapproval shall in no event constitute an approval of the matters received by Cheniere.
- (ii) In the event that Cheniere disapproves the Drawings or Specifications, Cheniere shall provide Willbros with a written statement of the reasons for such rejection within the time period required for Cheniere's response for

---

disapproval of the Drawings or Specifications. Willbros shall provide Cheniere with revised and corrected Drawings or Specifications as soon as possible thereafter and Cheniere's rights with respect to the issuing of comments, proposed changes or approvals or disapprovals of such revised and corrected Drawings or Specifications are governed by the procedures specified in this Paragraph 2.8.3; provided that Willbros shall not be entitled to any extensions of time to the Project Schedule, the Preparation and Material Receipt Commencement Date, the Construction Commencement Date, the Scheduled Mechanical Completion Date, or an adjustment to the Guaranteed Maximum Price.

- (iii) Upon Cheniere's written approval of the Drawings and Specifications, such Drawings and Specifications shall be the Drawings and Specifications that Willbros shall use to construct the Work; provided that Cheniere's review or approval of any Drawings or Specifications shall not in any way be deemed to limit or in any way alter Willbros' responsibility to perform and complete the Work in strict accordance with the requirements of this Agreement, and in the event that there is a discrepancy, difference or ambiguity between the terms of this Agreement and any Drawings or Specifications, the Agreement shall control. Due to the limited time under this Agreement for Cheniere's review of the Drawings and Specifications, Willbros' or its Subcontractors' or Vendors' expertise in the Work and Cheniere's reliance on Willbros to prepare accurate and complete Drawings and Specifications, Willbros recognizes and agrees that Cheniere is not required or expected to make detailed reviews of the Drawings and Specifications, but instead Cheniere's review of the Drawings or Specifications may be of only a general, cursory nature. Accordingly, any reviews or approvals given by Cheniere under this Agreement with respect to any Drawings or Specifications shall not in any way be, or deemed to be, an approval of any Work or Drawings or Specifications not meeting the requirements of this Agreement, as Willbros has the sole responsibility for performing the Work in accordance with the requirements of this Agreement.

- 2.9 Audit Rights: During the term of this Agreement and for a period of three (3) years after the earlier of Project Completion or termination of this Agreement, retain full and detailed books, construction logs, Drawings, Specifications, Change Orders, records, daily reports, accounts, payroll records, receipts, statements, electronic files (including schedules, e-mails and CAD), correspondence, subcontracts and other documents of Willbros, its affiliated companies or their respective Subcontractors and Vendors, which in any way: (a) pertain to the Agreement, including any such documents related to the Work; or (b) relate to costs, compensation for changes in the Work, or claims of any type by Willbros or its Subcontractors or Vendors ("Books and Records"). Upon five (5) days' written notice, Cheniere or any of its representatives shall have the right to audit such Books and Records during such three (3) year period, provided, however, such parties shall not have the right to audit or have audited Books and Records in connection



---

with the internal composition of any compensation that is fixed in amount hereunder such as the composition of unit rates or hourly rates. When requested by Cheniere, Willbros shall provide the auditors with reasonable access to all such Books and Records, and Willbros Personnel shall cooperate with the auditors to effectuate any audit hereunder. The auditors shall have the right to copy all such Books and Records. Willbros shall include audit provisions identical to this Paragraph 2.9 in all subcontracts and purchase orders with Subcontractors and Vendors. Willbros shall maintain all Books and Records in accordance with generally accepted accounting principles applicable in the United States. Willbros will not charge for any costs incurred by it in assisting Cheniere with audits performed pursuant to this Paragraph 2.9. Willbros obligations under this Paragraph 2.9 shall survive the termination of this Agreement.

### **3. WILLBROS PERSONNEL AND EQUIPMENT**

- 3.1 **Key Personnel:** Willbros Personnel shall be provided in sufficient numbers, and shall be competent and fully qualified to execute the Work. Willbros shall submit to Cheniere's Authorized Representative an updated organization chart of key Project personnel from Willbros' or its Subcontractors' or Vendors' organization ("Key Personnel" or "Key Persons") who shall be assigned to the Work, such organization chart to be in the form of and attached as Attachment VIII. Key Personnel shall, unless otherwise expressly stated in such organization chart, be devoted full-time to the Work for the entire duration of the Project, and Key Personnel shall not be removed or reassigned without Cheniere's prior written approval. Cheniere shall have the right, but not the obligation, at any time to request that Willbros replace any Key Person with another employee acceptable to Cheniere. In such event, Willbros shall replace such Key Person without additional expense to Cheniere.
- 3.2 **Willbros Equipment:** Willbros Equipment shall be suitable for the performance of the Work, in good repair and otherwise comply with the terms of this Agreement. Notwithstanding anything to the contrary contained in this Agreement, Willbros shall be responsible for repair, damage to or destruction or loss of, from any cause whatsoever, all Willbros Equipment. Willbros shall require that all insurance policies (including policies of Willbros and all Subcontractors and Vendors) in any way relating to such Willbros Equipment include clauses stating that each underwriter will waive all rights of recovery, under subrogation or otherwise, against the Cheniere Group.
- 3.3 **Subcontractors and Vendors:** Cheniere acknowledges and agrees that Willbros intends to have portions of the Work accomplished by Subcontractors or Vendors pursuant to written subcontracts or purchase orders between Willbros and such Subcontractors and Vendors, and that such Subcontractors and Vendors may have certain portions of the Work performed by lower tier subcontractors or vendors. All Subcontractors and Vendors shall be reputable, qualified firms with an established record of successful performance in their respective trades performing identical or substantially similar work. All contracts with Subcontractors and Vendors shall be consistent with the terms or provisions of this Agreement. No Subcontractor or Vendor is intended to be or shall be

deemed a third party beneficiary of this Agreement. Willbros shall be fully responsible to Cheniere for the acts or omissions of Subcontractors and Vendors and of persons directly or indirectly employed by either of them, as Willbros is for the acts or omissions of persons directly employed by Willbros. The Work of any Subcontractor or Vendor shall be subject to inspection by Cheniere to the same extent as the Work of Willbros. Nothing contained herein shall (i) create any contractual relationship between any Subcontractor or Vendor and Cheniere, or (ii) obligate Cheniere to pay or cause the payment of any amounts to any Subcontractor or Vendor. Willbros shall, within thirty (30) days prior to the selection of any Subcontractor or Vendor, notify Cheniere in writing of the selection of such Subcontractor or Vendor and inform Cheniere generally what portion of the Work such Subcontractor or Vendor is performing.

- 3.4 Bidding of Subcontracts and Purchase Orders: As part of Willbros' performance of the Work on an "open book basis", Willbros shall provide all necessary services related to the bidding of subcontracts and purchase orders for the construction and procurement components of the Work, including the following: (a) preparing lists of prospective bidders for review by Cheniere; (b) preparing appropriate bid documents, including proposed forms of subcontract and purchase orders; (c) establishing bid schedules; (d) advertising for bids and developing bidder interest; (e) furnishing information concerning the Project to prospective bidders; (f) conducting pre-bid conferences; (g) receiving bids, as described below, and analyzing bids and making recommendations to Cheniere regarding bid awards; (h) investigating the acceptability and responsibility of lower-tiered Subcontractors and Vendors proposed by any Subcontractor or Vendor and advising Cheniere of such evaluations; (i) negotiating with Subcontractors and Vendors concerning any matter related to the Project; and (j) providing such other services required by Cheniere with respect to the bidding process. Willbros shall require bidders to submit their sealed bids directly to Willbros, and Willbros shall forward copies of such bids to Cheniere. Willbros shall require bidders for the construction component of the Work to submit their sealed bids directly to Cheniere and copies of such bids to Willbros. The receipt of the proposed bidders list by Cheniere shall not require Cheniere to investigate the qualifications of prospective bidders, nor shall it waive the right of Cheniere to later object to or reject any proposed Subcontractors or Vendors.

3.5 Cheniere Approval of Subcontractors and Vendors:

- 3.5.1 Approved Subcontractors and Vendors List: Attachment VII sets forth a list of Subcontractors and Vendors that Willbros and Cheniere have agreed are approved Subcontractors and Vendors for the performance of that stated portion of the Work specified in Attachment VII. Approval by Cheniere of any Subcontractors or Vendors does not relieve Willbros of any responsibilities under this Agreement. Unless Cheniere otherwise approves, each prospective bidder list shall contain at least three (3) Subcontractors or Vendors from the Approved Subcontractors and Vendors List in Attachment VII.

- 3.5.2 Additional Proposed Subcontractors and Vendors: In the event that Willbros is considering the selection of a Subcontractor or Vendor not listed on Attachment VII, Willbros shall (i) notify Cheniere of its proposed Subcontractor or Vendor as soon as possible during the selection process, including clearly identifying such proposed Subcontractor or Vendor on the list of prospective bidders provided in accordance with Paragraph 3.4, and furnish to Cheniere all information reasonably requested by Cheniere with respect to Willbros' selection criteria, and (ii) notify Cheniere no less than seven (7) business days prior to the execution of a subcontract or purchase order with a Subcontractor or Vendor not listed on Attachment VII. Cheniere shall have the discretion, not to be unreasonably exercised, to reject any proposed Subcontractor or Vendor not listed on Attachment VII at any time. Willbros shall not enter into any subcontract or purchase order with a proposed Subcontractor or Vendor that is rejected by Cheniere in accordance with the preceding sentence. Cheniere shall undertake in good faith to review the information provided by Willbros with respect to such proposed Subcontractor or Vendor expeditiously and shall notify Willbros of its decision to accept or reject a proposed Subcontractor or Vendor as soon as practicable after such decision is made. Failure of Cheniere to accept a proposed Subcontractor or Vendor within seven (7) business days shall be deemed to be a rejection of such Subcontractor or Vendor.

#### **4. WORK SITE RESPONSIBILITIES**

- 4.1 Land Acquisition Plan: Willbros shall provide reasonable assistance to Cheniere, as requested by Cheniere in writing, in finalizing Cheniere's land acquisition plan as necessary to permit land activities for the Project to proceed in accordance with the FERC Certificate and in accordance with Paragraph 5.2. Such plan may include required rights of way, access roads, materials and equipment storage facilities, office sites, vehicle parking areas, temporary electrical supply locations and trash collection areas, including proposed locations for each.
- 4.2 Provision of Facilities: Willbros shall provide warehousing, offices, storage and related utilities in accordance with the terms of this Agreement and the FERC Certificate for Willbros Equipment and such other materials and equipment to be incorporated into the Work.
- 4.3 Maintenance of Work Sites: Willbros shall, to Cheniere's satisfaction, at all times keep the Work Site free from all waste materials or rubbish caused by the activities of Willbros or any of its Subcontractors or Vendors. Without limitation of the foregoing or limiting Willbros' obligations, Willbros shall clean up all such waste materials or rubbish at Cheniere's request with reasonable notice.
- 4.4 Compliance with Real Property Interests and Other Work Site Restrictions: Willbros shall, in the performance of the Work, comply, and cause all Subcontractors and Vendors to comply, with any agreement governing any easement, lease, right-of-way or other

property interests that affect or govern the Work Site or any other real property used for the purposes of completing the Work, including any line list, insurance or indemnification restrictions or obligations therein, to the extent such easement, lease, right-of-way or other property interests relate to the performance of the Work (but only to the extent that such indemnification restrictions and obligations are consistent with Willbros indemnification obligations agreed to herein). In addition, Willbros shall comply with any one-call requirements imposed by Applicable Law (including local law) and coordinate with owners or operators of all third-party utilities, including those crossed by the Project or otherwise situated within the Work Site or affected by the Work. Cheniere shall provide Willbros with copies of all relevant portions of the agreements governing such easement, lease, right-of-way, and other property interests to the extent that such agreements impose restrictions or obligations on Willbros pursuant to this Paragraph 4.4. To the extent that such agreements require Willbros to procure insurance in addition to or in amounts in excess of that insurance required by this Agreement, the Willbros shall be entitled a Change Order increasing the Guaranteed Maximum Price to cover the cost of such additional insurance.

- 4.5 Coordination of Work: Willbros acknowledges that Cheniere and other consultants and contractors may be working at the Work Site during the performance of this Agreement and the Work or use of certain facilities may be interfered with as a result of such concurrent activities, and Willbros agrees to coordinate the performance of the Work with Cheniere and such other consultants and contractors performing work at the Work Site so as not to materially interfere with Cheniere or its other consultants or subcontractors performing work at the Work Site.

#### **5. CHENIERE'S OBLIGATIONS**

In close cooperation and coordination with Willbros, and subject to the terms and conditions of the Agreement, Cheniere shall:

- 5.1 Licenses and Permits: Provide, or cause to be provided, all approvals, permits, licenses (other than Willbros' or its Subcontractors' or Vendors' operating and professional licenses, including road bonding) and/or other authorizations necessary for the Project from any Governing Authority, including the FERC Certificate and all environmental agencies.
- 5.2 Work Site Access: Secure legal and reasonable access to the Work Site, in accordance with the FERC Certificate, as necessary to permit Willbros to commence Work in accordance with this Agreement by obtaining the rights of way, pipe yards, ware yards, and all other land rights or property interests necessary for the Work, all in accordance with Cheniere's land acquisition plan.
- 5.3 Cheniere Provided Items: Cheniere shall provide: (i) hydrostatic test water; (ii) natural gas or nitrogen and personnel to determine the achievement of Start-up in accordance with Paragraphs 1.57 and 8.2; and (iii) environmental inspection services during

construction Work. In addition, Cheniere shall provide to Willbros the following preliminary drawings which shall be updated by Willbros in accordance with this Agreement: (y) preliminary drawings submitted to FERC, indicated by drawing numbers CH-5763-D-1103 (Sheets 1 to 6), Rev. 0 and titled "Proposed 42-inch Natural Gas Pipeline, Sabine Pass Pipeline Project, FERC Alignment Sheet," and (z) preliminary alignment drawings, indicated by drawing numbers CH-5763D-1101 to 1115, Rev. 1 and titled "Cheniere, Sabine to Johnson's Bayou, Cameron Parish, Louisiana."

5.4 Payment: Remunerate Willbros as required by the Agreement.

5.4.1 Contract Amount: Subject to additions and deductions by Change Order, Cheniere shall pay Willbros for performance of the Work to be performed by Willbros for the Project as described in this Agreement and Schedule "B", the "Contract Amount" consisting of (i) the Cost of the Work, (ii) the Willbros Management Fee, (iii) Contingency Costs, and (iv) Louisiana sales and use taxes applicable to permanent materials and equipment to be incorporated into the Project. The "Cost of the Work" shall mean those costs necessarily incurred by Willbros in good faith in the proper performance of the Work.

5.4.2 Taxes: The Guaranteed Maximum Price includes any and all taxes, assessments, levies, duties, fees, charges and withholding of any kind or nature whatsoever and howsoever described, including value-added, sales and use taxes (except as indicated herein), gross receipts, license, payroll, environmental, profits, premium, franchise, property, excise, capital stock, import, stamp, transfer, employment, occupation, generation, privilege, utility, regulatory, energy, consumption, lease, filing, recording and activities taxes, levies, duties, fees charges, imposts and withholding, together with any and all penalties, interests and additions thereto in any way related to the Work (collectively, "Taxes"), but not including Louisiana sales and use taxes applicable to permanent materials and equipment to be incorporated into the Project, the cost of which is not subject to the Guaranteed Maximum Price. With each invoice that requests reimbursement for Louisiana sales and use taxes applicable to permanent materials and equipment to be incorporated into the Project, Willbros shall separately list in the invoice such Louisiana sales and use taxes. Subject to the other provisions of this Agreement, Cheniere shall remit to Willbros the payment of such Louisiana sales and use taxes within the time allowed for payment of invoices under this Agreement. Willbros shall be responsible for paying to the applicable Governing Authority all Taxes and Louisiana sales and use taxes applicable to permanent materials and equipment to be incorporated into the Project owed under Applicable Law with respect to the Work. IF AND TO THE EXTENT CHENIERE HAS PAID TO WILLBROS THE APPLICABLE TAXES AND LOUISIANA SALES AND USE TAXES APPLICABLE TO PERMANENT MATERIALS AND EQUIPMENT TO BE INCORPORATED INTO THE PROJECT REQUIRED UNDER THIS PARAGRAPH, WILLBROS SHALL INDEMNIFY, DEFEND AND HOLD HARMLESS THE CHENIERE GROUP FROM AND AGAINST ANY CLAIMS

5.4.3 Invoicing: Willbros shall submit invoices to Cheniere as follows:

- (i) twice per month for Project management, engineering and drafting, procurement services, and construction management services performed during the previous invoicing period. Charges shall be accumulated and invoiced on a rate reimbursable basis reflecting man-hours expended as described in Paragraph 1.2 of Attachment I to the Letter Agreement;
- (ii) for permanent materials as set forth in Paragraph 1.3 of Attachment I to the Letter Agreement;
- (iii) for the construction component of the Work as set forth in Paragraph 1.4 of Attachment I to the Letter Agreement;
- (iv) for the Willbros Management Fee properly allocable to the completed Work. The Willbros Management Fee allocable to the completed Work shall be determined by multiplying the percentage completion of the Work by the total amount of the Willbros Management Fee payable to Willbros for the Project; and
- (v) for Willbros' portion of any Shared Savings upon Project Completion.

5.4.4 Invoice Format: Invoices shall be complete with sufficient detail and itemized to facilitate Cheniere's confirmation and approval. Willbros' invoices shall be in a format and supported by such documentation as required by Cheniere. Without limitation of the foregoing, Willbros shall, with each invoice, submit payrolls, petty cash accounts, receipted invoices or invoices with check vouchers attached, and any other evidence required by Cheniere to demonstrate that cash disbursements already made by Willbros on account of the Cost of the Work equal or exceed (i) progress payments already received by Willbros; less (ii) that portion of those payments attributable to the Willbros Management Fee; plus (iii) payrolls for the period covered by the present invoice. Invoices shall show the percentage of completion of each portion of the Work as of the end of the period covered by the invoice. The percentage of completion shall be the lesser of: (1) the percentage of that portion of the Work which has actually been completed; or (2) the percentage obtained by dividing (a) the expense that has actually been incurred by Willbros on account of that portion of the Work for which Willbros has made or intends to make actual payment prior to the next invoice by (b) the share of the Guaranteed Maximum Price allocated to that portion of the Work in the Schedule of Values.

- 5.4.5 Payment Terms: Cheniere shall pay Willbros all undisputed amounts due hereunder within fifteen (15) days after receipt of a complete and accurate invoice for Work that is satisfactorily completed during that period.
- 5.4.6 Lien and Claim Waivers: Each progress invoice shall be accompanied by a fully executed Willbros' Interim Lien and Claim Waiver in the form of Attachment X – Part 1, a fully executed Interim Lien and Claim Waiver in the form of Attachment X – Part 3 for each Subcontractor and Major Vendor, and such other evidence satisfactory to Cheniere to ensure that all amounts owed in connection with performance of this Agreement, including amounts owed to all Subcontractors and Vendors, have been paid. Waivers of liens and claims, however, will not be required from Subcontractors or Vendors until they have performed Work or furnished materials or equipment, and Willbros, Subcontractors and Major Vendors will be required to submit waivers of liens and claims only if they have performed Work or furnished materials or equipment not covered by a previous waiver. Receipt of all Interim Lien and Claim Waivers under this Paragraph 5.4.6 or all Final Lien and Claim Waivers required to meet the requirements of Paragraph 1.49, as applicable, is a condition precedent to payment of any amounts under an invoice.
- 5.4.7 Final Invoice: Prior to submission of a final invoice, Willbros shall perform an audit to determine the total Cost of the Work for the Project. Such audit shall also take into consideration Contingency Costs expended and the Willbros Management Fee in order to calculate the Actual Contract Amount in accordance with Paragraph 2.2 of Attachment I to the Letter Agreement. Willbros shall provide a copy of such audit report to Cheniere upon submission of Willbros' final invoice. Cheniere's accountants will review and report in writing on Willbros final audit within thirty (30) days after delivery thereof by Willbros. If Cheniere's accountants report the Cost of the Work and Contingency Costs as substantiated by Willbros final audit to be less than claimed by Willbros, and Willbros disagrees with Cheniere's accountants reporting of the Cost of the Work and Contingency Costs, Willbros has the right, within seven (7) days of its receipt of the Cheniere's accountants' report, to submit the Dispute for resolution in accordance with Paragraph 14. If Willbros fails to submit the Dispute within such seven (7) day period, Willbros shall be deemed to have agreed with Cheniere's accountants report on the Cost of the Work and Contingency Costs. Final payment shall not be made until resolution of a Dispute under this Paragraph 5.4.7.
- 5.4.8 Unperformed Obligations: Project Completion and payments made hereunder shall not in any way release Willbros or any surety of Willbros or its Subcontractors from any unperformed obligations of the Agreement, including Warranties, compliance with the Agreement, liabilities for which insurance is required or any other responsibility of Willbros, including the payment of any and

all fines and penalties assessed as a result of Willbros' failure to comply with Applicable Law or Applicable Codes and Standards.

5.4.9 Withholding: In addition to retainage and amounts withheld that are in dispute, Cheniere may, in addition to any other rights at law, in equity or under this Agreement, withhold amounts otherwise due by Cheniere to Willbros without payment of interest on account of: (a) Defective Work not remedied by Willbros in accordance with Paragraph 12; (b) the filing of claims or liens or evidence indicating the probable filing of claims or liens against Cheniere, the Project or the Work; (c) failure of Willbros to pay amounts when due for labor, services or material used by Willbros in performing the Work or amounts due to Subcontractors or Vendors as required in their respective subcontracts and purchase orders; (d) the assessment of any fines or penalties against Cheniere as a result of Willbros' failure to comply with Applicable Law or Applicable Codes and Standards; or (e) any other circumstance permitted under this Agreement. If and when the cause, or causes, for withholding any such payment shall be remedied or removed and satisfactory evidence of such remedy or removal has been presented to Cheniere, the payments withheld shall be made to Willbros in the next invoice and if the final invoice has been paid, within thirty (30) days of such remedy or removal.

5.4.10 Payment Account Number: Payments to Willbros under this Agreement shall be made by wire transfer to:

Southwest Bank of Texas  
Houston, Texas  
ABA#: 113-011-258  
Beneficiary: Willbros USA, Inc.  
Account Number: 127736

5.4.11 Address for Invoicing: Willbros shall submit invoices for payment to:

Cheniere Sabine Pass Pipeline  
717 Texas Avenue, Suite 3100  
Houston, Texas 77002  
Telephone: (713) 659-1361  
E Mail abartz@cheniere.com  
Facsimile: (713) 659-5459  
Attention: Mr. Allan Bartz

Or such other addressee and location as Cheniere may direct in writing.

5.4.12 Payment of Shared Savings: Willbros shall be paid its share of the Shared Savings within thirty (30) days of settlement and verification thereof by the



Parties following Cheniere's receipt of a final invoice and accounting report from Willbros in accordance with Paragraphs 5.4.4 and 5.4.7.

- 5.4.13 Schedule of Values: Attachment IV of the Letter Agreement sets forth the schedule of values allocating the entire Guaranteed Maximum Price among the various portions of the Work as of the Effective Date of the Agreement ("Schedule of Values") to be used as a basis for reviewing the invoices. Willbros shall periodically, upon award of various components of the Work to Subcontractors and Vendors, submit to Cheniere for Cheniere's written approval an updated Schedule of Values allocating the entire Guaranteed Maximum Price among the various portions of the Work, except that the Willbros Management Fee shall be shown as a separate line item. The updated Schedule of Values shall be prepared in such form and supported by such data to substantiate its accuracy as Cheniere may require. Each Cheniere-approved, updated Schedule of Values shall be incorporated into this Agreement by Change Order.

## **6. WORK PLAN AND REPORTS**

- 6.1 Time for Performance: Willbros shall commence performance of the Work upon the Effective Date and shall perform the Work in accordance with the Project Schedule set forth in this Paragraph 6 and in Schedule "F". TIME IS OF THE ESSENCE with respect to Willbros' performance of the Work. Willbros may not commence a portion of the Work prior to the relevant commencement date, if any, listed below:
- 6.1.1 Willbros shall commence Work related to ware yard preparation and material receipt at the Work Site no earlier than January 01, 2007 ("Preparation and Material Receipt Commencement Date"). The Preparation and Material Receipt Commencement Date shall only be adjusted by Change Order as provided under this Agreement.
- 6.1.2 Willbros shall commence Work related to the construction of the Project at the Work Site no earlier than April 01, 2007 ("Construction Commencement Date"). The Construction Commencement Date shall only be adjusted by Change Order as provided under this Agreement.
- 6.1.3 Willbros shall achieve Mechanical Completion of the Project no later than September 30, 2007 ("Scheduled Mechanical Completion Date") based on an April 1, 2007, release for construction. The Scheduled Mechanical Completion Date shall only be adjusted by Change Order as provided under this Agreement.
- 6.2 Work Plan: On or before February 28, 2006, Willbros shall prepare and submit to Cheniere's Authorized Representative for review and written approval, a detailed critical path method schedule in a format approved by Cheniere ("Work Plan"). The Work Plan shall be based on and consistent with the Project Schedule, including the Preparation and Material Receipt Commencement Date, the Construction Commencement Date and the

---

Scheduled Mechanical Completion Date, shall show the method and order in which Willbros shall perform the Work, its subcontracting plan, and any other information that Cheniere may consider useful. The Work Plan shall represent Willbros' best judgment as to how it shall achieve Mechanical Completion by the Scheduled Mechanical Completion Date, and shall be a detailed graphic representation of all significant aspects of the Work showing Willbros' plans for performance of the Work. Without limitation of the foregoing, the Work Plan shall include separate activities for each portion of the Work, show the duration, early/late start dates, early/late finish dates and available float for each activity, show activity number, activity description and responsible Subcontractor or Vendor, and show an uninterrupted critical path from commencement of the Work through Project Completion.

- 6.3 Updated Work Plan: The Work Plan shall be used as the basis for progress reporting, schedule control and schedule forecasting. As reasonably requested by Cheniere, Willbros shall revise the Work Plan to include the effect of Change Orders and Amendments and to reflect actual Work in progress as agreed with Cheniere, provided, however, Willbros may not modify the Preparation and Material Receipt Commencement Date, the Construction Commencement Date or the Scheduled Mechanical Completion Date without a Change Order being executed in accordance with this Agreement. Each updated Work Plan shall provide the same details and form as required of the Work Plan. Willbros shall prepare schedule and cash flow forecasts on a monthly basis or as requested by Cheniere that reasonably predict the date for Mechanical Completion of the Project. Willbros shall notify Cheniere of any anticipated or actual slippage in the performance of the Work as compared to the Work Plan. Willbros shall provide to Cheniere weekly reports, monthly summaries of such reports, and upon request, all other relevant information concerning any circumstance or condition affecting the Work.
- 6.4 Progress Meetings: Work progress meetings between Authorized Representatives shall be held monthly between Cheniere and Willbros.
- 6.5 Recovery: If Willbros is responsible for any delays in the time and/or sequence of the performance of the Work that is on the critical path of the Work Plan, Willbros shall on its own initiative or at Cheniere's written directive, employ such additional forces, obtain such additional equipment, employ such additional supervision, pay such additional overtime wages, and use such priority freight as may be required to bring the Work back on schedule. If Willbros' progress is more than fourteen (14) days behind the critical path of the Work Plan, Cheniere may, without prejudice to any other remedies available to it under this Agreement, also require in writing that Willbros submit, within two (2) days of Cheniere's written notice and for Cheniere's approval, a recovery plan to Cheniere detailing Willbros' proposal for bringing the Work back on schedule and that the sequence of the performance of the Work be changed. In no event shall such costs to bring the Work back on schedule cause the Guaranteed Maximum Price to be exceeded. This Paragraph 6.5 shall not be construed to require that Cheniere give Willbros a written notice to perform any of the acts listed herein, and the Parties agree that Cheniere's

failure to give such written notice to Willbros shall not in any way relieve Willbros of its obligation to perform the Work within the times set forth in the Project Schedule.

- 6.6 Acceleration: Even if the Work is otherwise in compliance with the Work Plan, Cheniere may, at any time, direct Willbros to accelerate the Work by, among other things, establishing additional shifts, paying or authorizing overtime or providing additional equipment. In the event of this directive, Cheniere's sole liability to Willbros shall be to pay Willbros for any documented costs clearly and solely attributable to such acceleration. Such costs may include any shift differential, premium, or overtime payments to workers or field supervisors and other employees of Willbros dedicated to the Work on a full-time basis actually incurred over and above Willbros' normal rates, overtime charges for equipment, amounts to account for lost efficiency of workers and other costs agreed upon by Cheniere and Willbros in writing. Any adjustment to the Guaranteed Maximum Price resulting from Cheniere's directive to accelerate the Work shall be implemented by Change Order.

## **7. INSPECTION AND TESTING**

- 7.1 QA/QC Plan: On or before March 31, 2006, Willbros shall submit to Cheniere's Authorized Representative, for review and written approval thereof, a quality assurance and quality control plan for materials procurement and for construction ("QA/QC Plan"). Cheniere's review and approval of the QA/QC Plan shall in no way relieve Willbros of its responsibility for performing the Work in compliance with this Agreement.
- 7.2 Willbros' Inspection and Testing of Work: Willbros shall inspect and test the overall and component parts of the Work, including that of its Subcontractors or Vendors, to ensure conformity of such Work with Applicable Codes and Standards, and all other obligations within this Agreement.
- 7.3 Cheniere Inspection of Work: All Work shall be subject to inspection by Cheniere or its designee at all times and at Cheniere's own expense, to determine whether the Work conforms to the requirements of this Agreement. Willbros shall furnish Cheniere with access to all locations where Work is in progress, including locations not on the Work Site such as locations from where equipment and material are being obtained, including pipe fabrication and coating and factory testing of mainline valves.
- 7.4 Correction of Work Prior to Start-up: If, in the judgment of Cheniere, any Work is Defective or any Work is determined to be Defective as a result of the testing and inspections performed pursuant to Paragraph 7.2, then Willbros shall, at its own expense, promptly correct such Defective Work, whether by repair, replacement or otherwise. Subject to Willbros' right to pursue a Dispute under Paragraph 14, the decision of Cheniere shall be conclusive as to whether the Work is conforming or Defective, and Willbros shall comply with the instructions of Cheniere in all such matters while pursuing any such Dispute. If it is later determined that the Work was not Defective, then Cheniere shall reimburse Willbros for all costs incurred in connection with such repair or

replacement and a Change Order shall be issued for such amount and shall address any impact the repair or replacement may have had on the Project Schedule. If Willbros fails, after a reasonable period of time not to exceed five (5) days, to repair or replace any Defective Work, or to commence to repair or replace any Defective Work and thereafter continue to proceed diligently to complete the same, then Cheniere may repair or replace such Defective Work and the expense thereof shall be paid by Willbros.

- 7.5 Notice to Cheniere and Cost of Disassembling: Willbros shall advise Cheniere's Authorized Representative of tests to be witnessed sufficiently in advance to enable him or his designee to attend and witness such test at Cheniere's expense. Willbros shall likewise advise Cheniere's Authorized Representative in advance of any critical component of the Work to be closed or covered. If such action is taken by Willbros before an opportunity to inspect or witness has been provided to Cheniere, it must, if required by Cheniere, be opened or uncovered for inspection or witnessing and recovered at Willbros' expense. The cost of disassembling, dismantling or making safe finished Work for the purpose of inspection, other than as set forth above, and reassembling such portions (and any delay associated therewith) shall be borne by Cheniere if such Work is found to conform with the requirements of this Agreement and by Willbros if such Work is found to be Defective.
- 7.6 No Obligation to Inspect: Cheniere's right to conduct inspections under this Paragraph 7 shall not obligate Cheniere to do so. Neither the exercise of Cheniere of any such right, nor any failure on the part of Cheniere to discover or reject Defective Work shall be construed to imply an acceptance of such Defective Work or a waiver of such Defect.

## **8. COMPLETION AND START-UP**

- 8.1 Mechanical Completion: Willbros shall comply with all requirements for Mechanical Completion, including as set forth in the definition of the term Mechanical Completion and elsewhere in this Agreement. When Willbros believes the Work is Mechanically Complete, Willbros shall certify to Cheniere in writing in the form of the Mechanical Completion Certificate attached hereto as Attachment III that all of the requirements for Mechanical Completion of the Work have occurred, including all documentation required to establish that the requirements for Mechanical Completion have been met. Within seven (7) days after receipt of such notice Cheniere shall inspect the Work and either accept the Work as being Mechanically Complete (which acceptance shall be evidenced by Cheniere's signature on such Mechanical Completion Certificate), or specify the Exception Items which must be completed to achieve Mechanical Completion in a written notice to Willbros. Upon completion or correction of such Exception Items, Willbros shall so advise Cheniere. Within seven (7) days after receipt of such notice, Cheniere shall either accept the Work as being Mechanically Complete in the manner set forth above, or notify Willbros in writing of still unfinished or uncorrected Exception Items. If Exception Items remain unfinished or uncorrected, the foregoing procedure shall be repeated until the Work is Mechanically Complete.

- 8.2 Start-up: Willbros shall comply with all requirements needed to achieve Start-up, including as set forth in the definition of the term Start-up and elsewhere in this Agreement. When Willbros believes Start-up has been achieved, Willbros shall certify to Cheniere in writing in the form of the Start-up Certificate attached hereto as Attachment V that all of the requirements for achieving Start-up have occurred, including all documentation required to establish that the requirements for Start-up have been met. Within seven (7) days after receipt of such notice Cheniere shall inspect the Work and either accept the Work as having achieved Start-up (which acceptance shall be evidenced by Cheniere's signature on such Start-up Certificate), or specify the Exception Items which must be completed to achieve Start-up in a written notice to Willbros. Upon completion or correction of such Exception Items, Willbros shall so advise Cheniere. Within seven (7) days after receipt of such notice, Cheniere shall either approve the Start-up of the Work in the manner set forth above, or notify Willbros in writing of still unfinished or uncorrected Exception Items. If Exception Items remain unfinished or uncorrected, the foregoing procedure shall be repeated until Start-up is achieved. Notwithstanding the foregoing, if Cheniere has not commenced the introduction of either natural gas or nitrogen in accordance with Paragraph 1.57 within thirty (30) days of achievement of Mechanical Completion, then Start-up shall be deemed achieved upon the expiration of such thirty (30) day period, provided that Willbros has fully satisfied all other requirements for Start-up.
- 8.3 Project Completion: Willbros shall comply with all requirements for Project Completion, including as set forth in the definition of the term Project Completion and elsewhere in this Agreement. When Willbros believes it has completed all obligations under this Agreement to achieve Project Completion, Willbros shall certify to Cheniere in writing in the form of the Project Completion Certificate as attached hereto as Attachment IV that all of the requirements for achieving Project Completion have occurred, including all documentation required to establish that the requirements of Project Completion have been met. Within seven (7) days after receipt of such notice Cheniere shall inspect the Work and either accept that Project Completion has been achieved (which acceptance shall be evidenced by Cheniere's signature on such Project Completion Certificate), or specify the Exception Items which must be completed to achieve Project Completion in a written notice to Willbros. Upon completion or correction of such Exception Items, Willbros shall so advise Cheniere. Within seven (7) days after receipt of such notice, Cheniere shall either accept the Work as having achieved Project Completion in the manner set forth above, or notify Willbros in writing of still unfinished or uncorrected Exception Items. If Exception Items remain unfinished or uncorrected, the foregoing procedure shall be repeated until Project Completion is achieved.
- 8.4 No Waiver: No acceptance by Cheniere of any or all of the Work or any other obligations of Willbros under this Agreement, including acceptance of Mechanical Completion, Start-up or Project Completion, nor any payment made hereunder, whether an interim or final payment, shall in any way release Willbros or any surety of Willbros or its Subcontractors from any obligations or liability pursuant to this Agreement, including obligations with respect to unperformed obligations of this Agreement, obligations

regarding any remediation or other Work required pursuant to Paragraph 12, correction of any Work that does not conform to the requirements of the Agreement or other Warranty obligations, and any liabilities for which insurance is required or any other responsibility of Willbros, including the payment of any and all fines and penalties assessed as a result of Willbros' failure to comply with Applicable Law.

## 9. CHANGES

- 9.1 Change Orders Requested by Cheniere: At any time upon written notice to Willbros from Cheniere, and without notice to the sureties, if any, Cheniere may advise Willbros to make or agree with Willbros that there has been a Change to the Work, including the time and/or sequence of performance, or the conditions affecting the Work. All Work involved in a Change, as directed by a Change Order, shall be performed in accordance with the terms and conditions of the Agreement and shall not otherwise affect the existing rights or obligations of the Parties (except as may be expressly stated in a Change Order). Cheniere shall specify, in the Change Order, the amount and nature of Work to be done or omitted, the materials to be used and the equipment to be furnished. Willbros shall perform the Work as changed without delay.
- 9.2 Change Order Format: A Change in the Work shall be set forth in writing in a Change Order, using the form provided in Attachment VI, and signed by both Parties. Change Orders shall include the adjustment, if necessary, in the Preparation and Material Receipt Commencement Date, the Scheduled Mechanical Completion Date, Construction Commencement Date or the Guaranteed Maximum Price.
- 9.3 Change Orders Act as Accord and Satisfaction: The Parties agree that Change Orders executed by Cheniere and Willbros shall constitute a full and final settlement and accord and satisfaction of all effects of the Change upon any and all respects of this Agreement and the Work and shall compensate Willbros fully. Willbros expressly waives and releases any and all right to make a claim or demand or to take any action or proceeding for any other consequences arising out of, relating to, or resulting from the Change reflected in the Change Order, whether the consequences result directly or indirectly from the Change reflected in that Change Order.
- 9.4 Adjustment Only Through Change Order: Willbros shall not perform a Change of any kind, except as authorized in a Change Order. Adjustments to the Guaranteed Maximum Price, the Preparation and Material Receipt Commencement Date, the Construction Commencement Date or the Scheduled Mechanical Completion Date shall only be made by Change Order. No course of conduct or dealings between the Parties, nor express or implied acceptance of additions, deletions, suspensions or modifications to this Agreement, the Drawings or the Specifications, including any Work, and no claim that Cheniere has been unjustly enriched by any such addition, deletion, suspension or modification of this Agreement, the Drawings or the Specifications, whether or not there is in fact any such unjust enrichment, shall be the basis for any claim for an adjustment in the Guaranteed Maximum Price, the Preparation and Material Receipt Commencement

Date, the Construction Commencement Date, the Scheduled Mechanical Completion Date or any other obligations of Willbros under this Agreement.

- 9.5 Change Orders Requested by Willbros: Willbros shall give written notice to Cheniere of any requests, claims or proposals for adjustments to the Work, the Guaranteed Maximum Price, the Preparation and Material Receipt Commencement Date, the Construction Commencement Date or the Scheduled Mechanical Completion Date for Changes directed by Cheniere or for circumstances otherwise permitted by this Agreement within the time frame and in accordance with Paragraph 14.1.
- 9.6 Change Order Compensation: The cost or credit to Cheniere resulting from a Change in the Work shall in each instance be determined in accordance with one of more of the following methods and specified in the Change Order: (i) by mutual acceptance of a properly itemized lump sum amount; or (ii) for Project management, engineering and drafting, procurement services and construction management services, by unit prices or hourly rates set forth in Attachment II of the Letter Agreement or otherwise agreed upon by the Parties; or (iii) for construction work performed by Willbros RPI, Inc. (if such entity is the selected construction Subcontractor), by unit prices or hourly rates set forth in Attachment III of the Letter Agreement or otherwise agreed upon by the Parties. If any of the Changes provided for in a Change Order increase the lump sum construction costs within the Guaranteed Maximum Price, such increase shall be subject to Cheniere's right to retainage as set forth in Paragraph 1.4.1 of the Letter Agreement.

#### **10. INDEMNITY, LIENS AND PATENTS**

- 10.1 General Indemnifications: Notwithstanding any other provision to the contrary, Cheniere and Willbros agree as follows:

- 10.1.1 INJURIES TO WILLBROS GROUP PERSONNEL AND DAMAGE TO WILLBROS GROUP PROPERTY: WILLBROS HEREBY RELEASES, AND AGREES TO DEFEND, INDEMNIFY, AND HOLD THE CHENIERE GROUP HARMLESS FROM AND AGAINST, ANY AND ALL CLAIMS, DEMANDS, CAUSES OF ACTION, SUITS, LIABILITIES, LOSSES, DAMAGES AND EXPENSES INCLUDING COURT COSTS AND REASONABLE ATTORNEY'S FEES (COLLECTIVELY, "CLAIMS") ARISING OUT OF OR RESULTING FROM (1) INJURY TO OR DEATH OF THE WILLBROS GROUP PERSONNEL, OR (2) DAMAGE TO OR DESTRUCTION OF THE WILLBROS GROUP PROPERTY, WHETHER OR NOT SUCH CLAIMS ARE DUE TO AN ACT, OMISSION, NEGLIGENCE WHETHER CONTRIBUTORY, JOINT, OR SOLE, FAULT OR STRICT LIABILITY OF THE CHENIERE GROUP, BUT EXCLUDING ONLY THOSE CLAIMS DUE TO THE WILLFUL MISCONDUCT OF THE CHENIERE GROUP.
- 10.1.2 THIRD PARTY INDEMNIFICATION: WILLBROS HEREBY RELEASES, AND AGREES TO DEFEND, INDEMNIFY, AND HOLD CHENIERE GROUP HARMLESS FROM AND AGAINST, ANY AND ALL CLAIMS ARISING OUT OF OR RESULTING FROM DAMAGE TO OR DESTRUCTION OF PROPERTY OR PERSONAL INJURY TO OR DEATH OF ANY THIRD PARTY (OTHER THAN A MEMBER OF THE CHENIERE GROUP OR THE WILLBROS

GROUP) TO THE EXTENT ARISING OUT OF OR RESULTING FROM WILLBROS' OR ITS SUBCONTRACTORS' OR VENDORS' PERFORMANCE OF THE WORK, INCLUDING THE BREACH OF THIS AGREEMENT BY WILLBROS AND THE NEGLIGENCE, GROSS NEGLIGENCE OR WILLFUL MISCONDUCT OF WILLBROS, ITS SUBCONTRACTORS, ITS VENDORS OR ANYONE EMPLOYED BY THEM OR ANYONE FOR WHOSE ACTS THEY MAY BE LIABLE.

- 10.1.3 INJURIES TO CHENIERE GROUP PERSONNEL AND DAMAGE TO CHENIERE GROUP PROPERTY: CHENIERE HEREBY RELEASES, AND AGREES TO DEFEND, INDEMNIFY, AND HOLD THE WILLBROS GROUP HARMLESS FROM AND AGAINST, ANY AND ALL CLAIMS ARISING OUT OF OR RESULTING FROM (1) INJURY TO OR DEATH OF THE CHENIERE GROUP PERSONNEL, OR (2) DAMAGE TO OR DESTRUCTION OF THE CHENIERE GROUP PROPERTY (EXCLUDING THE WORK OR THE PROJECT), WHETHER OR NOT SUCH CLAIMS ARE DUE TO AN ACT, OMISSION, NEGLIGENCE WHETHER CONTRIBUTORY, JOINT, OR SOLE, FAULT OR STRICT LIABILITY OF THE WILLBROS GROUP, BUT EXCLUDING ONLY THOSE CLAIMS DUE TO THE WILLFUL MISCONDUCT OF THE WILLBROS GROUP.
- 10.1.4 HAZARDOUS SUBSTANCES INDEMNIFICATION: WILLBROS HEREBY RELEASES, AND AGREES TO DEFEND, INDEMNIFY AND HOLD CHENIERE GROUP HARMLESS FROM ANY AND ALL CLAIMS, FINES, PENALTIES OR REMEDIATION OBLIGATIONS ARISING OUT OF OR RESULTING FROM (A) ACTUAL OR ALLEGED POLLUTION OR CONTAMINATION OF THE LAND, WATER OR AIR ARISING FROM SPILLS, RELEASES, DISCHARGES OR OTHERWISE OF HAZARDOUS SUBSTANCES, INCLUDING FUELS, LUBRICANTS, MOTOR OILS, PIPE DOPE, PAINTS, SOLVENTS, AND GARBAGE, USED, HANDLED OR DISPOSED OF BY WILLBROS OR ITS SUBCONTRACTORS OR VENDORS DURING THE PERFORMANCE OF THE WORK, AND (B) ANY ENVIRONMENTAL DAMAGE OF ANY OTHER NATURE TO THE EXTENT RESULTING FROM THE PERFORMANCE OF THE WORK BY WILLBROS OR ITS SUBCONTRACTORS OR VENDORS; PROVIDED, HOWEVER, THAT WILLBROS SHALL HAVE NO LIABILITY OR RESPONSIBILITY FOR ANY POLLUTION, CONTAMINATION OR ENVIRONMENTAL DAMAGE EXISTING AT THE WORK SITE PRIOR TO THE COMMENCEMENT OF THE WORK.
- 10.1.5 COMPLIANCE WITH APPLICABLE LAW INDEMNIFICATION: WILLBROS HEREBY RELEASES, AND AGREES TO DEFEND, INDEMNIFY AND HOLD CHENIERE GROUP HARMLESS FROM ANY AND ALL CLAIMS, FINES, PENALTIES OR REMEDIATION OBLIGATIONS TO THE EXTENT ARISING OUT OF OR RESULTING FROM WILLBROS' OR ITS SUBCONTRACTORS' OR VENDORS' ACTUAL OR ALLEGED FAILURE TO COMPLY WITH APPLICABLE LAW OR APPLICABLE CODES AND STANDARDS, OR ANY JUDICIAL ARBITRAL OR REGULATORY INTERPRETATION THEREOF.
- 10.1.6 WAIVER OF CONSEQUENTIAL DAMAGES: NOTWITHSTANDING ANY OTHER PROVISIONS IN THIS AGREEMENT TO THE CONTRARY, IN NO EVENT SHALL ANY ENTITY IN EITHER CHENIERE GROUP OR THE WILLBROS GROUP BE LIABLE, ONE TO THE OTHER, FOR INDIRECT, SPECIAL, INCIDENTAL OR CONSEQUENTIAL DAMAGES,



INCLUDING LOSS OF PROFITS, LOSS OF USE OF ASSETS, OR BUSINESS INTERRUPTION UNDER THIS AGREEMENT OR ANY CAUSE OF ACTION RELATED THERETO, PROVIDED THAT THE LIMITATION OF LIABILITY SET FORTH IN THIS PARAGRAPH 10.1.6 SHALL NOT APPLY TO (A) WILLBROS' CONFIDENTIALITY OBLIGATIONS AS PROVIDED BY THIS AGREEMENT; (B) WILLBROS' INDEMNIFICATION OBLIGATIONS FOR THIRD PARTY CLAIMS UNDER THIS AGREEMENT; (C) THE AMOUNTS ENCOMPASSED WITHIN THE LIQUIDATED DAMAGES PROVIDED FOR IN PARAGRAPH 21; OR (D) AS EXPRESSLY PERMITTED UNDER PARAGRAPH 21.2.

- 10.2 LIEN INDEMNIFICATION: WITHOUT IN ANY WAY LIMITING THE FOREGOING, SO LONG AS CHENIERE REMITS UNDISPUTED PAYMENTS TO WILLBROS WHEN DUE UNDER THIS AGREEMENT, WILLBROS HEREBY RELEASES, AND AGREES TO DEFEND, INDEMNIFY AND HOLD CHENIERE GROUP HARMLESS FROM, AND SHALL KEEP THE WORK, THE WORK SITE AND THE PROJECT FREE AND CLEAR OF, ANY AND ALL LIENS AND ENCUMBRANCES ASSERTED BY AN ENTITY ACTING THROUGH WILLBROS, ANY SUBCONTRACTOR, ANY VENDOR OR ANY OTHER PERSON OR ENTITY ACTING THROUGH OR UNDER ANY OF THEM. IF WILLBROS FAILS TO DISCHARGE SUCH LIEN OR ENCUMBRANCE OR POST ADEQUATE SECURITY WITH RESPECT THERETO WITHIN THIRTY (30) DAYS OF THE FILING OF SUCH LIEN OR ENCUMBRANCE, CHENIERE, IF IT SO ELECTS, MAY DISCHARGE ANY SUCH LIENS OR ENCUMBRANCES, AND WILLBROS SHALL BE LIABLE TO CHENIERE FOR ALL DAMAGES, COSTS, LOSSES, AND EXPENSES (INCLUDING ALL ATTORNEYS' FEES, CONSULTANT FEES AND LITIGATION OR ARBITRATION EXPENSES) INCURRED BY CHENIERE ARISING OUT OF OR RELATING TO SUCH DISCHARGE OR RELEASE. THEREAFTER, CHENIERE MAY INVOICE WILLBROS FOR SUCH AMOUNT OWED (WHICH INVOICE SHALL BE PAID BY WILLBROS WITHIN THIRTY (30) DAYS AFTER RECEIPT THEREOF) OR DEDUCT THE AMOUNT SO PAID BY CHENIERE FROM SUMS DUE OR WHICH THEREAFTER BECOME DUE TO WILLBROS HEREUNDER.
- 10.3 PATENT AND COPYRIGHT INDEMNIFICATION: WILLBROS HEREBY RELEASES, AND AGREES TO DEFEND, INDEMNIFY AND HOLD CHENIERE GROUP HARMLESS FROM ANY CLAIMS TO THE EXTENT ARISING FROM OR RELATING TO THE ACTUAL OR ALLEGED INFRINGEMENT OF ANY DOMESTIC OR FOREIGN PATENTS, COPYRIGHTS, TRADEMARKS OR OTHER INTELLECTUAL PROPERTY RIGHTS THAT MAY BE ATTRIBUTABLE TO WILLBROS OR ITS SUBCONTRACTORS OR VENDORS IN CONNECTION WITH THE WORK. IN THE EVENT THAT ANY SUIT, CLAIM, TEMPORARY RESTRAINING ORDER OR PRELIMINARY INJUNCTION IS GRANTED IN CONNECTION WITH THIS PARAGRAPH 10.3, WILLBROS SHALL, IN ADDITION TO ITS OBLIGATION ABOVE, MAKE EVERY REASONABLE EFFORT, BY GIVING A SATISFACTORY BOND OR OTHERWISE, TO SECURE THE SUSPENSION OF THE INJUNCTION OR RESTRAINING ORDER. IF, IN ANY SUCH SUIT OR CLAIM, THE WORK, THE PROJECT OR ANY PART, COMBINATION OR PROCESS THEREOF, IS HELD TO CONSTITUTE AN INFRINGEMENT AND ITS USE IS PRELIMINARILY OR PERMANENTLY ENJOINED, WILLBROS SHALL PROMPTLY MAKE EVERY REASONABLE EFFORT TO SECURE FOR CHENIERE A LICENSE, AT NO COST TO CHENIERE, AUTHORIZING CONTINUED USE OF THE INFRINGING WORK. IF WILLBROS IS UNABLE TO SECURE SUCH A LICENSE WITHIN A REASONABLE TIME, WILLBROS SHALL, AT ITS OWN EXPENSE AND WITHOUT IMPAIRING PERFORMANCE REQUIREMENTS, EITHER REPLACE THE

AFFECTED WORK, IN WHOLE OR PART, WITH NON-INFRINGEMENT COMPONENTS OR PARTS OR MODIFY THE SAME SO THAT THEY BECOME NON-INFRINGEMENT.

10.4 ATTORNEYS' FEES: EACH PARTY AGREES TO REIMBURSE THE PREVAILING PARTY FOR ANY AND ALL NECESSARY EXPENSES, ATTORNEY'S FEES, AND RELATED COSTS INCURRED IN THE ENFORCEMENT OF ANY PART OF THE INDEMNITY AGREEMENTS PROVIDED FOR HEREIN.

10.5 Enforceability:

- 10.5.1 Exclusions to Liability and Indemnity: Except as expressly provided elsewhere in this Agreement, the exclusions of liability and indemnities herein shall apply according to their terms to any such Claim, loss, damage, expense, injury, illness or death, without regard to the cause thereof, including strict liability, ultra hazardous activity, breach of express or implied warranty, imperfection of material, defect or failure of equipment, defect or "ruin" or other condition of premises, or the sole or concurrent negligence or other fault of the party being indemnified.
- 10.5.2 CONCURRENT NEGLIGENCE: EXCEPT AS OTHERWISE SET FORTH IN PARAGRAPHS 10.1.1 AND 10.1.3, THE INDEMNITY, DEFENSE AND HOLD HARMLESS OBLIGATIONS FOR PERSONAL INJURY OR DEATH OR PROPERTY DAMAGE UNDER THIS AGREEMENT SHALL APPLY REGARDLESS OF WHETHER THE INDEMNIFIED PARTY WAS CONCURRENTLY NEGLIGENT (WHETHER ACTIVELY OR PASSIVELY), IT BEING AGREED BY THE PARTIES THAT IN THIS EVENT, THE PARTIES' RESPECTIVE LIABILITY OR RESPONSIBILITY FOR SUCH DAMAGES, LOSSES, COSTS AND EXPENSES UNDER THIS PARAGRAPH 10 SHALL BE DETERMINED IN ACCORDANCE WITH PRINCIPLES OF COMPARATIVE NEGLIGENCE.
- 10.5.3 Louisiana Oilfield Anti-Indemnity Act Willbros and Cheniere agree that the Louisiana Oilfield Anti-Indemnity Act, LA. REV. STAT. § 9:2780, ET. SEQ., is inapplicable to this Agreement and the performance of the Work. Application of these code sections to this Agreement would be contrary to the intent of the Parties, and each Party hereby irrevocably waives any contention that these code sections are applicable to this Agreement or the Work. In addition, it is the intent of the Parties in the event that the aforementioned act were to apply that each Party shall provide insurance to cover the losses contemplated by such code sections and assumed by each such Party under the indemnification provisions of this Agreement, and Willbros agrees that the payments made to Willbros hereunder compensate Willbros for the cost of premiums for the insurance provided by it under this Agreement. The Parties agree that each Party's agreement to support their indemnification obligations by insurance shall in no respect impair their indemnification obligations.
- 10.5.4 Conflict with Applicable Law: In the event that any indemnity provisions in this Agreement are contrary to the law governing this Agreement, then the indemnity

## **11. INSURANCE**

- 11.1 **Willbros' Insurance**: All insurance obtained pursuant to this Agreement shall: (1) be issued by insurers with an "A-X" or better A.M. Best Co. rating in the current Property-Casualty Edition and authorized to do business in the state in which the Project is located, and (2) be in all other respects acceptable to Cheniere. Willbros shall carry and maintain or cause to be carried and maintained in force at all times during the term of the Agreement the following insurance:
- 11.1.1 **Workers' Compensation/Employers' Liability**  
Workers' compensation with appropriate longshoremen's or harbor workers' endorsement (if applicable) covering all Willbros Personnel in accordance with the statutory requirements of the state of hire or country in which the Work is to be performed, and if the Work includes the use of vessels, appropriate maritime extensions. Employers' liability insurance with the limit of One Million United States Dollars (U.S. \$1,000,000) per accident or illness.
- 11.1.2 **Commercial General Liability**  
Commercial general liability insurance with contractual liability, products and completed operations, and broad form property damage coverage included, which shall provide for a combined single limit of One Million United States Dollars (U.S. \$1,000,000) for personal injury, death or property damage resulting from each occurrence and covering all of Willbros' Work under the Agreement; provided, however, this coverage requirement may be satisfied by Willbros through any combination of primary and excess liability insurance.
- 11.1.3 **Automobile Liability**  
Automobile liability insurance covering owned, non-owned and hired motor vehicles, with combined single limits of at least One Million United States Dollars (U.S. \$1,000,000) for personal injury, death, or property damage resulting from each occurrence.
- 11.1.4 **Aircraft Liability Insurance**  
Aircraft liability insurance, to the extent applicable, covering owned, non-owned and hired aircraft with a combined single limit of Five Million United States Dollars (U.S. \$5,000,000) for bodily injury, death and property damage resulting from each occurrence.

---

11.1.5 Transportation Insurance

“All Risk” Insurance covering the full replacement cost of all supplies, equipment and materials to be incorporated into the Work while in the course of transit, including the land portion of any ocean or air shipments, and until arrival at the final local Work Sites. Such transit insurance shall include coverage against the perils of war, strikes, riots and civil commotion and shall insure all general average and salvage charges for which named insureds are responsible. Such insurance shall have a deductible of Fifty Thousand United States Dollars (U.S. \$50,000) per loss.

11.1.6 Builder’s Risk Insurance

Completed value form builder’s risk property insurance (subject to a deductible per loss not to exceed \$50,000) upon the entire Work for one hundred percent (100%) of the full replacement cost value thereof (100% includes additional costs of engineering services in the event of a loss). This policy shall include the interests of Cheniere Group and Willbros Group in the Work as named insureds, as their interests may appear, shall name Cheniere as the loss payee, and shall be on an “All Risk” basis for physical loss or damage including fire, flood, earthquake, subsidence, hail, theft, vandalism and malicious mischief and shall include coverage for portions of the Work while it is stored off the Work Site or is in transit (except as otherwise covered by Paragraph 11.1.5). This policy shall provide, by endorsement or otherwise, that Willbros shall be solely responsible for the payment of all premiums under the policy, and that the Cheniere Group shall have no obligation for the payment thereof, notwithstanding that the Cheniere Group are named insureds under the policy. Willbros shall be responsible for any loss within the deductible of the policy for the liabilities assumed by Willbros hereunder.

- 
- 11.1.7 Errors and Omissions Insurance  
Errors and Omissions Professional Liability Insurance (“E&O Insurance”) having minimum limits of Five Million United States Dollars (U.S.\$5,000,000) per claim and in the aggregate, with a deductible not in excess of Two Hundred Fifty Thousand United States Dollars (U.S.\$250,000) per claim and in the aggregate, on a claims made basis. E&O Insurance shall cover liability arising out of or based upon any negligent design, engineering or other professional services performed by Willbros or any of its Subcontractors which is required as or associated with any part of the Work. The E&O Insurance shall have a retroactive date prior to the performance of any Work to be provided under this Agreement, shall have a policy period or renewal period extending through the termination or expiration of this Agreement and for two (2) years thereafter, and shall state that in the event of cancellation or non-renewal, the discovery period for insurance claims (tail coverage) shall be at least thirty-six (36) months.
- 11.1.8 Excess Liability Insurance  
Umbrella or excess liability insurance, written on a “following form” basis and providing coverage in excess of the coverages required to be provided by Willbros for employer’s liability insurance, commercial general liability insurance and automobile liability insurance, with limits of Twenty-Five Million United States Dollars (U.S.\$25,000,000) combined single limit each claim and in the aggregate.
- 11.2 Notice: Willbros shall have the insurance carriers furnish to Cheniere, upon the Effective Date and annually thereafter, insurance certificates specifying the types and amounts of coverage in effect and the expiration dates of each policy, and a statement that no insurance will be canceled or materially changed without thirty (30) days prior written notice to Cheniere.
- 11.3 Waiver of Subrogation: All policies of insurance required to be provided by Willbros under this Agreement shall include clauses providing that each underwriter shall waive its rights of recovery, under subrogation or otherwise, against the Cheniere Group for the liabilities assumed by Willbros hereunder. Insurance policies pursuant to Paragraphs 11.1.2, 11.1.3, 11.1.4, 11.1.5, 11.1.6 and 11.1.8 shall designate Cheniere as additional insured for the liabilities assumed by Willbros hereunder, and that the policies provided by Willbros shall be primary and noncontributing to any insurance carried by Cheniere with regard to the liabilities assumed by Willbros hereunder. The policies referred to in Paragraphs 11.1.2 and 11.1.3 shall contain a cross-liability clause in respect of third party claims so that Cheniere and Willbros are regarded as third parties as to each other.
- 11.4 Obligations Not Relieved: Except as otherwise provided in this Agreement to the contrary, the occurrence of any of the following shall in no way relieve Willbros from any of its obligations under this Agreement: (i) failure by Willbros to secure or maintain the insurance coverage required hereunder; (ii) failure by Willbros to comply fully with any

- of the insurance provisions of this Agreement; (iii) failure by Willbros to secure such endorsements on the policies as may be necessary to carry out the terms and provisions of this Agreement; (iv) the insolvency, bankruptcy or failure of any insurance company providing insurance to Willbros; (v) failure of any insurance company to pay any claim accruing under its policy; or (vi) losses by Willbros or any of its Subcontractors or Vendors not covered by insurance policies.
- 11.5 Subcontractors' and Vendors' Insurance: If Willbros subcontracts any part of the Work, Willbros shall obtain or require its Subcontractors and Vendors to maintain, the same insurance coverage and amounts that Willbros is required to maintain pursuant to this Paragraph 11, as applicable and appropriate to the Work of such Subcontractor or Vendor.
- 11.6 Parent Guarantee: Willbros will guarantee the full and faithful performance of all obligations of Willbros under this Agreement by providing Cheniere with a parent guarantee in the form attached as Attachment I.
- 11.7 Performance and Payment Bonds: Prior to commencement of the construction component of the Work and in any event no later than thirty (30) days prior to Cheniere's payment to Willbros of the down payment for such Work in accordance with Paragraph 1.4.1(i) of Attachment I to the Letter Agreement, Willbros shall cause the construction Subcontractor to provide to Cheniere and maintain performance and payment bonds in the form of Attachment II and in an amount equal to the amount of the cost of construction, as indicated in the Schedule of Values. Such bonds shall be provided by a surety licensed to transact business in the State of Louisiana, U.S. Department of Treasury listed and otherwise approved by Cheniere, which approval shall not be unreasonably withheld. Each bond shall also attach the respective dual obligee riders set forth in Attachment II, naming Cheniere as a dual obligee under each bond. The premium of such bonds shall be reimbursed to Willbros by Cheniere and shall be included in the Guaranteed Maximum Price.
- 11.8 Limitation of Liability. Notwithstanding any other provision of this Agreement, under no circumstance shall the liability of Willbros to Cheniere in connection with the Work exceed in the cumulative aggregate fifteen percent (15%) of the cost of construction, as indicated in the Schedule of Values and as may be adjusted by Change Order, provided that, notwithstanding the foregoing, the limitation of liability set forth in this Paragraph 11.8 shall not (i) apply in the event of Willbros' willful misconduct (including the willful refusal to perform the Work, willful delay in performing the Work or abandonment of the Work) or gross negligence; (ii) apply to Willbros' indemnification obligations under this Agreement; or (iii) include the payment of proceeds under any insurance policy required to be provided by Willbros under Paragraph 11.1, Cheniere or any Subcontractor or Vendor. In no event shall the limitation of liability set forth in this Paragraph 11.8 be in any way deemed to limit Willbros' obligation to perform all Work required to achieve Mechanical Completion, Start-up and Project Completion. The costs incurred by Willbros in performing the Work (including Corrective Work and other Warranty

obligations but excluding the payment of Liquidated Damages) shall not be counted against the aggregate limitation of liability set forth in this Paragraph 11.8.

## **12. WARRANTY**

12.1 **General:** Any Work, or component thereof, that is not in conformity with any warranties set forth in this Paragraph 12 and elsewhere in this Agreement (collectively, the "Warranty" or "Warranties") is defective ("Defective") and contains a defect ("Defect"). Willbros hereby warrants that the Work and each component thereof shall be:

- 12.1.1 new, complete, fit for the purposes specified in this Agreement and of suitable grade for the intended function and use;
- 12.1.2 in accordance with all of the requirements of this Agreement, including in accordance with good engineering and construction practices, Applicable Law and Applicable Codes and Standards;
- 12.1.3 free from encumbrances to title, as set forth in greater detail in Paragraph 10.2; and
- 12.1.4 free from defects in design, material and workmanship and otherwise conform to the standards and requirements contained in the Specifications and elsewhere in this Agreement.

Willbros and its Subcontractors and Vendors shall exercise that high degree of skill and judgment normally exercised by firms performing services of a similar nature.

12.2 **Correction of Work:**

- 12.2.1 **Prior to Start-up:** Willbros' obligations to correct Work prior to Start-up are set forth in Paragraph 7.4.
- 12.2.2 **After Start-up:** If within twelve (12) months after Start-up (the "Defect Correction Period") any Work is found to be Defective, Willbros shall, at its sole cost and expense, immediately and on an expedited basis correct such Defective Work and any other portions of the Project damaged or affected by such Defective Work, whether by repair, replacement or otherwise ("Corrective Work") and shall be liable for and pay to Cheniere any and all costs, losses, damages and expenses incurred by Cheniere arising out of or relating to such Defective Work. Cheniere shall provide Willbros with access to the Project sufficient to perform its Corrective Work, so long as such access does not unreasonably interfere with operation of the Project and subject to any reasonable security or safety requirements of Cheniere. In the event Willbros utilizes spare parts owned by Cheniere in the course of performing the Corrective Work, Willbros shall supply Cheniere free of charge with new spare parts equivalent in quality and quantity to

---

all such spare parts used by Willbros as soon as possible following the utilization of such spare parts.

- 12.2.3 Cheniere's Right to Correct or Complete Defective Work: If Willbros fails to commence the Corrective Work within a reasonable period of time not to exceed forty-eight (48) hours, or does not complete such Corrective Work on an expedited basis, then Cheniere, by written notice to Willbros, may (without prejudice to any other remedies that it may have under this Agreement) correct such Defective Work, and Willbros shall be liable to Cheniere for all costs, losses, damages and expenses incurred by Cheniere in connection with correcting such Defective Work and arising out of or relating to such Defective Work and shall pay Cheniere (directly, or by offset, at Cheniere's sole discretion) an amount equal to such costs, losses, damages and expenses; provided, however, if such Defective Work presents an imminent threat to the safety or health of any person and Cheniere knows of such Defective Work, Cheniere may (without prejudice to any other remedies that it has under this Agreement) correct such Defective Work without giving prior written notice to Willbros, and, in that event, Willbros shall be liable to Cheniere for all reasonable costs, losses, damages and expenses incurred by Cheniere in connection with correcting such Defective Work and arising out of or relating to such Defective Work and shall pay Cheniere (directly or by offset, at Cheniere's sole discretion) an amount equal to such costs, losses, damages and expenses.
- 12.2.4 Extended Defect Correction Period for Corrective Work: With respect to any Corrective Work performed, the Defect Correction Period for such Corrective Work shall be extended for an additional twelve (12) months from the date of the completion of such Corrective Work; provided, however, in no event shall the Defect Correction Period for such Corrective Work be less than the original Defect Correction Period. In no event shall the Defect Correction Period plus any extended Defect Correction Period exceed a total period of twenty-four (24) months.
- 12.2.5 Standards for Corrective Work: All Corrective Work shall be performed subject to the same terms and conditions under this Agreement as the original Work is required to be performed.
- 12.2.6 No Limitation: Nothing contained in this Paragraph 12.2 shall be construed to establish a period of limitation with respect to other obligations which Willbros might have under the Agreement. Establishment of the Defect Correction Period relates only to the specific obligation of Willbros to perform Corrective Work, and has no relationship to the time within which the obligation to comply with this Agreement may be sought to be enforced, nor to the time within which proceedings may be commenced to establish Willbros' liability with respect to Willbros' obligations other than specifically to perform Corrective Work. In addition, all representations, Warranties and obligations to perform Corrective



---

Work set forth in this Agreement, including those in this Paragraph 12, shall be in addition to and shall in no way limit Willbros' obligation to perform all Work necessary to achieve Project Completion.

12.2.7 Vendor Correction of Work Warranties for Materials or Equipment: Notwithstanding anything to the contrary in this Agreement, with respect to any materials or equipment procured by Willbros from a Vendor, Willbros' liability during the Defect Correction Period for such materials and equipment shall be limited to "passing through" to Cheniere the benefits of any correction of Work warranty received from the applicable Vendor, which correction of Work obligation shall be deemed to run to the benefit of Cheniere. Willbros shall use its best efforts to obtain a correction of Work warranty identical to Willbros' correction of Work obligations set forth in Paragraph 12.2.2, but in no event shall such correction of Work obligations be less than industry standard and otherwise reasonable to protect Cheniere from Defective Work. Willbros shall use its best efforts to cause such Vendors to perform their obligations under such warranties, and shall cooperate with Cheniere's efforts to enforce such warranties with any such Vendors. Willbros shall assign in full, and without cost to Cheniere, all such warranties from such Vendors. In the event of a Dispute during the Defect Correction Period as to whether Defective Work relates to a Defect in workmanship (and, therefore, is covered by Paragraph 12.2.2) or a Defect in material or equipment provided by a Vendor (and, therefore, is covered by this Paragraph 12.2.7), anything in this Paragraph notwithstanding, Willbros shall, at Cheniere's direction and subject to the dispute resolution procedure set forth in Article 14, perform Corrective Work during the Defect Correction Period unless Willbros successfully causes such Vendor to perform its correction of Work obligations in accordance with the terms of the applicable purchase order.

12.3 Assignment and Enforcement of Subcontractor Warranties: Willbros shall, without additional cost to Cheniere, obtain Warranties from Subcontractors that meet or exceed the requirements of this Agreement; provided, however, Willbros shall not in any way be relieved of its responsibilities and liability to Cheniere under this Agreement, regardless of whether such Subcontractor Warranties meet the requirements of this Agreement, as Willbros shall be fully responsible and liable to Cheniere for its Warranty and corrective Work obligations and liability under this Agreement for all Work. All such Warranties shall be deemed to run to the benefit of Cheniere and Willbros. Such Warranties, with duly executed instruments assigning the Warranties to Cheniere, shall be delivered to Cheniere upon Start-up. All Warranties provided by any Subcontractor shall be in such form as to permit direct enforcement by Willbros or Cheniere against any Subcontractor whose Warranty is called for, and Willbros agrees that: (i) Willbros' Warranty, as provided under this Paragraph 12 shall apply to all Work regardless of the provisions of any Subcontractor Warranty, and such Subcontractor Warranties shall be in addition to, and not a limitation of, such Willbros Warranty; (ii) Willbros is jointly and severally liable with such Subcontractor with respect to such Subcontractor Warranty; and (iii)

---

service of notice on Willbros that there has been a breach of a Subcontractor Warranty shall be sufficient to invoke the terms of the instrument.

- 12.4 Survival of Warranties: All representations and Warranties set forth in this Agreement, including those in this Paragraph 12, shall survive Project Completion or the earlier termination of this Agreement.

**13. TITLE TO THE WORK AND TO WORK PRODUCT.**  
**CONFIDENTIAL INFORMATION**

- 13.1 Title: The title to all or any portion of the Work (other than Work Product) shall pass to Cheniere upon the earlier of (a) payment by Cheniere therefore, or (b) incorporation of such Work into the Work Site. Notwithstanding the foregoing, title to all materials furnished by Cheniere, irrespective of the location thereof, as between Cheniere and Willbros or any Subcontractor or Vendor, shall be in Cheniere. Transfer of title to Work shall be irrespective of the passage of risk of loss pursuant to Paragraph 13.2 and shall be without prejudice to Cheniere's right to reject Defective Work or any other right in this Agreement.
- 13.2 Risk of Loss: Notwithstanding passage of title pursuant to Paragraph 13.1, Willbros shall bear the risk of loss and damage to Work until the earlier of Start-up or termination of this Agreement; provided that Cheniere shall at all times bear the risk of physical loss and damage if and to the extent arising from (i) war (whether declared or undeclared), civil war, act of terrorism, sabotage, blockade, insurrection; or (ii) ionizing radiation, or contamination by radioactivity from nuclear fuel, or from any nuclear waste from the combustion of nuclear fuel properties of any explosive nuclear assembly or nuclear component thereof. In the event that any physical loss or damage to the Work arises from one or more of the events set forth in the preceding sentence, and Cheniere elects to rebuild such physical loss or damage, Willbros shall be entitled to a Change Order to the extent such event adversely affects (i) Willbros' costs of performance of the Work; (ii) Willbros' ability to perform the Work in accordance with the Work Plan or (iii) Willbros' ability to perform any material obligation under this Agreement; provided that Willbros complies with the requirements set forth in Paragraphs 9.5 and 14.1.
- 13.3 Ownership of Work Product: Subject to Paragraph 13.4, all materials which Willbros or any Subcontractor or Vendor is required to furnish, prepare or develop in the performance and completion of Work hereunder (whether delivered to Cheniere or not), including reports, plans, Drawings and Specifications, calculations, maps, sketches, notes, data and samples (collectively, "Work Product"), shall be "works for hire," and all rights, title and interests to the Work Product, including any and all copyrights in the Work Product, shall be the sole and exclusive property of Cheniere without limitation (except Willbros may retain a copy thereof in accordance with this Agreement), subject only to Willbros' right to use the same to perform the Work. Such Work Product (including all copies thereof) shall, together with any materials furnished by Cheniere hereunder, be delivered to Cheniere upon request and in any event upon completion or termination of this

Agreement. All such Work Product shall be considered to be Cheniere's Confidential Information and is subject to the confidentiality obligations in Paragraph 13.6. If for any reason any part of or all of the Work Product is not considered work for hire for Cheniere or if ownership of all right, title and interest in the Work Product shall not otherwise vest in Cheniere, then Willbros agrees that such ownership and copyrights in the Work Product, whether or not such Work Product is fully or partially complete, shall be automatically assigned from Willbros to Cheniere, without further consideration, and Cheniere shall thereafter own all right, title and interest in the Work Product, including all copyright interests.

13.4 Willbros Intellectual Property: As between Cheniere and Willbros, Willbros shall retain ownership of any intellectual property rights owned by Willbros or developed by Willbros outside this Agreement and prior to the Effective Date ("Willbros' Intellectual Property"). To the extent any Willbros' Intellectual Property is incorporated, in whole or in part, into the Work Product, Willbros shall provide prior written notice thereof to Cheniere. Cheniere shall be entitled to use Willbros' Intellectual Property and Willbros hereby grants Cheniere an irrevocable and royalty-free license to use and modify Willbros' Intellectual Property for the sole purposes of: (i) operating and maintaining the Project; (ii) assisting in the performance of the Work; or (iii) repairing, replacing, expanding, completing or modifying any portion of the Work or the Project. Cheniere shall be entitled to assign its rights in such license, provided that such assignee shall only use such license for the purposes specified in (i) through (iii) above.

13.5 Cheniere's Use of the Work Product and Willbros' Intellectual Property for Other Projects In addition to the license granted in Paragraph 13.4, Cheniere shall be entitled to use the Work Product and Willbros hereby grants solely to Cheniere an irrevocable and royalty-free license, non-transferable and non-assignable (except as set forth below) to use Willbros' Intellectual Property embedded in the Work Product, in each case solely for the purpose of developing other projects owned in whole or part by Cheniere, including the Corpus Christi and Creole Trail projects, provided that (i) Cheniere shall first remove all references to Willbros and the Project from the Work Product and Willbros' Intellectual Property embedded in the Work Product, (ii) the use of any of Willbros' Intellectual Property on such other projects shall be limited to such Willbros' Intellectual Property which is embedded in the Work Product; and (iii) Cheniere shall not assign (except to an affiliated company of Cheniere) such Work Product or license without Willbros' consent, which consent shall not be unreasonably withheld or delayed. CHENIERE SHALL DEFEND, INDEMNIFY AND HOLD WILLBROS HARMLESS FROM AND AGAINST ALL DAMAGES, LOSSES, COSTS AND EXPENSES (INCLUDING ALL REASONABLE ATTORNEYS' FEES AND LITIGATION OR ARBITRATION EXPENSES) INCURRED BY WILLBROS AND CAUSED BY USE OF THE WORK PRODUCT OR WILLBROS' INTELLECTUAL PROPERTY IN CONNECTION WITH PROJECTS OTHER THAN THE PROJECT WHICH IS THE SUBJECT OF THIS AGREEMENT.

- 13.6 Willbros' Confidentiality Obligations: Willbros hereby covenants and warrants that Willbros and its employees and agents shall not (without in each instance obtaining Cheniere's prior written consent) disclose, make commercial or other use of, or give or sell to any person or entity any of the following information: (i) any Work Product other than to Subcontractors or Vendors as necessary to perform the Work or (ii) any other information relating to the business, products, services, research or development, clients or customers of Cheniere or any member of the Cheniere Group, or relating to similar information of a third party who has entrusted such information to Cheniere or any member of the Cheniere Group (hereinafter individually or collectively, "Cheniere's Confidential Information"). Prior to disclosing any information in (i) of this Paragraph 13.6 to any Subcontractor or Vendor as necessary to perform the Work, Willbros shall bind such Subcontractor or Vendor to the confidentiality obligations contained in this Paragraph 13.6 and to the term in Paragraph 13.11. Nothing in this Paragraph 13.6 or this Agreement shall in any way prohibit Willbros or any of its Subcontractors or Vendors from making commercial or other use of, selling, or disclosing any of their respective Willbros' Intellectual Property.
- 13.7 Cheniere's Confidentiality Obligations: Cheniere hereby covenants and warrants that Cheniere and its employees and agents shall not (without in each instance obtaining Willbros' prior written consent) disclose, make commercial or other use of, or give or sell to any person or entity any pricing methodologies or pricing information (other than the Guaranteed Maximum Price or actual expenditures made by Willbros under this Agreement) relating to the Work, which is conspicuously marked and identified in writing as confidential by Willbros (hereinafter individually or collectively, "Willbros' Confidential Information"). The Parties agree that Cheniere may disclose Willbros' Confidential Information to any member of the Cheniere Group, underwriters, a bona fide prospective purchaser of all or a portion of Cheniere's or any member of the Cheniere Group's assets or ownership interests, a bona fide prospective assignee of all or a portion of Cheniere's interest in this Agreement, lender and its representatives, rating agencies or any other party in relation to project financing for the Project, provided that Cheniere binds such persons or entity to the confidentiality obligations contained in this Paragraph 13.7 and to the term in Paragraph 13.11.
- 13.8 Definitions: The term "Confidential Information" shall mean one or both of Willbros' Confidential Information and Cheniere's Confidential Information, as the context requires. The Party having the confidentiality obligations with respect to such Confidential Information shall be referred to as the "Receiving Party," and the Party to whom such confidentiality obligations are owed shall be referred to as the "Disclosing Party."
- 13.9 Exceptions: Notwithstanding Paragraphs 13.6 and 13.7, Confidential Information shall not include: (i) information which at the time of disclosure or acquisition is in the public domain, or which after disclosure or acquisition becomes part of the public domain without violation of this Paragraph 13; (ii) information which at the time of disclosure or acquisition was already in the possession of the Receiving Party or its employees or

agents and was not previously acquired from the Disclosing Party or any of its employees or agents directly or indirectly; (iii) information which the Receiving Party can show was acquired by such entity after the time of disclosure or acquisition hereunder from a third party without any confidentiality commitment, if, to the best of Receiving Party's or its employees' or agent's knowledge, such third party did not acquire it, directly or indirectly, from the Disclosing Party or any of its employees or agents; (iv) information independently developed by the Receiving Party without benefit of the Confidential Information, but specifically excluding the Work Product; and (v) information which is required by Applicable Law or other agencies in connection with the Project, to be disclosed; provided, however, that prior to such disclosure, the Receiving Party gives reasonable notice to the Disclosing Party of the information required to be disclosed so that the Disclosing Party may attempt to seek an appropriate protective order or other remedy.

- 13.10 Equitable Relief. The Parties acknowledge that in the event of a breach of any of the terms contained in this Paragraph 13, the Disclosing Party would suffer irreparable harm for which remedies at law, including damages, would be inadequate, and that the Disclosing Party shall be entitled to seek equitable relief therefor by injunction, in addition to any and all rights and remedies available to it at law and in equity, without the requirement of posting a bond.
- 13.11 Term. The confidentiality obligations of this Paragraph 13 shall survive the expiration or termination of this Agreement for a period of five (5) years following the expiration or earlier termination of this Agreement.
- 13.12 Disclosure and Filings. Willbros acknowledges that Cheniere may be required from time to time to make filings in compliance with Applicable Law, including filing a copy of this Agreement with the U.S. Securities and Exchange Commission.

#### **14. DISPUTE RESOLUTION**

- 14.1 Time Requirements for Claims: Should Willbros desire to seek an adjustment to the Guaranteed Maximum Price, the Project Schedule or any other modification to any other obligation of Willbros under this Agreement for any circumstance that Willbros has reason to believe may give rise to a right to request the issuance of a Change Order, Willbros shall, with respect to each such circumstance:
- 14.1.1 notify Cheniere in writing within fourteen (14) days of the date that Willbros knew or reasonably should have known of the first occurrence or beginning of such circumstance. In such notice, Willbros shall state in detail all known and presumed facts upon which its claim is based, including the character, duration and extent of such circumstance, the date Willbros first knew of such circumstance, any activities impacted by such circumstance, the cost and time consequences of such circumstance (including showing the impact of such circumstance, if any, on the critical path of the Work Plan) and any other details

or information that are expressly required under this Agreement. Willbros shall only be required to comply with the notice requirements of this Paragraph 14.1 once for continuing circumstances, provided the notice expressly states that the circumstance is continuing and includes Willbros' best estimate of the time and cost consequences of such circumstance; and

- 14.1.2 submit to Cheniere a request for a proposed Change Order as soon as reasonably practicable after giving Cheniere written notice but in no event later than fourteen (14) days after the completion of each such circumstance, together with a written statement (i) detailing why Willbros believes that a Change Order should be issued, plus all documentation reasonably requested by or necessary for Cheniere to determine the factors necessitating the possibility of a Change Order and all other information and details expressly required under this Agreement; and (ii) setting forth the effect, if any, which such proposed Change Order would have for the Work on the Guaranteed Maximum Price and the Project Schedule.

The Parties acknowledge that Cheniere will be prejudiced if Willbros fails to provide the notice required under this Paragraph 14.1, and agree that such requirement is an express condition precedent necessary to any right for an adjustment in the Guaranteed Maximum Price, the Project Schedule, any Work or any other modification to any other obligation of Willbros under this Agreement. Oral notice, shortness of time, or Cheniere's actual knowledge of a particular circumstance shall not waive, satisfy, discharge or otherwise excuse Willbros' strict compliance with this Paragraph 14.1.

- 14.2 Negotiation: In the event that any claim, dispute or controversy arising out of or relating to this Agreement (including the breach, termination or invalidity thereof, and whether arising out of tort or contract) ("Dispute") cannot be resolved informally within thirty (30) days after the Dispute arises, either Party may give written notice of the Dispute ("Dispute Notice") to the other Party requesting that a representative of Cheniere's senior management and Willbros' senior management meet in an attempt to resolve the Dispute. Each such management representative shall have full authority to resolve the Dispute and shall meet at a mutually agreeable time and place within fourteen (14) days after receipt by the non-notifying Party of such Dispute Notice, and thereafter as often as they deem reasonably necessary to exchange relevant information and to attempt to resolve the Dispute. In no event shall this Paragraph 14.2 be construed to limit either Party's right to take any action under this Agreement, including Cheniere's termination rights. The Parties agree that if any Dispute is not resolved within thirty (30) days after receipt of the Dispute Notice given in this Paragraph 14.2, then either Party may by notice to the other Party refer the Dispute to be decided by final and binding arbitration in accordance with Paragraph 14.3.

- 14.3 Arbitration: Any arbitration held under this Agreement shall be held in Houston, Texas, unless otherwise agreed by the Parties, shall be administered by the Dallas, Texas office of the American Arbitration Association ("AAA") and shall, except as otherwise modified by this Paragraph 14.3, be governed by the AAA's Construction Industry

Arbitration Rules and Mediation Procedures (including Procedures for Large, Complex Construction Disputes) (the "AAA Rules"). The number of arbitrators required for the arbitration hearing shall be determined in accordance with the AAA Rules. The arbitrator(s) shall determine the rights and obligations of the Parties according to the substantive law of the state of Texas, excluding its conflict of law principles, as would a court for the state of Texas; *provided, however*, the law applicable to the validity of the arbitration clause, the conduct of the arbitration, including resort to a court for provisional remedies, the enforcement of any award and any other question of arbitration law or procedure shall be the Federal Arbitration Act, 9 U.S.C.A. § 2. Issues concerning the arbitrability of a matter in dispute shall be decided by a court with proper jurisdiction. The Parties shall be entitled to engage in reasonable discovery, including the right to production of relevant and material documents by the opposing Party and the right to take depositions reasonably limited in number, time and place, provided that in no event shall any Party be entitled to refuse to produce relevant and non-privileged documents or copies thereof requested by the other Party within the time limit set and to the extent required by order of the arbitrator(s). All disputes regarding discovery shall be promptly resolved by the arbitrator(s). This agreement to arbitrate is binding upon the Parties, Willbros' surety (if any) and the successors and permitted assigns of any of them. At Cheniere's sole option, any other person may be joined as an additional party to any arbitration conducted under this Paragraph 14.3, provided that the party to be joined is or may be liable to either Party in connection with all or any part of any Dispute between the Parties. The arbitration award shall be final and binding, in writing, signed by all arbitrators, and shall state the reasons upon which the award thereof is based. The Parties agree that judgment on the arbitration award may be entered by any court having jurisdiction thereof.

- 14.4 Continued Performance: Notwithstanding any Dispute, so long as Cheniere continues to pay Willbros undisputed amounts in accordance with this Agreement, it shall be the responsibility of Willbros to continue to prosecute all of the Work diligently and in a good and workmanlike manner in conformity with this Agreement. Except to the extent provided in Paragraph 18, Willbros shall have no right to cease performance hereunder or to permit the prosecution of the Work to be delayed. Cheniere shall, subject to its right to withhold or offset amounts pursuant to this Agreement, continue to pay Willbros undisputed amounts in accordance with this Agreement; provided, however, in no event shall the occurrence of any negotiation or arbitration prevent or restrict Cheniere from exercising its rights under this Agreement, at law or in equity, including Cheniere's right to terminate pursuant to Paragraphs 16 or 17.

#### **15. SUSPENSION OF WORK**

- 15.1 Suspension of Work: Cheniere may at any time, whether or not for cause, suspend performance of the Work, or any part thereof, by a Change Order specifying the Work to be suspended and the effective date of such suspension. Willbros shall cease performance of such suspended Work on the effective date of suspension, but shall continue to perform any unsuspended Work and shall take reasonable steps to minimize

any costs associated with such suspension. During any such suspension, Willbros shall take all reasonably necessary actions to maintain and safeguard the suspended Work in a manner as Cheniere may reasonably require. Except when such suspension ordered by Cheniere is the result of or due to the fault or negligence of Willbros or any Subcontractor or Vendor, Willbros shall be entitled to the reasonable costs (including actual, but not unabsorbed, overhead, contingency, risk and reasonable profit) of such suspension incurred during the suspension period, including demobilization and remobilization costs and costs incurred for Willbros Personnel and for Willbros Equipment, at the standby rates, if any, specified in the Letter Agreement, if necessary, along with appropriate supporting documentation to evidence such costs, and a time extension to the Preparation and Material Receipt Commencement Date, the Construction Commencement Date or the Scheduled Mechanical Completion Date if and to the extent permitted under Paragraph 20.2. In no event shall Willbros be entitled to any additional profits or damages due to such suspension.

- 15.2 Resumption of Work: Unless otherwise instructed by Cheniere, Willbros shall during any such suspension maintain its staff and labor on or near the Work Site and otherwise be ready to proceed expeditiously with the Work upon receipt of Cheniere's further instructions. Cheniere may, at any time, authorize resumption of all or any part of the suspended Work by giving notice to Willbros specifying the part of Work to be resumed and the effective date of such resumption. Suspended Work shall be promptly resumed by Willbros after receipt of such notice.

#### **16. TERMINATION AT CHENIERE'S CONVENIENCE**

- 16.1 Cheniere's Rights to Terminate for Convenience: Cheniere may, at any time and at its sole convenience, terminate the Agreement or any part of the Work by giving notice to Willbros specifying the Work to be terminated and the effective date of termination.
- 16.2 Obligations upon Termination for Convenience: Should Cheniere issue a termination notice in accordance with Paragraph 16.1, Willbros shall stop performance of the Work involved on the effective date of termination, unless Cheniere directs Willbros to complete portions of the Work in progress. Such termination shall be effective in the manner specified in the notice, and upon receipt of such notice, Willbros shall, unless the notice directs otherwise, comply with the obligations set forth in Paragraph 19. Upon such termination, it is agreed that the obligations of this Agreement shall continue as to Work already performed. It is further agreed in the event of such termination that the amounts due Willbros in full and complete settlement of this Agreement shall be the sum of the following:
- 16.2.1 The reasonable value of the Work satisfactorily performed prior to termination (the basis of payment being based on the terms of this Agreement, less previous payments, if any, paid to Willbros under this Agreement), plus



16.2.2 Reasonable direct close-out costs, but in no event shall Willbros be entitled to receive any amount for unabsorbed overhead, contingency or anticipatory profit.

Willbros shall submit all reasonable direct close-out costs to Cheniere for verification and audit within sixty (60) days following the effective date of termination.

#### **17. TERMINATION BY CHENIERE FOR CAUSE**

- 17.1 Default by Willbros: Should Willbros at any time: (a) commit a material breach of the Agreement; (b) cause, by any action or omission, any material stoppage or delay of or interference with the work of Cheniere or its other consultants or contractors; (c) fail to comply with Applicable Law or Applicable Codes and Standards; or (d) become insolvent, have a receiver appointed, make a general assignment or filing for the benefit of its creditors or file for bankruptcy protection, in which such case of insolvency, receivership or assignment the cure provisions found below shall not apply; then, in any such event and without prejudice to any other rights available under this Agreement, Cheniere may provide written notice to Willbros specifying the general nature of the default and demanding cure thereof. If, within seven (7) days after receipt of such notice Willbros has failed to cure such default, or if the default cannot be cured with the exercise of reasonable diligence within such seven (7) days but Willbros fails to commence corrective action and cure such condition within an additional fourteen (14) days, Cheniere may, at its option: (i) take such steps as are necessary to overcome the default or deficiency stated in its notice, in which case Willbros shall be liable to Cheniere for all related costs in connection therewith (including all attorneys' fees, consultant fees and litigation or arbitration expenses) which may be offset by Cheniere at its option; or (ii) terminate for default Willbros' performance of all or part of the Work.
- 17.2 Additional Rights of Cheniere upon Default Termination: In the case of termination for default, Cheniere may, at its option, either itself or through others complete the Work by whatever method Cheniere may deem expedient, including taking possession, for the purposes of completing the Work, of all Willbros Equipment and materials and/or taking assignment of any or all of Willbros subcontracts or purchase orders for the Project. In the event of termination under this Paragraph 17, Willbros shall not be entitled to receive any further payment until the Work shall be fully completed and accepted by Cheniere, and Willbros shall be liable to Cheniere for all costs, damages, losses and expenses (including all attorneys' fees, consultant fees and litigation or arbitration expenses) incurred by Cheniere in completing the Work, either itself or through others, including all Liquidated Damages to the extent payable pursuant to Paragraph 21 of this Agreement.
- 17.3 Conversion: If any termination for default by Cheniere pursuant to Paragraph 17.1 is found to be not in accordance with the provisions of this Agreement or is otherwise deemed to be unenforceable, then such termination shall be deemed to be a termination for convenience as provided in Paragraph 16.

---

## **18. TERMINATION BY WILLBROS**

Should Cheniere fail to pay Willbros undisputed invoiced amounts when due under this Agreement, Willbros may demand in writing that Cheniere comply with the payment terms of this Agreement. If, within forty-five (45) days after Cheniere's receipt of such a demand, Cheniere has not taken satisfactory steps to cure such failure, Willbros may, without prejudice to the exercise of any other rights or remedies which may be available to it, terminate this Agreement by giving Cheniere written notice to that effect. Such termination hereunder by Willbros shall be effective on the date specified in Willbros' termination notice. In the event of termination under this Paragraph 18, Willbros have the rights (and Cheniere shall make the payments) provided for in Paragraph 16 in the event of a Cheniere termination for convenience. The right of Willbros to terminate this Agreement for cause shall be without prejudice to, and not in lieu of, any other remedies available to Willbros under this Agreement.

## **19. WILLBROS' OBLIGATIONS UPON SUSPENSION OR TERMINATION**

- 19.1 Willbros' Obligations: If the Agreement or any portion of the Work is suspended or terminated as provided in Paragraphs 15, 16, 17, or 18 and if Cheniere so requests, Willbros shall:
- 19.1.1 immediately discontinue Work on the date and to the extent specified in the notice;
  - 19.1.2 place no further orders for subcontracts, materials, equipment, or any other items or services except as may be necessary for completion of such portion of the Work as is not discontinued, thereafter execute only that portion of the Work not terminated (if any);
  - 19.1.3 inventory, maintain and turn over to Cheniere all Willbros Equipment or any other equipment or other items provided by Cheniere for performance of the terminated Work;
  - 19.1.4 promptly make every reasonable effort to procure cancellation upon the best terms as are reasonably obtainable under the circumstances and which are satisfactory to Cheniere of any or all subcontracts, purchase orders and rental agreements to the extent they relate to the performance of the Work that is discontinued unless Cheniere elects to take assignment of any such subcontracts, purchase orders and rental agreements pursuant to Paragraph 19.2;
  - 19.1.5 cooperate with Cheniere in the transfer of Work Product, including Drawings, licenses and any other items or information and disposition of Work in progress so as to mitigate damages;
  - 19.1.6 comply with other reasonable requests from Cheniere regarding the terminated Work;

- 19.1.7 do whatever is necessary to preserve and protect Work in progress, to protect materials, equipment and supplies in transit or at the Work Site for the Project, to comply with any Applicable Law and any Applicable Codes and Standards, and to minimize all costs to Cheniere and Willbros resulting from such suspension or termination; and
- 19.1.8 perform all other obligations under Paragraph 17.2.
- 19.2 Assignment of Subcontracts and Other Agreements: If the Agreement or any portion of the Work is suspended or terminated as provided in Paragraphs 15, 16, 17, or 18, Cheniere may, at its sole option, take assignment of any or all subcontracts, purchase orders and rental agreements.

## **20. FORCE MAJEURE AND CHENIERE-CAUSED DELAY**

### 20.1 Force Majeure:

- 20.1.1 Willbros Relief: If the commencement, prosecution or completion of any Work is delayed by Force Majeure, then Willbros shall be entitled to an extension to the Scheduled Mechanical Completion Date to the extent, if any, permitted under Paragraph 20.1.1.1 and an adjustment to the Guaranteed Maximum Price to the extent, if any, permitted under Paragraph 20.1.1.2, provided that Willbros complies with the notice and Change Order request requirements in Paragraph 14.1 and the mitigation requirements in Paragraph 20.4. All time extensions to the Project Schedule and adjustments to the Guaranteed Maximum Price for such delays shall be by Change Order implemented and documented as required under Paragraph 9.
- 20.1.1.1 Willbros shall be entitled to an extension to the Scheduled Mechanical Completion Date for delay that meets the requirements of Paragraph 20.1.1 if and to the extent such delay affects the performance of any Work that is on the critical path of the Work Plan and causes Willbros to achieve Mechanical Completion beyond the Scheduled Mechanical Completion Date, but only if Willbros is unable to proceed with other portions of the Work so as not to cause a delay in the Scheduled Mechanical Completion Date.
- 20.1.1.2 Willbros shall be entitled to an adjustment to the Guaranteed Maximum Price for any delay or prevention that meets the requirements of Paragraph 20.1.1, if such delay or prevention occurs for a continuous period of at least five (5) days in any thirty (30) day period. If Willbros is entitled to such adjustment to the Guaranteed Maximum Price, the adjustment to the Guaranteed Maximum Price shall only include reimbursement for the standby time for Willbros' employees and Willbros Equipment and other standby expenses which are incurred by Willbros after the expiration of such five (5) day period and which

are caused by such Force Majeure and the effects thereof. Willbros shall take all reasonable measures, pursuant to Paragraph 20.4, to mitigate the standby and other Force Majeure costs it incurs, and shall cooperate with Cheniere to help overcome such Force Majeure event. Reimbursement for such standby expenses and other Force Majeure costs shall be subject to an aggregate amount of One Million Five Hundred Thousand Dollars (U.S.\$ 1,500,000).

- 20.1.2 Cheniere Relief. Subject to Paragraph 20.1.3, Cheniere's obligations under this Agreement shall be suspended to the extent that performance of such obligations is delayed by Force Majeure, but only if Cheniere notifies Willbros of the existence of such event of Force Majeure within fourteen (14) days after its occurrence and complies with the mitigation requirements in Paragraph 20.4.
- 20.1.3 Payment Obligations: No obligation of a Party to pay moneys under or pursuant to this Agreement shall be excused by reason of Force Majeure.
- 20.2 Cheniere-Caused Delay: Should Cheniere or any person or entity acting on behalf of or under the control of Cheniere (including to any third party contractors working in connection with the Project) delay the commencement, prosecution or completion of the Work, and if such delay is not in any way attributable to Willbros or its Subcontractors or Vendors but is caused by (a) Cheniere's or such person or entity's active interference in the Work, (b) Cheniere's ordering a Change in the Work (provided that a Change Order has been issued in accordance with Paragraph 9), or (c) Cheniere's or such person or entity's failure to perform its material obligations pursuant to this Agreement, including the failure to provide access to the Work Site in accordance with Paragraph 5.2, then Willbros shall be entitled to an adjustment in the Guaranteed Maximum Price and an extension to the Scheduled Mechanical Completion Date if (i) such delay affects the performance of any Work that is on the critical path of the Work Plan, (ii) such delay causes Willbros to complete the Work beyond the Scheduled Mechanical Completion Date, (iii) Willbros is unable to proceed with other portions of the Work so as not to cause a delay in the Scheduled Mechanical Completion Date and (iv) Willbros complies with the notice and Change Order request requirements in Paragraph 14.1 and the mitigation requirements of Paragraph 20.4. Any adjustment to the Guaranteed Maximum Price shall be for reasonable, additional direct costs incurred by Willbros for such delay meeting the requirements of this Paragraph 20.2, and any adjustments to the Guaranteed Maximum Price or the Project Schedule shall be recorded in a Change Order.
- 20.3 Delay: For the purposes of Paragraph 20, the term "delay" shall include hindrances, disruptions or obstructions, or any other similar term in the industry and the resulting impact from such hindrances, disruptions or obstructions, including inefficiency, impact, or lost production.
- 20.4 Obligation to Mitigate Delay: At all times in the event of a delay, the Parties shall take reasonable actions to mitigate such delay.

---

## 21. LIQUIDATED DAMAGES

- 21.1 Liquidated Damages: If Mechanical Completion occurs after the Scheduled Mechanical Completion Date, Willbros shall pay Cheniere in amounts according to the following schedule for each day of delay until Mechanical Completion occurs ("Liquidated Damages"):
- 21.1.1 one (1) through thirty (30) days after the Scheduled Mechanical Completion Date: Zero U.S. Dollars (\$0) per day; and
  - 21.1.2 thirty-one (31) days through sixty (60) days inclusive after the Scheduled Mechanical Completion Date at Five Thousand Dollars (\$5,000) per day;
  - 21.1.3 sixty-one (61) days through ninety (90) days inclusive after the Scheduled Mechanical Completion Date at Seven Thousand Dollars (\$7,000) per day; and
  - 21.1.4 ninety-one (91) days and thereafter until Mechanical Completion is achieved at Ten Thousand Dollars (\$10,000) per day.
- Provided, however, in no event shall such Liquidated Damages exceed the total sum of Five Hundred Sixty Thousand Dollars (\$560,000), provided that such limitation of liability shall not be construed to limit Willbros' other obligations or liabilities under this Agreement (including its obligations (i) to complete the Work for the compensation provided under this Agreement, (ii) to perform all Work required to achieve Start-up and Project Completion, and (iii) with respect to Warranties), nor shall such limitation of liability apply in the event of Willbros' willful misconduct (including the willful refusal to perform the Work, willful delay in performing the Work or abandonment of the Work) or gross negligence.
- 21.2 Liquidated Damages Not a Penalty: It is expressly agreed that Liquidated Damages payable under this Agreement do not constitute a penalty and that the Parties, having negotiated in good faith for such specific Liquidated Damages and having agreed that the amount of such Liquidated Damages is reasonable in light of the anticipated harm caused by the breach related thereto and the difficulties of proof of loss and inconvenience or nonfeasibility of obtaining any adequate remedy, are estopped from contesting the validity or enforceability of such Liquidated Damages. In the event any Liquidated Damages are held to be unenforceable due to the urging by or on behalf of any member of the Willbros Group, Willbros specifically agrees to pay Cheniere all actual damages incurred by Cheniere in connection with such breach, including any and all consequential damages (such as loss of profits and revenues, business interruption, loss of opportunity and use) and all costs incurred by Cheniere in proving the same.
- 21.3 Payment of Liquidated Damages: With respect to any Liquidated Damages that accrue, Cheniere, at its sole discretion, may either (i) invoice Willbros for such owed Liquidated Damages, and within thirty (30) days of Willbros' receipt of such invoice, Willbros shall

pay Cheniere Liquidated Damages, or (ii) withhold from Willbros amounts that are otherwise due and payable to Willbros in the amount of such Liquidated Damages. In addition, with respect to the achievement of Mechanical Completion, Willbros shall pay Cheniere all Liquidated Damages, if any, owed under this Agreement as a condition precedent to achieving such Mechanical Completion.

## **22. PUBLICITY RELEASES**

Should Willbros or any of its Subcontractors or Vendors desire to publish or release any publicity or public relations materials of any kind relating to the Agreement specifically or the Project generally, Willbros shall first submit such material to Cheniere for review. Willbros shall not publish or release any such material without Cheniere's prior consent, such consent not to be unreasonably withheld.

## **23. GOVERNING LAW**

It is understood that the Agreement is governed by the laws of the State of Texas except to the extent its conflict of law principles would refer to the law of another jurisdiction, the Parties acknowledge that the laws of Louisiana govern the rights and obligations of the Parties as to the validity and enforcement of mechanics' and materialmen's liens. Only to the extent that either Party may seek relief of the courts pursuant to this Agreement, Cheniere and Willbros each hereby submit to the exclusive jurisdiction of the federal and state courts located in Houston, Texas, and agree that service of process may be affected upon them by delivery to the addresses given in the Signature Document.

## **24. GENERAL PROVISIONS**

- 24.1 **Assignment:** The Agreement shall be binding upon and inure to the benefit of the successors and assigns of the Parties to the Agreement. The Agreement may neither be assigned nor transferred by either Party, either in whole or in part, without first obtaining the written consent of the other Party, and any attempt to make such an assignment shall be void; provided, however, that Willbros reserves the right to pledge or assign its rights to payment under this Agreement in accordance with its agreements with its lenders; provided further, however, that in no event shall a pledge or assignment of rights to payment by Willbros create or impose any additional obligation on Cheniere or otherwise void or preclude any rights or privileges of Cheniere or any member of the Cheniere Group under this Agreement. Notwithstanding the foregoing, Cheniere may freely assign this Agreement, in whole or in part, without Willbros' consent to any affiliate or successor of Cheniere or to any third party making a loan to Cheniere or purchasing the Project.
- 24.2 **Ownership and Transfer:** Cheniere represents that, once title is transferred as provided in this Agreement, it is the sole owner of the Project. Cheniere further agrees that any future transferee of any interest in the Project will be subject to the releases and limitations of liability set forth in the Agreement such that the total aggregate liability of Willbros to

- 
- Cheniere and such recipients shall not exceed, relative to any transferee, the limits of liability set forth in the Agreement.
- 24.3 No Waiver: No benefit or right accruing to either Party under the Agreement shall be waived unless the waiver is reduced to writing and signed by both Parties. The waiver, in one instance, of any act, condition or requirement stipulated in the Agreement shall not constitute a continuing waiver or a waiver of any act, condition or requirement or a waiver of the same act, condition or requirement in other instances, unless specifically so stated.
- 24.4 Status of Willbros: Willbros shall be and always remain an independent contractor with respect to the Work performed under the Agreement. Neither Willbros, its Subcontractors, its Vendors, nor the Willbros Personnel shall be deemed to be the servants, agents or employees of Cheniere. Willbros shall exercise control, management and direction over the details and means of performing the Work and shall be subject to the directions of Cheniere only with respect to the scope and general results required.
- 24.5 Third Party Beneficiaries: This Agreement shall not be deemed for the benefit of any third party nor shall it give any person not a Party to the Agreement any right to enforce its provisions.
- 24.6 Survival: The provisions of Paragraphs 9.6, 10, 11, 12, 13, 14, 16, 17, 18, 19, 20 and 23 shall survive the final settlement or termination of the Agreement, for whatever reason.
- 24.7 Severability: Any term or provision of the Agreement judicially determined to be invalid or unenforceable to any entity or circumstance shall be deemed, to such extent, invalid or unenforceable, but the remainder of the Agreement shall remain unaffected and be enforceable according to its terms.
- 24.8 Headings: The headings hereof shall not be considered in interpreting the text of the Agreement and are inserted for convenience of reference only.
- 24.9 Further Assurances: Each Party shall perform the acts and execute and deliver the documents and give reasonable assurances necessary to give effect to the provisions of the Agreement; provided that Cheniere shall only be required to give any such assurances upon a material change in the creditworthiness of Cheniere or upon any other significant adverse change to Cheniere. Any assurances required under this Paragraph 24.9 shall not involve the assumption of obligations greater than those provided for in this Agreement.
- 24.10 Entire Agreement: This Agreement supersedes all previous quotations, proposals, letter agreements, contracts, agreements, understandings and correspondence between the Parties regarding the Work, and constitutes the entire agreement between the Parties concerning the Work. Notwithstanding the foregoing, the Parties acknowledge that the Letter Agreement shall be simultaneously executed with this Agreement. No promise, agreement, representation or modification to the Agreement shall be of any force or effect

between the Parties unless expressly set forth or provided for in the Agreement, a Change Order or an Amendment.

- 24.11 Interpretation: The word “include” or “including” shall mean including without limitation. The words “hereof”, “herein”, “hereunder” and “hereto” refer to the Agreement as a whole, including the Schedules, and not to any particular provision of the Agreement unless expressly indicated. Unless the context clearly requires otherwise, references to the plural include the singular and the singular the plural. References to “days” or a “day” shall mean a calendar day, unless otherwise stated. Where a Party’s approval or acceptance is required, such approval or acceptance shall not be unreasonably delayed.
- 24.12 Lender Requirements: In addition to other assurances provided in this Agreement, Willbros acknowledges that Cheniere has obtained or may obtain financing, which may be project financing, associated with the Work, and Willbros agrees to cooperate with Cheniere and Cheniere’s lenders in connection with such Project financing, including entering into direct agreements with such lenders, as reasonably required by such lenders, covering matters that are customary in project financings of this type such as lender assignment or security rights with respect to this Agreement, consent agreements, opinions of counsel, direct notices to lender and lender’s independent engineer, step-in/step-out rights, access by lender’s representative, including lender’s independent engineer, and other matters applicable to such Project financing. Willbros shall cooperate with any independent engineer retained by Cheniere’s lender(s) in the conduct of such independent engineers’ duties in relation to the Project, including the Work. No review, approval or disapproval by any independent engineer shall serve to reduce or limit the liability of Willbros to Cheniere under this Agreement.
- 24.13 Counterparts: This Agreement may be signed in any number of counterparts and each counterpart shall represent a fully executed original as if signed by each of the Parties. Facsimile signatures shall be deemed as effective as original signatures.
- 24.14 Priority. The documents that form this Agreement are listed below in order of priority, with the document having the highest priority listed first and the one with the lowest priority listed last. Subject to Paragraph 1.6 under the definition of Applicable Codes and Standards regarding conflicts or inconsistencies between any Applicable Codes and Standards, in the event of any conflict or inconsistency between a provision in one document and a provision in another document, the document with the higher priority shall control. In the event of a conflict or inconsistency between provisions contained within the same document, then the provision that requires the highest standard of performance on the part of Willbros shall control. This Agreement is composed of the following documents, which are listed in priority:
- 24.14.1 Change Orders or Amendments to this Agreement;
  - 24.14.2 The Signature Document;



---

24.14.3 This Schedule "A"; and

24.14.4 All other Schedules and Attachments to this Agreement.

END OF SCHEDULE "A"

A-52

ATTACHMENT I

WILLBROS' PARENT GUARANTEE

This GUARANTEE (this "*Guarantee*") effective February 01, 2006, is made by Willbros USA, Inc. organized under the laws of the State of Delaware ("*Guarantor*"), in favor of Cheniere Sabine Pass Pipeline Company, a company organized under the laws of the State of Delaware ("*Owner*," and, together with Guarantor, each a "*Party*" and, collectively, the "*Parties*"). Capitalized terms used, but not otherwise defined, herein shall have the respective meanings ascribed to such terms in the Agreement (as defined below).

RECITALS

**WHEREAS**, Owner has agreed to enter into the Agreement for the Engineering, Procurement and Construction of the 42-inch Sabine Pass Pipeline dated February 01, 2006, with Willbros Engineers, Inc. ("*Willbros*") for the engineering, procurement, construction, commissioning, start-up and testing of the 42-inch Sabine Pass Pipeline Project (the "*Project*") located in Cameron Parish, Louisiana and a letter agreement dated February 01, 2006, with Willbros (collectively, the "*Agreement*"), which are hereby incorporated by reference in this Guarantee and made a part hereof; and

**WHEREAS**, Willbros is a subsidiary of Guarantor; and

**WHEREAS**, it is a condition to Owner and Willbros' entering into the Agreement that Guarantor execute and deliver this Guarantee.

**NOW THEREFORE**, in consideration of the promises and other good and valuable consideration, the receipt and sufficiency of which are hereby acknowledged, the Parties hereby agree as follows:

**1. Guarantee.**

(a) On the terms and subject to the conditions contained herein, Guarantor hereby unconditionally and irrevocably guarantees, to and for the benefit of Owner, the full and punctual performance and payment, as and when each such payment or performance becomes due (whether at the stated due date, by acceleration or otherwise), by or on behalf of Willbros of any and all obligations or amounts owed by Willbros to Owner in connection with and to the extent provided for in the Agreement (the "*Guaranteed Obligations*"). The Guaranteed Obligations of Guarantor hereunder are direct and primary obligations.

(b) This Guarantee is an unconditional, present, and continuing guarantee of performance and payment, and not of collection, is in no way conditioned or contingent upon any attempt to collect from or enforce performance or payment by Willbros or upon any other event, contingency or circumstance whatsoever, and shall remain in full force and effect and be binding upon and against Guarantor and its successors and permitted assigns (and shall inure to the benefit of Owner and its successors, endorsees, transferees, and permitted assigns), without

regard to the validity or enforceability of the Agreement. If, for any reason, Willbros shall fail or be unable duly, punctually, and fully to perform or pay, as and when such performance or payment is due, any of the Guaranteed Obligations, Guarantor shall promptly perform or pay, or cause to be performed or paid, such Guaranteed Obligations.

(c) Guarantor agrees that any judgment from any litigation (or any award resulting from any arbitration, if Owner and Willbros should agree to arbitrate) between Willbros and Owner under the Agreement (whether in contested litigation or arbitration, by default or otherwise) shall be conclusive and binding on the Parties for the purposes of determining Guarantor's obligations under the Guarantee.

(d) Guarantor further agrees to pay to Owner any and all costs, expenses (including, without limitation, all reasonable fees and disbursements of counsel), and damages which may be paid or incurred by Owner in enforcing any rights with respect to this Guarantee, including, without limitation, collecting against Guarantor under this Guarantee.

## **2. Obligations Unconditional, Continuing; Etc.**

Guarantor agrees that the obligations of Guarantor set forth in this Guarantee shall be direct obligations of Guarantor, and such obligations shall be irrevocable and unconditional, shall not be subject to any counterclaim, set-off, deduction, diminution, abatement, recoupment, suspension, deferment, reduction or defense (other than full and strict compliance with its obligations hereunder) based upon any claim Guarantor or any other person may have against Owner or any other person and shall remain in full force and effect without regard to and shall not be released, discharged or in any way affected or impaired by, any circumstance or condition whatsoever (other than full and strict compliance by Guarantor with its obligations hereunder) (whether or not Guarantor shall have any knowledge or notice thereof), including, without limitation: (i) any amendment or modification of or supplement to or other change in the Agreement or any other document, including, without limitation, any change order, renewal, extension, acceleration or other changes to payment terms thereunder; (ii) any failure, omission or delay on the part of Owner or any other person to confirm or comply with any term of the Agreement, (iii) any waiver, consent, extension, indulgence, compromise, release or other action or inaction under or in respect of the Agreement or any other document or any obligation or liability of Owner or any other person, or any exercise or non-exercise of any right, remedy, power, or privilege under or in respect of any such instrument or agreement or any such obligation or liability, other than as expressly set forth in writing executed by Owner and Guarantor; (iv) any bankruptcy, insolvency, reorganization, arrangement, readjustment, liquidation, or similar proceeding with respect to Owner, Willbros or any other person or any of their respective properties, or any action taken by any trustee or receiver or by any court in any such proceeding; (v) any discharge, termination, cancellation, invalidity or unenforceability, in whole or in part, of the Agreement or any other document or any term or provision thereof; (vi) any merger or consolidation of Guarantor or Willbros into or with any other person or any sale, lease, or transfer of all or any of the assets of Guarantor or Willbros; (vii) any change in the ownership of Guarantor or Willbros; (viii) any winding up or dissolution of Willbros; or (ix) to the extent permitted under Applicable Law, any other occurrence or circumstance whatsoever, whether similar or dissimilar to the foregoing, which might otherwise constitute a legal or

---

equitable defense or discharge of the liabilities of guarantor or surety or which might otherwise limit recourse against Guarantor. Guarantor reserves the right to (a) set-off against any payment that has become due and payable by the Owner to Willbros under the Agreement and (b) assert defenses which Willbros may have under or with respect to the Agreement to performance of any Guaranteed Obligations other than defenses arising from the bankruptcy or insolvency of Willbros or Willbros' failure to have the authority to (x) execute or deliver the Agreement or (y) perform its obligations under the Agreement. The Guaranteed Obligations constitute the full recourse obligations of Guarantor enforceable against it to the full extent of all its assets and properties. Without limiting the generality of the foregoing, Guarantor agrees that repeated and successive demands may be made and recoveries may be had hereunder as and when, from time to time, Willbros shall fail to perform obligations or pay amounts owed by Willbros under the Agreement and that notwithstanding the recovery hereunder for or in respect of any given failure to so comply by Willbros under the Agreement, this Guarantee shall remain in full force and effect and shall apply to each and every subsequent such failure.

**3. Reinstatement.** Guarantor agrees that this Guarantee shall be automatically reinstated with respect to any payment made by or on behalf of Willbros pursuant to the Agreement if and to the extent that such payment is rescinded or must be otherwise restored, whether as a result of any proceedings in bankruptcy or reorganization or otherwise.

**4. Waiver of Demands, Notices; Etc.** Guarantor hereby unconditionally waives, to the extent permitted by Applicable Law: (i) notice of any of the matters referred to in Paragraph 2 hereof; (ii) all notices which may be required by Applicable Law, or otherwise, now or hereafter in effect, to preserve any rights against Guarantor hereunder, including, without limitation, any demand, proof, or notice of non-payment or non-performance of any Guaranteed Obligation; (iii) any right to the enforcement, assertion, or exercise of any right, remedy, power, or privilege under or in respect of the Agreement; (iv) notice of acceptance of this Guarantee, demand, protest, presentment, notice of failure of performance or payment, and any requirement of diligence; (v) any requirement to exhaust any remedies or to mitigate any damages resulting from failure of performance or payment by Willbros under the Agreement or by any other person under the terms of the Agreement; and (vi) any other circumstance whatsoever which might otherwise constitute a legal or equitable discharge, release, or defense of a guarantor or surety, or which might otherwise limit recourse against Guarantor.

**5. No Subrogation.** Notwithstanding any performance, payment or payments made by Guarantor hereunder (or any set-off or application of funds of Guarantor by Owner), Guarantor shall not be entitled to be subrogated to any of the rights of Willbros or of any rights of Owner hereunder, or any collateral, security, or guarantee or right of set-off held by Owner, for the performance or payment of the obligations guaranteed hereunder, nor shall Guarantor seek or be entitled to assert or enforce any right of contribution, reimbursement, indemnity or any other right to payment from Willbros as a result of Guarantor's performance of its obligations pursuant to this Guarantee until all Guaranteed Obligations are performed or paid in full. If any amount shall be paid to Guarantor on account of such subrogation, contribution, reimbursement or indemnity rights at any time when all of the Guaranteed Obligations and all amounts owing hereunder shall not have been performed and paid in full, such amount shall be held by Guarantor in trust for Owner, segregated from other funds of Guarantor, and shall, forthwith

upon receipt by Guarantor, be turned over to Owner in the exact form received by Guarantor (duly endorsed by Guarantor to Owner, if required), to be applied against the Guaranteed Obligations, whether or not matured, in such order as Owner may determine.

**6. Representations and Warranties.** Guarantor represents and warrants that:

(a) it is a corporation duly organized and validly existing under the laws of the State of Delaware and has the corporate power and authority to execute, deliver and carry out the terms and provisions of the Guarantee;

(b) the execution, delivery and performance of this Guarantee will not conflict with, violate or breach the terms of any agreement of Guarantor;

(c) no authorization, approval, consent or order of, or registration or filing with, any court or other governmental body having jurisdiction over Guarantor is required on the part of Guarantor for the execution and delivery of this Guarantee; and

(d) this Guarantee, when executed and delivered, will constitute a valid and legally binding agreement of Guarantor, except as the enforceability of this Guarantee may be limited by the effect of any applicable bankruptcy, insolvency, reorganization, moratorium or similar laws affecting creditors' rights generally and by general principles of equity as they apply to the Guarantor.

**7. Miscellaneous.**

(a) This Guarantee shall inure to the benefit of and be binding upon the Parties hereto and their respective successors and permitted assigns. Guarantor may not assign or transfer this Guarantee or any rights or obligations hereunder without Owner's prior written consent. Owner may assign this Guarantee, in whole or part, to any of its affiliates or co-venturers or to any person jointly controlled by Owner and any co-venturers. Furthermore, Owner may assign, pledge and/or grant a security interest in this Guarantee to any lender without Guarantor's consent. Except as otherwise provided in this Paragraph 7, nothing herein, express or implied, is intended or shall be construed to confer upon or to give to any person other than the Parties hereto any rights, remedies, or other benefits.

(b) This Guarantee shall be governed by, and construed in accordance with, the laws of the state of Texas, without giving effect to the principles thereof relating to conflicts of law.

(c) The Parties agree that any claim, dispute, controversy, difference, disagreement, or grievance (of any and every kind or type, whether based on contract, tort, statute, regulation or otherwise) arising out of, connected with, or relating in any way to this Guarantee (including, without limitation, the construction, validity, interpretation, termination, enforceability or breach of this Guarantee, the relationship of the Parties established by this Guarantee, or any dispute over arbitrability or jurisdiction) ("**Dispute**") shall be decided by final and binding arbitration. Any arbitration held under this Guarantee shall be held in Houston, Texas, unless otherwise agreed by the Parties, shall be administered by the Dallas, Texas office of the American Arbitration Association ("**AAA**") and shall, except as otherwise modified by this Paragraph 7(c),

be governed by the AAA's Construction Industry Arbitration Rules and Mediation Procedures (including Procedures for Large, Complex Construction Disputes) (the "AAA Rules"). The number of arbitrators required for the arbitration hearing shall be determined in accordance with the AAA Rules. The arbitrator(s) shall determine the rights and obligations of the Parties according to the substantive law of the state of Texas, excluding its conflict of law principles, as would a court for the state of Texas; provided, however, the law applicable to the validity of the arbitration clause, the conduct of the arbitration, including resort to a court for provisional remedies, the enforcement of any award and any other question of arbitration law or procedure shall be the Federal Arbitration Act, 9 U.S.C.A. § 2. Issues concerning the arbitrability of a matter in dispute shall be decided by a court with proper jurisdiction. The Parties shall be entitled to engage in reasonable discovery, including the right to production of relevant and material documents by the opposing Party and the right to take depositions reasonably limited in number, time and place, provided that in no event shall any Party be entitled to refuse to produce relevant and non-privileged documents or copies thereof requested by the other Party within the time limit set and to the extent required by order of the arbitrator(s). All disputes regarding discovery shall be promptly resolved by the arbitrator(s). This agreement to arbitrate is binding upon the Parties and the successors and permitted assigns of any of them. At Owner's sole option, any other person may be joined as an additional party to any arbitration conducted under this Paragraph 7(c), provided that the party to be joined is or may be liable to either Party in connection with all or any part of any Dispute between the Parties. The arbitration award shall be final and binding, in writing, signed by all arbitrators, and shall state the reasons upon which the award thereof is based. The Parties agree that judgment on the arbitration award may be entered by any court having jurisdiction thereof.

(d) No modification or amendment of this Guarantee shall be of any force or effect unless made in writing, signed by the Parties hereto, and specifying with particularity the nature and extent of such modification or amendment. This Guarantee constitutes the entire and only understanding and agreement among the Parties hereto with respect to the subject matter hereof and cancels and supersedes any prior negotiations, proposals, representations, understandings, commitments, communications, or agreements, whether oral or written, with respect to the subject matter hereof.

(e) All notices, requests and communications to a Party hereunder shall be in writing (including telecopy and/or fax or similar writing) and shall be sent:

If to Owner:

Graham A. McArthur  
Vice President and Treasurer  
Cheniere Sabine Pass Pipeline  
717 Texas Avenue, Suite 3100  
Houston, Texas 77002  
Telephone: (713) 659-1361  
Fax: (713) 659-5459

If to Guarantor:

Gay S. Mayeux  
Vice President and Assistant Treasurer  
Willbros USA, Inc.  
4400 Post Oak Parkway  
Suite 1000  
Houston, Texas 77027  
Telephone: (713) 403-8147  
Fax: (713) 403-8017

or to such other address or telecopy number and with such other copies, as such Party may hereafter reasonably specify by notice to the other Parties. Each such notice, request or communication shall be effective upon receipt, provided that if the day of receipt is not a business day then it shall be deemed to have been received on the next succeeding business day.

(f) The headings of the several provisions of this Guarantee are inserted for convenience only and shall not in any way affect the meaning or construction of any provision of this Guarantee.

(g) No forbearance or delay by Owner in asserting rights against Willbros shall affect or impair in any way Guarantor's obligations hereunder or the rights of Owner hereunder.

(h) In addition to other assurances provided in this Guarantee, Guarantor acknowledges that Owner has obtained or may obtain project financing associated with the Project and Guarantor agrees to cooperate with Owner and its lenders in connection with such project financing, including, but not limited to, entering into direct agreements with lenders, as required by such lenders, covering matters that are customary in project financings of this type such as lender assignment or security rights with respect to this Guarantee, consent agreements, opinions of counsel, direct notices to lender and lender's independent engineer, step-in/step-out rights, access by lenders' representative, including lender's independent engineer, and other matters applicable to such project financing.

(i) This Guarantee may be executed in any number of separate counterparts and all of said counterparts taken together shall be deemed to constitute one and the same instrument.

**IN WITNESS WHEREOF**, the undersigned have duly executed this Guarantee as of the date first above written.

**WILLBROS USA, INC.**

By: /s/ William L. Pardue  
Name: William L. Pardue  
Title: Assistant Corporate Secretary

---

**CHENIERE SABINE PASS PIPELINE  
COMPANY**

By: /s/ Robert Keith Teague

Name: Robert Keith Teague

Title: President



ATTACHMENT II - 1

PAYMENT BOND

Bond No. \_\_\_\_\_

**KNOW ALL MEN BY THESE PRESENTS**, that \_\_\_\_\_ (hereinafter "Principal") and \_\_\_\_\_, incorporated in the state of \_\_\_\_\_ and duly authorized to do business in Louisiana, (hereinafter "Surety"), are held and firmly bound unto Cheniere Sabine Pass Pipeline Company (hereinafter "Obligee"), and its representatives, successors and assigns, in the sum of \_\_\_\_\_ Dollars (\$\_\_\_\_\_) for the payment of which sum well and truly to be made the said Principal and Surety bind themselves, and their respective heirs, administrators, executors, successors and assigns jointly and severally, firmly by these presents.

**WHEREAS**, Principal has been awarded a contract with Obligee for the project known as the 42-inch Sabine Pass Pipeline Project in Cameron Parish, Louisiana (hereinafter called the "Contract") and which Contract is hereby referred to and incorporated by express reference as if fully set forth herein.

**NOW, THEREFORE, THE CONDITION OF THIS OBLIGATION IS SUCH**, that if the Principal shall promptly make payment in full to all persons or entities supplying labor, material, services, utilities and equipment, or any other things in the prosecution of the work provided for in said Contract, and any and all modifications of said Contract that may hereafter be made, and shall indemnify and save harmless said Obligee of and from any and all loss, damage, and expense, including costs and attorneys' fees, which the said Obligee may sustain by reason of Principal's failure to do so, then this obligation shall be null and void; otherwise it shall remain in full force and effect.

The Surety agrees that no change, extension of time, alteration, addition, omission, waiver, or other modification of the terms of either the Contract or in the work to be performed, or in the specifications, or in the plans, or in the contract documents, or any forbearance on the part of either the Obligee or Principal to the other, shall in any way affect its obligation on this Bond, and Surety does hereby waive notice of any such changes, extensions of time, alterations, additions, omissions, waivers, or other modifications.

The Principal and the Surety agree that this Bond shall inure to the benefit of all persons or entities as supplying labor, material, services, utilities and equipment, or any other things in the prosecution of the work provided for in said Contract, as well as to the Obligee, and that any of such persons or entities may maintain independent actions upon this Bond in the name of the person or entities bringing any such action.

The parties executing this Bond on behalf of Principal and Surety represent and warrant that they are duly authorized to bind the Principal and Surety respectively.

IN WITNESS WHEREOF, the above bounden parties have executed this instrument under their several seals this \_\_\_\_\_ day of \_\_\_\_\_, 200\_ the name and corporate seal of each corporate seal of each corporate party being hereto affixed and these presents duly signed by its undersigned representative, pursuant to authority of its governing body.

**PRINCIPAL:**

\_\_\_\_\_  
By: \_\_\_\_\_  
Title: \_\_\_\_\_  
\_\_\_\_\_  
\_\_\_\_\_  
\_\_\_\_\_  
(Principal's Address)

Witness

\_\_\_\_\_  
Or Secretary's Attest  
[SEAL]

**SURETY:**

\_\_\_\_\_  
By: \_\_\_\_\_  
Title: \_\_\_\_\_  
\_\_\_\_\_  
\_\_\_\_\_  
\_\_\_\_\_  
(Surety's Address)

Witness

\_\_\_\_\_  
Or Secretary's Attest  
[SEAL]

[Attach Power of Attorney executed  
by attorney-in-fact on behalf of Surety]

ATTACHMENT II - 2

DUAL OBLIGEE RIDER FOR PAYMENT BOND

This Rider is to be attached to and forms a part of Payment Bond No. \_\_\_\_\_ issued by \_\_\_\_\_ (hereinafter referred to as "Surety"), as Surety, on the \_\_\_\_\_ day of \_\_\_\_\_, 20\_\_ ("Payment Bond").

WHEREAS, on or about the \_\_\_\_\_ day of \_\_\_\_\_, 200\_, \_\_\_\_\_ (hereinafter called the "Principal"), entered into a written agreement with (hereinafter called the "Primary Obligee") for the construction of \_\_\_\_\_ (hereinafter called the "Contract"); and

WHEREAS, the Principal and the Surety executed and delivered to said Primary Obligee the Performance Bond No. \_\_\_\_\_ ("Performance Bond") in connection with the Contract; and

WHEREAS, the Primary Obligee has requested the Principal and the Surety to execute and deliver this Dual Obligee Rider for Payment Bond and the Principal and the Surety have agreed to do so.

NOW, THEREFORE, the undersigned hereby agree and stipulate that Cheniere Sabine Pass Pipeline Company shall be a named obligee (hereinafter referred to as "Additional Obligee") to the Payment Bond, subject to the conditions set forth below:

1. In the event of a material default in payment by the Primary Obligee to the Principal under the terms of the Contract, the right of the Additional Obligee to recover hereunder shall be subject to the condition that the Additional Obligee remedies said material payment default and thereafter continues to make payment to the Principal as required under the terms of the Contract.

2. The aggregate liability of the Surety under the Payment Bond, to any or all of the obligees (Primary and Additional Obligees), as their interests may appear, is limited to the total penal sum of the Payment Bond.

Signed, sealed and dated this \_\_\_\_\_ day of \_\_\_\_\_, 20\_\_.

PRINCIPAL:

\_\_\_\_\_  
By: \_\_\_\_\_  
Title: \_\_\_\_\_  
\_\_\_\_\_  
\_\_\_\_\_  
\_\_\_\_\_

(Principal's Address)

---

Witness

---

Or Secretary's Attest  
[SEAL]

**SURETY:**

By: \_\_\_\_\_

Title: \_\_\_\_\_

\_\_\_\_\_

\_\_\_\_\_

(Surety's Address)

Witness.

---

Or Secretary's Attest  
[SEAL]

[Attach Power of Attorney executed  
by attorney-in-fact on behalf of Surety]

ATTACHMENT II - 3

PERFORMANCE BOND

Bond No. \_\_\_\_\_

**KNOW ALL MEN BY THESE PRESENTS**, that \_\_\_\_\_ (hereinafter "Principal") and \_\_\_\_\_, incorporated in the state of \_\_\_\_\_ and duly authorized to do business in Louisiana (hereinafter "Surety"), are held and firmly bound unto Cheniere Sabine Pass Pipeline Company (hereinafter "Obligee"), and its representatives, successors and assigns, in the sum of \_\_\_\_\_ Dollars (\$\_\_\_\_\_) for the payment of which sum well and truly to be made the said Principal and Surety bind themselves, and their respective heirs, administrators, executors, successors and assigns jointly and severally, firmly by these presents.

**WHEREAS**, Principal has been awarded a contract with Obligee for the project known as the 42-inch Sabine Pass Pipeline Project in Cameron Parish, Louisiana (hereinafter called the "Contract") and which Contract is hereby referred to and incorporated by express reference as if fully set forth herein.

**NOW, THEREFORE, THE CONDITION OF THIS OBLIGATION IS SUCH**, that if the above bounden Principal shall well and truly perform all the work, undertakings, covenants, terms, conditions, and agreements of said Contract within the time provided therein and any extensions thereof that may be granted by Obligee, and during the life of any obligation, guaranty or warranty required under said Contract, and shall also well and truly perform all the undertakings, covenants, terms, conditions, and agreements of any and all modifications of said Contract that may hereafter be made, and shall indemnify and save harmless said Obligee of and from any and all loss, damage, and expense, including costs and attorneys' fees, which the Obligee may sustain by reason of Principal's failure to do so, then this obligation shall be null and void; otherwise it shall remain in full force and effect.

The Surety agrees that no change, extension of time, alteration, addition, omission, waiver, or other modification of the terms of either the Contract or in the work to be performed, or in the specifications, or in the plans, or in the contract documents, or any forbearance on the part of either the Obligee or Surety to the other, shall in any way affect said Surety's obligation on this Bond, and said Surety does hereby waive notice of any such changes, extensions of time, alterations, additions, omissions, waivers, or other modifications. The parties executing this Bond on behalf of Principal and Surety represent and warrant that they are duly authorized to bind the Principal and Surety respectively.

IN WITNESS WHEREOF, the above bounden parties have executed this instrument under their several seals this \_\_\_\_\_ day of \_\_\_\_\_, 200\_, the name and corporate seal of each corporate seal of each corporate party being hereto affixed and these presents duly signed by its undersigned representative, pursuant to authority of its governing body.

---

**PRINCIPAL:**

\_\_\_\_\_  
By: \_\_\_\_\_  
Title: \_\_\_\_\_  
\_\_\_\_\_  
\_\_\_\_\_  
\_\_\_\_\_  
(Principal's Address)

Witness

\_\_\_\_\_  
Or Secretary's Attest  
[SEAL]

**SURETY:**

\_\_\_\_\_  
By: \_\_\_\_\_  
Title: \_\_\_\_\_  
\_\_\_\_\_  
\_\_\_\_\_  
\_\_\_\_\_  
(Surety's Address)

Witness

\_\_\_\_\_  
Or Secretary's Attest  
[SEAL]

[Attach Power of Attorney executed  
by attorney-in-fact on behalf of Surety]

ATTACHMENT II - 4

DUAL OBLIGEE RIDER FOR PERFORMANCE BOND

This Rider is to be attached to and forms a part of Performance Bond No. \_\_\_\_\_ issued by \_\_\_\_\_ (hereinafter referred to as "Surety"), as Surety, on the \_\_\_\_\_ day of \_\_\_\_\_, 20\_\_ ("Performance Bond").

WHEREAS, on or about the \_\_\_\_\_ day of \_\_\_\_\_, 200\_, \_\_\_\_\_ (hereinafter called the "Principal"), entered into a written agreement with \_\_\_\_\_ (hereinafter called the "Primary Obligee") for the construction of \_\_\_\_\_ (hereinafter called the "Contract"); and

WHEREAS, the Principal and the Surety executed and delivered to said Primary Obligee the Payment Bond No. \_\_\_\_\_ ("Payment Bond") in connection with the Contract; and

WHEREAS, the Primary Obligee has requested the Principal and the Surety to execute and deliver this Dual Obligee Rider for Performance Bond and the Principal and the Surety have agreed to do so.

NOW, THEREFORE, the undersigned hereby agree and stipulate that Cheniere Sabine Pass Pipeline Company shall be a named obligee (hereinafter referred to as "Additional Obligee") to the Performance Bond, subject to the conditions set forth below:

1. In the event of a material default in performance by the Primary Obligee to the Principal under the terms of the Contract, the right of the Additional Obligee to recover hereunder shall be subject to the condition that the Additional Obligee remedies said material performance default and thereafter continues to perform as required under the terms of the Contract.

2. The aggregate liability of the Surety under the Performance Bond, to any or all of the obligees (Primary and Additional Obligees), as their interests may appear, is limited to the total penal sum of the Performance Bond.

Signed, sealed and dated this \_\_\_\_\_ day of \_\_\_\_\_, 20\_\_.

PRINCIPAL:

\_\_\_\_\_  
By: \_\_\_\_\_  
Title: \_\_\_\_\_  
\_\_\_\_\_  
\_\_\_\_\_  
\_\_\_\_\_

(Principal's Address)

---

Witness

---

Or Secretary's Attest  
[SEAL]

**SURETY:**

By: \_\_\_\_\_

Title: \_\_\_\_\_

\_\_\_\_\_

\_\_\_\_\_

(Surety's Address)

Witness

---

Or Secretary's Attest  
[SEAL]

[Attach Power of Attorney executed  
by attorney-in-fact on behalf of Surety]



ATTACHMENT III

MECHANICAL COMPLETION CERTIFICATE

Date: \_\_\_\_\_

Cheniere Sabine Pass Pipeline Company  
717 Texas Avenue, Suite 3100  
Houston, Texas 77002  
Attention: Richard E. Keyser

Re: Mechanical Completion Certificate – Sabine Pass Pipeline Project Contract, dated as of February 01, 2006 (the “*Agreement*”), by and between Cheniere Sabine Pass Pipeline Company (“*Cheniere*”) and Willbros Engineers, Inc. (“*Willbros*”)

Pursuant to Paragraph 8.1 of the Agreement, Willbros hereby certifies that it has completed all requirements under the Agreement for Mechanical Completion with respect to the Sabine Pass Pipeline Project (“*Project*”), including: (a) the Work is approved by Cheniere as being ready for pre-commissioning and/or commissioning; (b) Willbros has delivered to Cheniere a set of original test and inspection certificates, including hydrostatic test reports, materials documentation, MAOP establish records, and internal geometry pig results; (c) Willbros has completed all construction, procurement, fabrication, assembly, erection, installation and testing, including final pipeline hydrostatic tests for the pipeline and all appropriate appurtenances to ensure that such systems were correctly constructed, procured, fabricated, assembled, erected, installed and tested and are capable of being operated safely and reliably within the requirements contained in this Agreement; (d) Willbros hereby delivers this Mechanical Completion Certificate as required under Paragraph 8.1 of the Agreement; (e) Willbros has dewatered and dried the pipeline to a dewpoint of negative forty degrees Fahrenheit (-40°F); (f) Willbros has completed all Exception Items in accordance with Paragraph 8.1 of the Agreement; and (g) Willbros has performed all other obligations required under the Agreement for Mechanical Completion.

Willbros certifies that it achieved all requirements under the Agreement for Mechanical Completion on \_\_\_\_\_, 200\_.

Attached is all documentation required to be provided by Willbros under the Agreement to establish that Willbros has achieved all requirements under the Agreement for Mechanical Completion, including the required final pipeline hydrostatic test reports, materials documentation, MAOP establish records, and internal geometry pig results.

**IN WITNESS WHEREOF**, Willbros has caused this Mechanical Completion Certificate to be duly executed by its authorized representative and delivered as of the date first written above.

**WILLBROS ENGINEERS, INC.**

By: \_\_\_\_\_  
Name: \_\_\_\_\_  
Title: Willbros’ Authorized Representative  
Date: \_\_\_\_\_

cc: Cheniere Sabine Pass Pipeline Company  
717 Texas Avenue, Suite 3100  
Houston, Texas 77002  
Attention: Allan Bartz

**ATTACHMENT IV**  
**PROJECT COMPLETION CERTIFICATE**

Date: \_\_\_\_\_

Cheniere Sabine Pass Pipeline Company  
717 Texas Avenue, Suite 3100  
Houston, Texas 77002  
Attention: Richard E. Keyser

Re: Project Completion Certificate – Sabine Pass Pipeline Project Contract, dated as of February 01, 2006 (the “**Agreement**”), by and between Cheniere Sabine Pass Pipeline Company (“**Cheniere**”) and Willbros Engineers, Inc. (“**Willbros**”)

Pursuant to Paragraph 8.3 of the Agreement, Willbros hereby certifies that it has completed all requirements under the Agreement for Project Completion with respect to the Sabine Pass Pipeline Project (“**Project**”), including: (a) the successful achievement of Mechanical Completion of all systems for the Project; (b) the successful achievement of Start-up of all systems for the Project; (c) delivery by Willbros of all documentation required to be delivered under this Agreement, including any Work Product, Cheniere’s Confidential Information and other documentation; (d) delivery by Willbros to Cheniere of fully executed Final Lien and Claim Waivers in the form of Schedule “A”, Attachment X – Part 2 of the Agreement; (e) removal from the Work Site all of Willbros Personnel, supplies, waste, materials, rubbish and temporary facilities and restoration of the Work Site to its natural conditions in accordance with this Agreement, Applicable Law and Applicable Codes and Standards or any other requirements of any Governing Authority; (f) Willbros hereby delivers this Project Completion Certificate as required under Paragraph 8.3 of the Agreement; (g) delivery by Willbros to Cheniere of evidence acceptable to Cheniere that all Subcontractors and Vendors have been fully and finally paid, including fully executed Final Lien and Claim Waivers from all Subcontractors and Major Vendors in the form of Schedule “A”, Attachment X – Part 4 of the Agreement; (h) Willbros has completed all Exception Items in accordance with Paragraph 8.3 of the Agreement; and (i) performance of all other obligations required by the Agreement for Project Completion.

Willbros certifies that it achieved all requirements under the Agreement for Project Completion on \_\_\_\_\_, 200\_.

Attached is all documentation required to be provided by Willbros under the Agreement to establish that Willbros has achieved all requirements under the Agreement for Project Completion, including the required Willbros, Subcontractor, and Major Vendor Lien and Claim Waivers.

**IN WITNESS WHEREOF**, Willbros has caused this Project Completion Certificate to be duly executed by its authorized representative and delivered as of the date first written above.

**WILLBROS ENGINEERS, INC.**

By: \_\_\_\_\_  
Name: \_\_\_\_\_  
Title: Willbros’ Authorized Representative  
Date: \_\_\_\_\_

cc: Cheniere Sabine Pass Pipeline Company  
717 Texas Avenue, Suite 3100  
Houston, Texas 77002  
Attention: Allan Bartz

**ATTACHMENT V**  
**START-UP CERTIFICATE**

Cheniere Sabine Pass Pipeline Company  
717 Texas Avenue, Suite 3100  
Houston, Texas 77002  
Attention: Richard E. Keyser

Re: Start-up Certificate – Sabine Pass Pipeline Project Contract, dated as of February 01, 2006 (the “**Agreement**”), by and between Cheniere Sabine Pass Pipeline Company (“**Cheniere**”) and Willbros Engineers, Inc. (“**Willbros**”)

Pursuant to Paragraph 8.2 of the Agreement, Willbros hereby certifies that it has completed all requirements under the Agreement for Start-up with respect to the Sabine Pass Pipeline Project (“**Project**”), including: (a) the successful achievement of Mechanical Completion of all systems for the Project; (b) Cheniere has purged the Project with either natural gas or nitrogen with assistance and support from Willbros as requested; (c) Willbros has completed all Exception Items in accordance with Paragraph 8.2 of the Agreement; and (d) performance of all other obligations required by the Agreement for Start-up.

Willbros certifies that it achieved all requirements under the Agreement for Start-up on \_\_\_\_\_, 200\_\_.

Attached is all documentation required to be provided by Willbros under the Agreement to establish that Willbros has achieved all requirements under the Agreement for Start-up, including documentation evidencing the completion of all Exception Items required under Paragraph 8.2.

**IN WITNESS WHEREOF**, Willbros has caused this Start-up Certificate to be duly executed by its authorized representative and delivered as of the date first written above.

**WILLBROS ENGINEERS, INC.**

By: \_\_\_\_\_  
Name: \_\_\_\_\_  
Title: Willbros’ Authorized Representative  
Date: \_\_\_\_\_

cc: Cheniere Sabine Pass Pipeline Company  
717 Texas Avenue, Suite 3100  
Houston, Texas 77002  
Attention: Allan Bartz

**ATTACHMENT VI**  
**CHANGE ORDER FORM**

**PROJECT NAME:** 42-inch Sabine Pass Pipeline Project

**COMPANY:** Cheniere Sabine Pass Pipeline Company

**CONTRACTOR:** Willbros Engineers, Inc.

**DATE OF AGREEMENT:** February 01, 2006

**CHANGE ORDER NUMBER:** \_\_\_\_\_

**DATE OF CHANGE ORDER:** \_\_\_\_\_

**The Agreement between the Parties listed above is changed as follows:***(attach additional documentation if necessary)*

**Adjustment to price under the Agreement:**

The original Guaranteed Maximum Price was	\$ 67,670,200
Net change by previously authorized Change Orders (#_____)	\$ _____
The Guaranteed Maximum Price prior to this Change Order was	\$ _____
The Guaranteed Maximum Price will be (increased) (decreased) (unchanged) by this Change Order in the amount of	\$ _____
The new Guaranteed Maximum Price including this Change Order will be	\$ _____

**Adjustment to dates:**

The Preparation and Material Receipt Commencement Date will be (increased)(decreased)(unchanged) by \_\_\_\_\_ (\_\_\_\_) calendar days and as a result of this Change Order is now: \_\_\_\_\_, 20\_\_.

The Construction Commencement Date will be (increased)(decreased)(unchanged) by \_\_\_\_\_ (\_\_\_\_) calendar days and as a result of this Change Order is now: \_\_\_\_\_, 20\_\_.

The Scheduled Mechanical Completion Date will be (increased)(decreased)(unchanged) by \_\_\_\_\_ (\_\_\_\_) calendar days and as a result of this Change Order is now: \_\_\_\_\_, 20\_\_.

Other impacts to liability or obligation of Willbros or Cheniere under the Agreement:

Upon execution of this Change Order by Cheniere and Willbros, the above-referenced change shall become a valid and binding part of the original Agreement without exception or qualification, unless noted in this Change Order. Except as modified by this and any previously issued Change Orders, all other terms and conditions of the Agreement shall remain in full force and effect. This Change Order is executed by each of the Cheniere's Authorized Representative and Willbros' Authorized Representative.

---

**CHENIERE SABINE PASS PIPELINE COMPANY**

---

**WILLBROS ENGINEERS, INC.**

---

Name  
Cheniere's Authorized Representative  
Title

---

Name  
Willbros' Authorized Representative  
Title

---

Date of Signing

---

Date of Signing

---

ATTACHMENT VII

APPROVED SUBCONTRACTORS AND VENDORS LIST

The following Subcontractors and Vendors each having subcontracts or purchase orders of any tier are approved Subcontractors and Vendors for the following portions of the Work:

**I. Subcontractors**

**Construction Subcontractors:**

- Willbros RPI, Inc.
- Sunland Construction, Inc.
- Associated Pipe Line Contractors, Inc.
- Gregory & Cook Construction, Inc.
- U.S. Pipeline, Inc.

**Geotechnical Investigation:**

- Louis J. Capozzoli & Associates, Inc.
- Professional Service Industries, Inc. (PSI)
- Terracon Consultants, Inc.
- Tulonay-Wong Engineers, Inc.

**Cathodic Protection System Design:**

- Corpro Co., Inc.
- Mears/CPG, LLC
- MESA Products, Inc.

**Pipeline Civil Surveying:**

- Charley Foster & Associates
- Lonnie Harper & Associates

**II. Vendors**

**Pipe Mills, DSAW:**

- Oregon Steel-Spiral Weld
- Oregon Steel/Campipe-DSAW Long Seam
- Europipe/Berg

- 
- ILVA (Taranto, Italy)
  - IPSCO, Inc.
  - Corinth Pipe Works S.A. (CPW)

**Pipe Mills, ERW:**

- American Steel Pipe
- Stupp/Manesmann
- LaBarge
- IPSCO, Inc.
- Lone Star

**Valves, Ball Mainline:**

- Cooper-Cameron/Grove/Modern Supply
- Delta Valve (Valvitralia Group-Italy)
- SISCO Specialty Products, Inc.
- Power Valve International

**Valves, Control:**

- Fisher
- Masoneilan

**General Pipe, Valves and Fittings:**

- McJunkin
- Wilson Supply
- Redman Supply

**Bolts, Stud and Gaskets:**

- McJunkin
- Wilson Supply
- Redman Supply

**Fittings and Flanges (Hy Yield):**

- SISCO
- LaBarge
- Wilson Supply

**Bends, Induction:**

- Bend Tec

- 
- Shaw
  - International Piping Systems
  - American Pipe Bending

**Pig Signal:**

- TD Williams

**Launch/Receiver Package:**

- Sagebrush
- Pickett
- Big Inch

**Regulator Package:**

- Sagebrush
- Pickett
- Big Inch



**ATTACHMENT VIII  
ORGANIZATIONAL CHART**

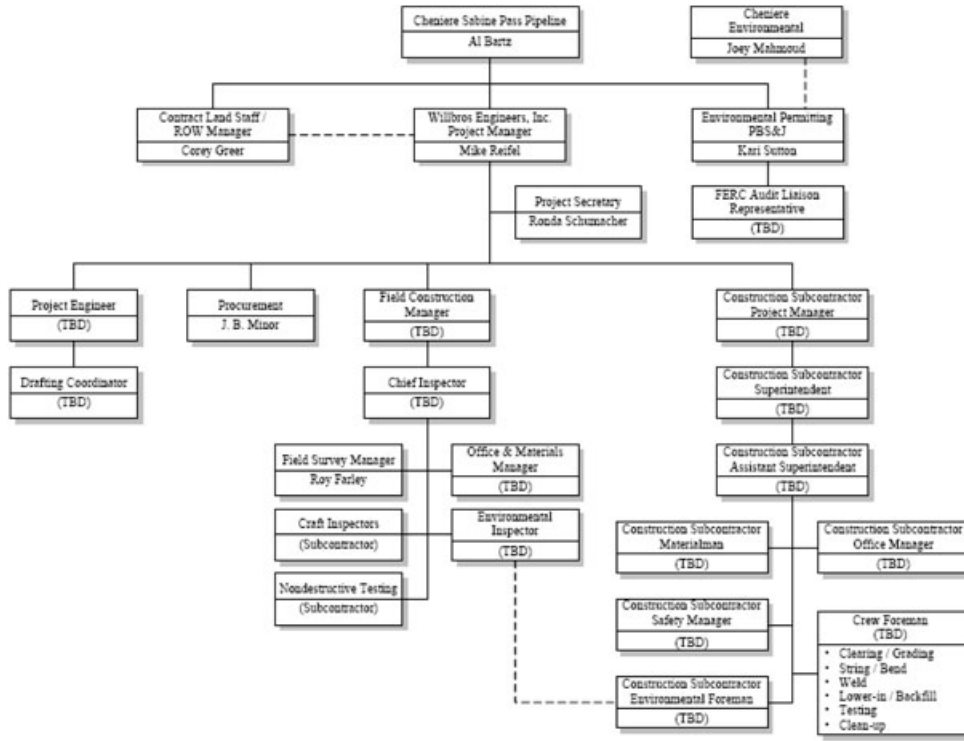

---

**ATTACHMENT IX**

**CHENIERE'S HEALTH, SAFETY AND ENVIRONMENTAL POLICIES**

**1. General Guidelines**

Health, safety and safeguarding of the environment are within Cheniere's core values. Willbros shall take into consideration health, safety and the environment ("HSE") throughout execution of the Work.

The minimum approach to the management of HSE issues is generally described in this Attachment IX, and Willbros shall comply with such minimum requirements and, to the extent possible, maintain the highest level of HSE stewardship for Work of this nature during the execution of the Work. At a minimum, the Work and Willbros' HSE activities and plans shall comply with: (i) all Applicable Codes and Standards; (ii) all Applicable Laws, including 29 C.F.R. Part 1910, CERCLA, SARA, and all other applicable environmental laws, regulations and requirements; (iii) the FERC Certificate, and (iv) the most current FERC-authorized Wetland and Waterbody Construction and Mitigation Procedures and the Upland Erosion Control, Re-vegetation, and Maintenance Plan.

**2. Safety Management**

Cheniere's general HSE policies shall apply to Willbros and its Subcontractors and Vendors performing Work at the Work Site, and shall apply to the fullest extent practical at all other sites where Work is being performed for Cheniere or where Cheniere personnel are involved.

Willbros shall pay the highest regard to safety and shall conform to all safety-related requirements set forth in the Agreement, including this Attachment IX and Schedule "D".

Willbros shall be responsible for the safe performance of the Work under the Agreement, including: (i) the safety of all of the employees, agents, representatives and invitees of Willbros and its Subcontractors and Vendors engaged in the performance of the Work; (ii) ensuring that all Willbros Personnel are familiar with and will apply all applicable HSE rules and regulations; (iii) providing safety incident reports to Cheniere in accordance with the Agreement; (iv) providing a safe working environment at the Work Site; (v) the safe performance of the Work by all Willbros Personnel; and (vi) ensuring that awareness of the importance of safety is actively promoted at the Work Site.

**3. Environmental Management**

Willbros shall pay the highest regard to protection of the environment and shall carry out environmental management to ensure that the Work is performed in an environmentally sound manner and in compliance with all provisions of the Agreement, including this Attachment IX, regarding the environment and Applicable Law.

---

Willbros' objective shall be to ensure, through the proper application of its environmental protection procedures, that the Work is: (i) managed, planned and engineered to minimize any impact upon the environment; (ii) performed and completed without incidents detrimental to the environment; and (iii) performed in full compliance with the environmental policy objectives.

**4. Willbros HSE Plan**

Willbros shall incorporate all health, safety and environmental requirements of the Agreement, including this Attachment IX, into Willbros' HSE plan which it shall implement and adhere to during the performance of the Work.

Willbros HSE plan shall contain a full description of the safety and environmental rules, procedures, guidelines, and Work instructions applicable at the Work Site, which Willbros shall use to ensure the safe and environmentally friendly management of the Work. The HSE plan shall cover all phases of the Work and all activities through Final Acceptance and shall specifically describe safety and environmental management at the Work Site.

The HSE plan shall address all safety and environmental matters relevant to the Work, including the following: (i) safety meetings and safety events; (ii) safety inspections; (iii) training schedule; (iv) safety reviews at the Work Site; (v) construction safety reviews; (vi) all reasonable emergency response plans, medical emergency plans; (vii) plans to control the possession and use of firearms, alcohol and controlled substances; and (viii) a Spill Prevent, Control and Countermeasure (SPCC) plan.

Cheniere, at its sole discretion, may audit Willbros' performance of the Work to ensure that the Agreement requirements for safety and the environment are being satisfied in all respects. Any audits performed shall be based upon Willbros' safety and environmental manual(s), procedures, and plans. Willbros, at its sole cost, shall immediately correct any nonconformance identified by Cheniere or its auditors.

ATTACHMENT X – PART 1

WILLBROS' INTERIM LIEN AND CLAIM WAIVER  
(To be executed by Willbros with each invoice other than the final invoice)

STATE OF LOUISIANA  
PARISH OF \_\_\_\_\_

The undersigned, Willbros Engineers, Inc. ("Willbros"), has been engaged under a Pipeline Construction Contract with Cheniere Sabine Pass Pipeline Company ("Cheniere"), to furnish certain materials, equipment, services, and/or labor for the project known as 42-inch Sabine Pass Pipeline Project (the "Project"), which is located in Cameron Parish, State of Louisiana described in more detail as follows:

\_\_\_\_\_ (the "Property").

Upon receipt of the sum of U.S.\$ \_\_\_\_\_ (amount in invoice submitted with this Interim Lien and Claim Waiver), Willbros waives and releases any and all liens or claims of liens against the Project and the Property and all claims, demands, actions, causes of actions or other rights at law, in contract, tort, equity or otherwise that Willbros has or may have against Cheniere through the date of \_\_\_\_\_, 20\_\_ (date of the invoice submitted with this Interim Lien and Claim Waiver). Exceptions as follows:

\_\_\_\_\_  
(if no exception entry or "none" is entered above, Willbros shall be deemed not to have reserved any claim.)

Willbros represents that all Subcontractors, Vendors, sub-subcontractors and employees of Willbros have been paid for all work, materials, equipment, services, labor and any other items performed or provided through \_\_\_\_\_, 20\_\_ (date of last prior invoice) for the Project. Exceptions as follows:

\_\_\_\_\_  
(if no exception entry or "none" is entered above, all such payments have been made)

This Interim Lien and Claim Waiver is freely and voluntarily given and Willbros acknowledges and represents that it has fully reviewed the terms and conditions of this Interim Lien and Claim Waiver, that it is fully informed with respect to the legal effect of this Interim Lien and Claim Waiver, that it has voluntarily chosen to accept the terms and conditions of this Interim Lien and Claim Waiver in return for the payment recited above.

**FOR WILLBROS:**

Applicable to Invoice(s) No. \_\_\_\_\_

Signed: \_\_\_\_\_ (SEAL)  
By: \_\_\_\_\_  
Title: \_\_\_\_\_  
Date: \_\_\_\_\_

**AFFIDAVIT**

On this \_\_ day of \_\_\_\_\_, 20\_\_, before me appeared the above-signed, known or identified to me personally, who, being first duly sworn, did say that s/he is the authorized representative of Willbros and that this document was signed under oath personally and on behalf of Willbros.

\_\_\_\_\_  
Notary Public  
My term expires (date): \_\_\_\_\_

ATTACHMENT X – PART 2

WILLBROS' FINAL LIEN AND CLAIM WAIVER  
(To be executed by Willbros with the invoice for final payment)

STATE OF LOUISIANA  
PARISH OF \_\_\_\_\_

The undersigned, Willbros Engineers, Inc. ("Willbros"), has been engaged under an agreement with Cheniere Sabine Pass Pipeline Company ("Cheniere"), to furnish certain materials, equipment, services, and/or labor for the project known as the 42-inch Sabine Pass Pipeline Project ("Project"), which is located in Cameron Parish, State of Louisiana and more particularly described as follows:

\_\_\_\_\_ (the "Property").

Upon receipt of the sum of U.S.\$ \_\_\_\_\_ (amount in invoice for final payment submitted with Willbros' Final Lien and Claim Waiver), Willbros waives and releases all liens or claims of liens against the Project and the Property and all claims, demands, actions, causes of actions or other rights at law, in contract, tort, equity or otherwise that Willbros has, may have had or may have in the future against Cheniere arising out of the agreement or the Project, whether or not known to Willbros at the time of the execution of this Final Lien and Claim Waiver.

Willbros represents that all of its obligations, legal, equitable, or otherwise, relating to or arising out of its work on the agreement, Project or subcontracts have been fully satisfied (except for that work and obligations that survive the termination or expiration of the agreement, including warranties and correction of defective services), including, but not limited to payment to Subcontractors, Vendors and employees and payment of taxes.

This Final Lien and Claim Waiver is freely and voluntarily given, and Willbros acknowledges and represents that it has fully reviewed the terms and conditions of this Final Lien and Claim Waiver, that it is fully informed with respect to the legal effect of this Final Lien and Claim Waiver, and that it has voluntarily chosen to accept the terms and conditions of this Final Lien and Claim Waiver in return for the payment recited above. Willbros understands, agrees and acknowledges that, upon payment, this document waives rights unconditionally and is fully enforceable to extinguish all claims of Willbros as of the date of execution of this document by Willbros.

**FOR WILLBROS:**

Applicable to Invoice No(s): ALL (If all, print "all")

Signed: \_\_\_\_\_ (SEAL)  
By: \_\_\_\_\_  
Title: \_\_\_\_\_  
Date: \_\_\_\_\_

**AFFIDAVIT**

On this \_\_\_ day of \_\_\_\_\_, 20\_\_\_, before me appeared the above-signed, known or identified to me personally, who, being first duly sworn, did say that s/he is the authorized representative of Willbros and that this document was signed under oath personally and on behalf of Willbros.

\_\_\_\_\_  
Notary Public  
My term expires (date): \_\_\_\_\_

ATTACHMENT X – PART 3

SUBCONTRACTORS' INTERIM LIEN AND CLAIM WAIVER

(To be executed by Subcontractor or Major Vendor [as applicable] with each invoice other than the final invoice)

STATE OF LOUISIANA
PARISH OF \_\_\_\_\_

The undersigned, \_\_\_\_\_ ("Subcontractor") who has, under an agreement with Willbros Engineers, Inc. ("Willbros"), furnished certain materials, equipment, services, and/or labor for the project known as the 42-inch Sabine Pass Pipeline Project (the "Project"), which is located in Cameron Parish, State of Louisiana described in more detail as follows:

\_\_\_\_\_ (the "Property").

Upon receipt of the sum of U.S.\$ \_\_\_\_\_ ("Current Payment"), Subcontractor waives and releases any and all liens or claims of liens against the Project and the Property and all claims, demands, actions, causes of action or other rights at law, in contract, tort, equity or otherwise that Subcontractor has or may have against Cheniere Sabine Pass Pipeline Company ("Cheniere") and Willbros through the date of \_\_\_\_\_, 20\_\_\_\_ ("Current Date"). Exceptions as follows:

\_\_\_\_\_ (if no exception entry or "none" is entered above, Subcontractor shall be deemed not to have reserved any claim.)

Subcontractor further represents that all employees, laborers, materialmen, sub-subcontractors and subconsultants employed by Subcontractor in connection with the Project have been paid for all work, materials, equipment, services, labor and any other items performed or provided through \_\_\_\_\_, 20\_\_\_\_ (date of last prior Invoice). Exceptions as follows:

\_\_\_\_\_ (if no exception entry or "none" is entered above, all such payments have been made)

This Subcontractor's Interim Lien and Claim Waiver is freely and voluntarily given and Subcontractor acknowledges and represents that it has fully reviewed the terms and conditions of this Subcontractor's Interim Lien and Claim Waiver, that it is fully informed with respect to the legal effect of this Subcontractor's Interim Lien and Claim Waiver, that it has voluntarily chosen to accept the terms and conditions of this Subcontractor's Interim Lien and Claim Waiver in return for the payment recited above.

FOR SUBCONTRACTOR :

Applicable to Invoice(s) No. \_\_\_\_\_

Signed: \_\_\_\_\_ (SEAL)

By: \_\_\_\_\_

Title: \_\_\_\_\_

Date: \_\_\_\_\_

AFFIDAVIT

On this \_\_\_\_ day of \_\_\_\_\_, 20\_\_, before me appeared the above-signed, known or identified to me personally, who, being first duly sworn, did say that s/he is the authorized representative of Subcontractor and that this document was signed under oath personally and on behalf of Subcontractor.

\_\_\_\_\_  
Notary Public  
My term expires (date): \_\_\_\_\_

ATTACHMENT X – PART 4

SUBCONTRACTORS' FINAL LIEN AND CLAIM WAIVER

(To be executed by Subcontractor or Major Vendor [as applicable] with the invoice for final payment)

STATE OF LOUISIANA
PARISH OF \_\_\_\_\_

The undersigned, \_\_\_\_\_ ("Subcontractor"), has, under an agreement with Willbros Engineers, Inc. ("Willbros"), furnished certain materials, equipment, services, and/or labor for the Project known as the 42-inch Sabine Pass Pipeline Project ("Project"), which is located in Cameron Parish, State of Louisiana and more particularly described as follows:

\_\_\_\_\_ (the "Property").

Upon receipt of the sum of U.S.\$ \_\_\_\_\_, Subcontractor waives and releases any and all liens or claims of liens against the Project and the Property, all claims, demands, actions, causes of action or other rights at law, in contract, tort, equity or otherwise against Cheniere Sabine Pass Pipeline Company ("Cheniere") or Willbros, and any and all claims or rights against any labor and/or material bond, which Subcontractor has, may have had or may have in the future arising out of the agreement between Subcontractor and Willbros, the Project or the Property, whether or not known to Subcontractor at the time of the execution of this Subcontractor's Final Lien and Claim Waiver.

Subcontractor represents that all of its obligations, legal, equitable, or otherwise, relating to or arising out of the agreement between Willbros and Subcontractor, the Project, the Property or sub-subcontracts have been fully satisfied (except for that work and obligations that survive the termination or expiration of the agreement between Subcontractor and Willbros, including warranties and correction of defective services), including, but not limited to payment to sub-subcontractors and employees of Subcontractor and payment of taxes.

This Subcontractor's Final Lien and Claim Waiver is freely and voluntarily given and Subcontractor acknowledges and represents that it has fully reviewed the terms and conditions of this Subcontractor's Final Lien and Claim Waiver, that it is fully informed with respect to the legal effect of this Subcontractor's Final Lien and Claim Waiver, and that it has voluntarily chosen to accept the terms and conditions of this Subcontractor's Final Lien and Claim Waiver in return for the payment recited above. Subcontractor understands, agrees and acknowledges that, upon payment, this document waives rights unconditionally and is fully enforceable to extinguish all claims of Subcontractor as of the date of execution of this document by Subcontractor.

FOR SUBCONTRACTOR:

Applicable to Invoice No(s). ALL (If all, print "all")

Signed: \_\_\_\_\_ (SEAL)

By: \_\_\_\_\_

Title: \_\_\_\_\_

Date: \_\_\_\_\_

AFFIDAVIT

On this \_\_\_\_ day of \_\_\_\_\_, 20\_\_, before me appeared the above-signed, known or identified to me personally, who, being first duly sworn, did say that s/he is the authorized representative of Subcontractor and that this document was signed under oath personally and on behalf of Subcontractor.

Notary Public
My term expires (date): \_\_\_\_\_

---

**SCHEDULE "B"**

**SCOPE OF WORK FOR THE PROJECT**

**TABLE OF CONTENTS**

1. PROJECT MANAGEMENT AND ENGINEERING	B-2
2. MATERIAL PROCUREMENT	B-3
3. CONSTRUCTION MANAGEMENT	B-4
4. CONSTRUCTION	B-5
5. DELIVERABLES	B-6
ATTACHMENT I WORK SITE	B-7
ATTACHMENT II FLOW SCHEMATIC	B-8



**SCHEDULE "B"**

**SCOPE OF WORK FOR THE PROJECT**

Willbros shall perform the Project management, engineering, material procurement, construction management and construction for the Project as described in the Agreement and herein, including providing all deliverables described below.

**1. PROJECT MANAGEMENT AND ENGINEERING**

A Willbros project manager shall provide management and direction for the Project. Project controls shall maintain a detailed Work Plan with activities planned for the Work as set forth in Paragraph 6 of Schedule "A". Following construction, Willbros will assemble completion report data, hydrostatic test records, non-destructive testing records, internal geometry pig results, Vendor data and material certifications, MAOP establishment records, and other inspection certificates.

Without limiting the generality of the foregoing, the Project management and engineering portion of the Work to be performed by Willbros shall include:

1.1 Perform Project management, controls and reporting;

1.2 Prepare design basis document using the following design parameters:

Class Locations (to be field verified)	
Class 1	MP 0 to MP 11
Class 3	MP 11 to MP 16
Design Pressure, psig	1440
Operating Temperature, °F	20 - 100
Corrosion Allowance, inches	nil
Pipe Diameter, inches	42
Pipe W.T. and Grade	
F = 0.72	0.600" API 5L - X70
F = 0.60	0.700" API 5L - X70
F = 0.50	0.864" API 5L - X70
External Coatings	
FBE	14 - 16 mils
Ruff Coat or equal (for concrete coated pipe)	3 - 5 mils (in addition to FBE)
Abrasion Resistant Coating (for road bores)	32 mils
Internal Liquid Epoxy Coating	1.5 mils
Minimum Bend Radius for Pigging	5 pipe diameters
Concrete Weight Coating	6" thick, 190 pcf (0.600" W.T. pipe) 5" thick, 190 pcf (0.864" W.T. pipe)

1.3 Perform population density analysis to finalize class locations;

- 
- 1.4 Perform field reconnaissance and gather site specific data at appurtenance locations and crossings, including foreign pipeline crossings;
  - 1.5 Provide engineering input for permit applications, in accordance with Paragraph 2.3 of Schedule "A";
  - 1.6 Perform detailed design of the pipeline and all ancillary facilities of the Project, with reference to the flow schematic located in Attachment II;
  - 1.7 Prepare Drawings and Specifications with bills-of-materials and construction typicals, in accordance with the Agreement, including Schedule "D", and Paragraphs 2.7 and 2.8 of Schedule "A";
  - 1.8 Modify, as required and in accordance with this Agreement, the Cheniere-provided drawings listed in Paragraph 5.3 of Schedule "A".
  - 1.9 Perform geotechnical investigations at monitor-regulator and scraper launcher site;
  - 1.10 Perform cathodic protection system design;
  - 1.11 Prepare construction Specifications with hydrostatic test plan, in accordance with Schedule "D";
  - 1.12 Prepare job data books which will including hydrostatic test records, welding records, as-built Drawings, certified Vendor Drawings, material certifications, operating and maintenance instructions for purchased equipment, spare parts lists, Warranties, as-built survey data and results of the internal geometry pig results in an electronic format compatible with the GIS of Cheniere's choice;
  - 1.13 Provide engineering support during construction, commissioning and Start-up of the Project; and
  - 1.14 Prepare construction bid solicitation packages, solicit bids, analyze bids and award construction Work to a bidder , in accordance with Paragraphs 3.3, 3.4, and 3.5 of Schedule "A".

## **2. MATERIAL PROCUREMENT**

The procurement portion of the Work to be performed by Willbros shall include:

- 2.1 Develop major material Specifications, in accordance with Schedule "D", and solicit and evaluate bids for such materials;
- 2.2 Issue purchase orders for all permanent materials and provide shipping instructions to Vendors;
- 2.3 Expedite and coordinate material shipments;
- 2.4 Review and approve Vendor Drawings and data submittals;
- 2.5 Obtain material certification records;
- 2.6 Process material receiving reports and Vendor invoices;

- 
- 2.7 Make timely and appropriate payments to Vendors;
  - 2.8 Perform the following inspections at the Vendor's plant before material shipment:
    - 2.8.1 Pipe mill (review manufacturing procedures, attend pre-production meeting, and perform inspections during pipe manufacturing);
    - 2.8.2 Fusion-bonded epoxy coating;
    - 2.8.3 Concrete coating;
    - 2.8.4 Launcher skid; and
    - 2.8.5 Monitor regulator skid;
  - 2.9 Receive, inspect and inventory materials at the Work Site; and
  - 2.10 Provide recommended spare parts list for commissioning, operations and maintenance (spare parts may, at Cheniere's sole discretion, be purchased by Cheniere); the cost of such spare parts is not included within the Guaranteed Maximum Price.

### **3. CONSTRUCTION MANAGEMENT**

A field office staffed with Willbros Personnel including a field project manager, an office manager/assistant will be established at the Work Site in the Johnson's Bayou area, in accordance with Paragraph 4.2 of Schedule "A". Inspection services will be subcontracted to a qualified firm or self-performed by Willbros in accordance with Paragraph 7 of Schedule "A". The construction survey will include a 5-man crew for construction staking and a 2-man and 3-man crew for as-built surveys. These crews will be supervised by Willbros' chief supervisor.

Without limiting the generality of the foregoing, the construction management portion of the Work to be performed by Willbros shall include:

- 3.1 Prepare digital alignment maps, showing the pipeline centerline, property ownership and land base information;
- 3.2 Prepare road crossing permit Drawings;
- 3.3 Perform pre-construction staking for the pipeline, including sites for scraper launcher, monitor regulator station, side valves, mainline valves and other pipeline appurtenances;
- 3.4 Perform pre- and post-construction topographic civil surveys of the wetlands crossed within the pipeline right-of-way between stations 62+35 and 480+34 to confirm ground contour restoration at the conclusion of construction is in accordance with the FERC certificate. The surveys will be conducted at the time of restoration and used to ensure compliance prior to demobilization of the construction Subcontractor. Drawing exhibits with the location of the surveys and cross-sections of the pre- and post-construction transects will be prepared. The pre- and post-construction ground elevation tolerance shall be minus zero (0), plus six (6) inches;

- 
- 3.5 Perform as-built surveys and prepare as-built Drawings following construction in accordance with Schedule "D" and Paragraphs 2.7 and 2.8 of Schedule "A". All survey information shall be geo-referenced. Survey data processing will be performed so that all data collected is delivered in an electronic format compatible with the GIS of Cheniere's choice;
  - 3.6 Perform construction inspection through a qualified independent third party to ensure that construction meets the requirements of the Specifications, Drawings, easements, Applicable Law, Applicable Codes and Standards, permit provisions and all other requirements of construction included in the Agreement; and
  - 3.7 Provide commissioning and Start-up support, as required by Cheniere, excluding gas handling services.

#### 4. CONSTRUCTION

The construction portion of the Work to be performed by Willbros or its Subcontractors shall include:

- 4.1 Perform pipeline construction, including clearing, grading, stringing, bending, ditching, laying, welding, coating, tie-ins, lowering-in, backfilling, testing and cleanup;
- 4.2 Install pipeline monitor regulator station, pig launcher, side valves, mainline valves, and pipeline appurtenances (CP test stations and line markers). The outlet end of the pipeline will have a weld cap with 2-inch coupling, nipple, plug valve and plug;
- 4.3 Perform internal geometry pig survey on the completed pipeline construction prior to the introduction of natural gas or nitrogen to verify that there are no dents with dimensions greater than what 49 C.F.R. Part 192 or ASME B31.8 codes allow;
- 4.4 Install pre-fabricated assemblies, including:
  - 4.4.1 Monitor-regulator station (skid-mounted) on pile-supported platform;
  - 4.4.2 Pig launcher (skid-mounted) on pile-supported platform; and
  - 4.4.3 30-inch NGPL side tap;
  - 4.4.4 42-inch mainline valve assembly; and
  - 4.4.5 42-inch mainline valve and 42-inch side valve;
- 4.5 De-water, clean and dry the interior of the pipeline using a series of displacement and cleaning pigs propelled by dry air to achieve a dew point of negative forty degrees Fahrenheit (-40°F) or less. After drying, the pipeline will be shut-in and pressurized to five (5) psig with dry air.
- 4.6 Tie-in pipeline to liquefied natural gas terminal at launcher site; tie-in at Johnson's Bayou will be by others;
- 4.7 Perform site Work at the Work Site, including installation of chain link fence with drive-through and walk gates, grading and installation of rock;

- 
- 4.8 Perform Non-destructive testing (NDT) through a qualified third party inspector; radiography inspection shall be performed on 100-percent of girth welds, and a NDT auditor shall be required; and
  - 4.9 Cheniere shall provide Willbros access to and use of Cheniere's dock at the liquefied natural gas terminal for offloading pipe and major equipment skids from barges. Cheniere shall also provide access to and use of a yard at the liquefied natural gas terminal for staging and pipe storage. Willbros may, with Cheniere's prior written approval, use an alternate docking facility and/or yard in the Work Site.

### **5. DELIVERABLES**

The following deliverables are considered part of the Work and shall be provided by Willbros during the development and execution of the Project:

- 5.1 Drawings (refer to Attachment I of Schedule "D")
- 5.2 Specifications (refer to Attachment II of Schedule "D")
- 5.3 Job Data Book
  - 5.3.1 Hydrostatic tests
  - 5.3.2 Material purchase orders
  - 5.3.3 Material certifications
  - 5.3.4 Certified Vendor Drawings
  - 5.3.5 Operating and maintenance instructions for purchased equipment
  - 5.3.6 Spare parts lists
  - 5.3.7 Warranties
  - 5.3.8 As-built Drawings (with GIS compatible data)
  - 5.3.9 Welder qualifications
  - 5.3.10 Welding procedure(s)
  - 5.3.11 Weld records summary
  - 5.3.12 Internal geometry pig results (with GIS compatible data)
- 5.4 Administrative
  - 5.4.1 Monthly progress and cost status reports
  - 5.4.2 Monthly Project Schedule updates
  - 5.4.3 Monthly procurement status reports
  - 5.4.4 Meeting notes

**ATTACHMENT I**

**WORK SITE**



Proposed 42" Natural Gas Pipeline Project  
Sabine Pass Pipeline Project

**ATTACHMENT II**

**FLOW SCHEMATIC**

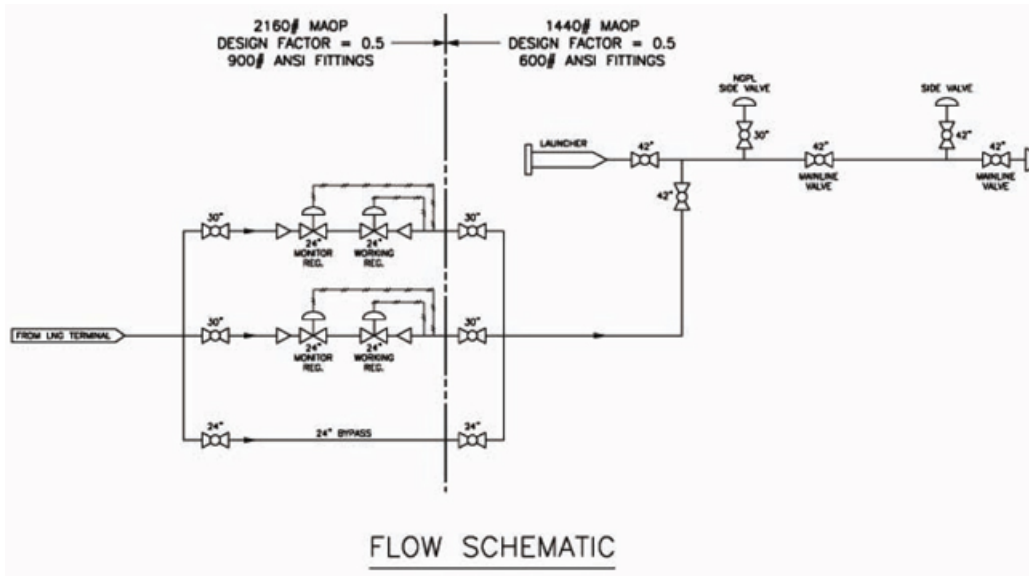

---

**SCHEDULE "C"**

*INTENTIONALLY OMITTED*

C-1



---

**SCHEDULE "D"**

**APPLICABLE CODES AND STANDARDS, DRAWINGS AND  
SPECIFICATIONS**

**TABLE OF CONTENTS**

1. APPLICABLE CODES AND STANDARDS	D-2
2. DRAWINGS	D-3
3. SPECIFICATIONS	D-3
ATTACHMENT I DRAWINGS	D-4
ATTACHMENT II SPECIFICATIONS	D-5

---

**SCHEDULE "D"**

**APPLICABLE CODES AND STANDARDS, DRAWINGS AND SPECIFICATIONS**

**1. APPLICABLE CODES AND STANDARDS**

During the execution of the Work, Willbros shall comply with the latest edition of the following Applicable Codes and Standards, irrespective of the specification of any earlier date or edition. In the event of a conflict between the Applicable Codes and Standards and the Specifications, Willbros shall promptly notify Cheniere of the conflict. The specific Applicable Codes and Standards listed in this Schedule with respect to each organization (e.g., API) are not meant to be an exclusive list of such Applicable Codes and Standards that must be adhered to with respect to each such organization as they are applicable to the Work.

The Project and all related facilities will be designed in accordance with Part 192, Title 49 of the Code of Federal Regulations "Transportation of Natural and Other Gas By Pipeline: Minimum Federal Safety Standards" (latest edition).

AASHTO	American Association of State Highway and Transportation Officials
AISC	American Institute of Steel Construction
ANSI	American National Standards Institute
API	American Petroleum Institute
ASCE	American Society of Civil Engineers
ASME	American Society of Mechanical Engineers
ASTM	American Society of Testing and Materials
AWS	American Welding Society
EPA	Environmental Protection Agency
FM	Factory Mutual
IEEE	Institute of Electrical and Electronics Engineers
IES	Illuminated Engineering Society
ISA	Instrument Society of America
MSS	Manufacturers Standardization Society of the Valve and Fitting Industry
NACE	National Association of Corrosion Engineers
NEMA	National Electrical Manufacturers Association
NFPA	National Fire Protection Association
OSHA	Occupational Safety and Health Act
UBC	Uniform Building Code
UL	Underwriters Laboratories
NEC	National Electrical Code (NFPA 70)

---

## **2. DRAWINGS**

Willbros shall provide the Drawings listed in Attachment I of this Schedule "D" in accordance with this Agreement.

## **3. SPECIFICATIONS**

The Specifications include the material/equipment specifications, design specifications, construction specifications, and inspection specifications included in Attachment II of this Schedule "D".

END OF SCHEDULE "D"

---

**ATTACHMENT I**

**DRAWINGS**

1. FERC Alignment Sheets
2. Construction Alignment Drawings
3. As-Built Alignment Drawings
4. Highway Crossing Plan/Profile
5. Typical Parish Road Crossing
6. Site Specific Wetland Construction Plan
7. Hydrostatic Test Profile
8. Foreign Pipeline Crossings
9. Construction Typicals
10. Notes and Legend Sheet
11. Scraper Launcher and Inlet Pressure Regulator Plot Plan
12. Side Valve Plan and Elevation
13. Mainline Valve Plan and Elevation
14. Scraper Launcher and Monitor Regulator Platforms
15. Pile and Pile Cap Details and Plot Plans
16. Fence Standard
17. Monitor Regulator Skid Layout
18. Scraper Launcher Skid Layout
19. Scraper Launcher Piping Hookup Details
20. Monitor Regulator Piping Hookup Details
21. Pipeline System P&ID
22. Valve Operator Details

---

**ATTACHMENT II**  
**SPECIFICATIONS**

1. Submerged Arc Welded Line Pipe Longitudinal Seam
2. Submerged Arc Welded Line Pipe Helical Seam
3. Stock Pipe Seamless, SAW and ERW
4. Handling, Storage and Shipment of Line Pipe
5. Yard Applied Pipe Coating
6. Yard Application of Concrete Coating to Pipe
7. Internal Coating of Line Pipe
8. Induction Bending of Line Pipe
9. High Strength Wrought Welding Fittings
10. Application of Protective Coating Systems
11. Valve Procurement (API 6D, 12-inch and larger)
12. Pneumatic Quarter Turn Valve Operators
13. Pressure Regulation Valves
14. Line Pipe Inspection
15. Geotechnical Investigation
16. Construction of Pipeline and Related Facilities
17. Hydrostatic Test Plan
18. Welding Procedures
19. As-Built Survey Procedure

---

**SCHEDULE "E"**

*INTENTIONALLY OMITTED*

---

**SCHEDULE "F"**

**PROJECT SCHEDULE**

F-1





**SCHEDULE F  
PROJECT SCHEDULE**

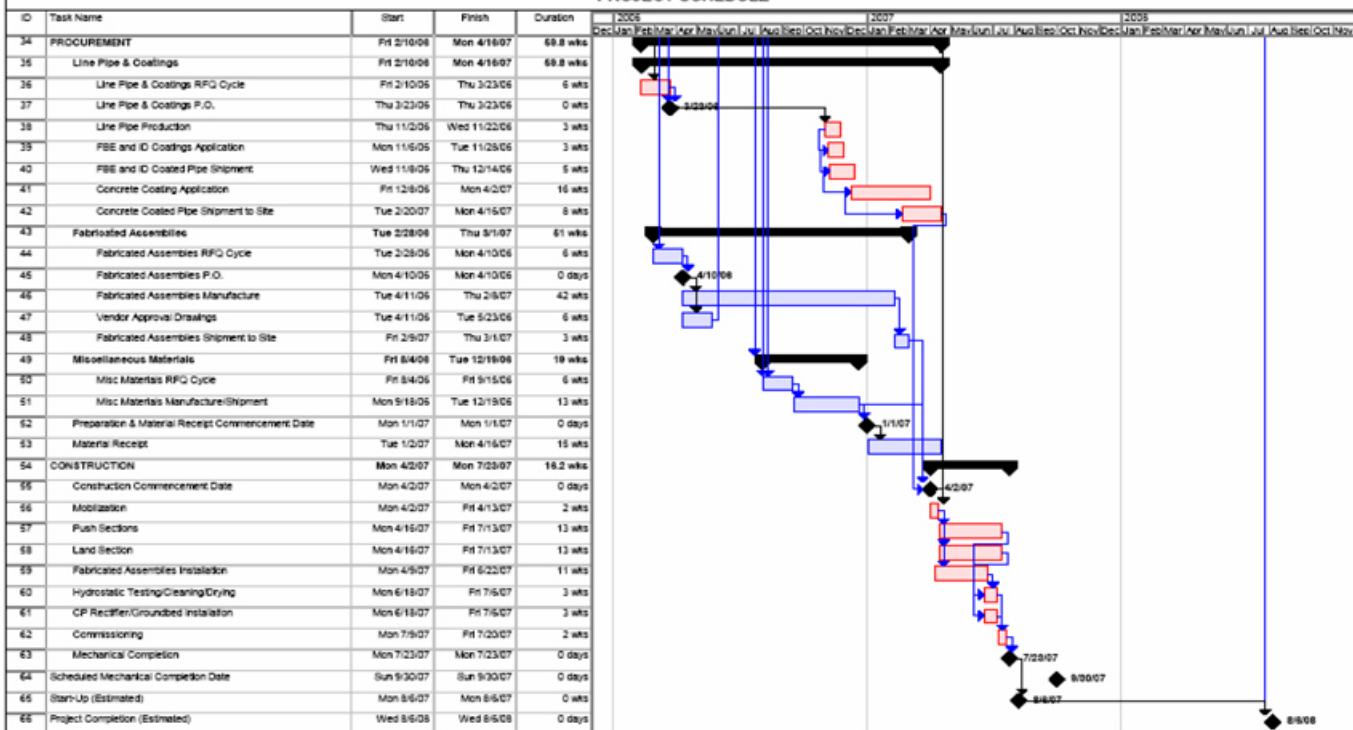

By: Wilross Engineers, Inc.  
Date: January 23, 2006



Task		Progress		Project Summary		Deadline	
Split		Milestone		External Tasks			
Project Guide: Critical		Summary		External Milestone			

## SUBSIDIARIES

Name of Subsidiary	Jurisdiction of Organization	Assumed Names
Cheniere LNG Financial Services, Inc.	Delaware	None
Cheniere LNG Holdings, LLC	Delaware	None
Cheniere LNG-LP Interests, LLC	Delaware	None
Sabine Pass LNG, L.P.	Delaware	None
Sabine Pass LNG-LP, LLC	Delaware	None
Cheniere LNG Terminals, Inc.	Delaware	None
Cheniere LNG, Inc.	Delaware	None

**CONSENT OF INDEPENDENT REGISTERED PUBLIC ACCOUNTING FIRM**

We hereby consent to the incorporation by reference in the Registration Statements on Form S-3 (Nos. 333-57533, 333-49847, 333-70195, 333-83949, 333-94841, 333-61238, 333-71496, 333-105295, 333-114006, 333-111454 and 333-127269 (including any amendments thereto)) and on Form S-8 (Nos. 333-52479, 333-35868, 333-112379, 333-35866, 333-111457, 333-118816 and 333-127266 (including any amendments thereto)) of Cheniere Energy, Inc. of our reports dated March 10, 2006 relating to the consolidated financial statements of Cheniere Energy, Inc., Cheniere Energy, Inc.'s management assessment of the effectiveness of internal control over financial reporting, and the effectiveness of internal control over financial reporting of Cheniere Energy, Inc., which appear in this Annual Report on Form 10-K on pages 74 and 75.

/s/ UHY MANN FRANKFORT STEIN & LIPP CPAs, LLP

---

UHY MANN FRANKFORT STEIN & LIPP CPAs, LLP

Houston, Texas  
March 10, 2006

**CONSENT OF INDEPENDENT REGISTERED PUBLIC ACCOUNTING FIRM**

We hereby consent to the incorporation by reference in the Registration Statements on Form S-3 (Nos. 333-57533, 333-49847, 333-70195, 333-83949, 333-94841, 333-61238, 333-71496, 333-105295, 333-114006, 333-111454 and 333-127269 (including any amendments thereto)) and on Form S-8 (Nos. 333-52479, 333-35868, 333-112379, 333-35866, 333-111457, 333-118816 and 333-127266 (including any amendments thereto)) of Cheniere Energy, Inc. of our report dated February 16, 2006 relating to the financial statements of Freeport LNG Development, L.P., which appears in this Annual Report on Form 10-K on page 125.

/s/ HEIN & ASSOCIATES LLP

---

HEIN & ASSOCIATES LLP

Dallas, Texas  
March 8, 2006

**CONSENT OF INDEPENDENT PETROLEUM ENGINEERS**

We hereby consent to the incorporation by reference in the Registration Statements on Form S-3 (Nos. 333-57533, 333-49847, 333-70195, 333-83949, 333-94841, 333-61238, 333-71496, 333-105295, 333-114006, 333-111454 and 333-127269 (including any amendments thereto)) and on Form S-8 (Nos. 333-52479, 333-35868, 333-112379, 333-35866, 333-111457, 333-118816 and 333-127266 (including any amendments thereto)) of Cheniere Energy, Inc. of our reserve reports, which appear in this Annual Report on Form 10-K.

/s/ SHARP PETROLEUM ENGINEERING, INC.

---

SHARP PETROLEUM ENGINEERING, INC.

Houston, Texas  
March 4, 2006

**CERTIFICATION BY CHIEF EXECUTIVE OFFICER PURSUANT TO  
RULE 13a-14(a) AND 15d-14(a) UNDER THE EXCHANGE ACT**

I, Charif Souki, certify that:

1. I have reviewed this annual report on Form 10-K of Cheniere Energy, Inc.;
2. Based on my knowledge, this report does not contain any untrue statement of a material fact or omit to state a material fact necessary to make the statements made, in light of the circumstances under which such statements were made, not misleading with respect to the period covered by this report;
3. Based on my knowledge, the financial statements, and other financial information included in this report, fairly present in all material respects the financial condition, results of operations and cash flows of the registrant as of, and for, the periods presented in this report;
4. The registrant's other certifying officers and I are responsible for establishing and maintaining disclosure controls and procedures (as defined in Exchange Act Rules 13a-15(e) and 15d-15(e)) and internal control over financial reporting (as defined in Exchange Act Rules 13a-15(f) and 15d-15(f)) for the registrant and have:
  - a) Designed such disclosure controls and procedures, or caused such disclosure controls and procedures to be designed under our supervision, to ensure that material information relating to the registrant, including its consolidated subsidiaries, is made known to us by others within those entities, particularly during the period in which this report is being prepared;
  - b) Designed such internal control over financial reporting, or caused such internal control over financial reporting to be designed under our supervision, to provide reasonable assurance regarding the reliability of financial reporting and the preparation of financial statements for external purposes in accordance with generally accepted accounting principles;
  - c) Evaluated the effectiveness of the registrant's disclosure controls and procedures and presented in this report our conclusions about the effectiveness of the disclosure controls and procedures, as of the end of the period covered by this report based on such evaluation;
  - d) Disclosed in this report any change in the registrant's internal control over financial reporting that occurred during the registrant's most recent fiscal quarter (the registrant's fourth fiscal quarter in the case of an annual report) that has materially affected, or is reasonably likely to materially affect, the registrant's internal control over financial reporting; and
5. The registrant's other certifying officers and I have disclosed, based on our most recent evaluation of internal control over financial reporting, to the registrant's auditors and the audit committee of the registrant's board of directors (or persons performing the equivalent functions):
  - a) All significant deficiencies and material weaknesses in the design or operation of internal control over financial reporting which are reasonably likely to adversely affect the registrant's ability to record, process, summarize and report financial information; and
  - b) Any fraud, whether or not material, that involves management or other employees who have a significant role in the registrant's internal control over financial reporting.

Date: March 10, 2006

/s/ Charif Souki  
Charif Souki  
Chief Executive Officer

**CERTIFICATION BY CHIEF FINANCIAL OFFICER  
PURSUANT TO RULE 13a-14(a) AND 15d-14(a) UNDER THE EXCHANGE ACT**

I, Don A. Turkleson, certify that:

1. I have reviewed this annual report on Form 10-K of Cheniere Energy, Inc.;
2. Based on my knowledge, this report does not contain any untrue statement of a material fact or omit to state a material fact necessary to make the statements made, in light of the circumstances under which such statements were made, not misleading with respect to the period covered by this report;
3. Based on my knowledge, the financial statements, and other financial information included in this report, fairly present in all material respects the financial condition, results of operations and cash flows of the registrant as of, and for, the periods presented in this report;
4. The registrant's other certifying officers and I are responsible for establishing and maintaining disclosure controls and procedures (as defined in Exchange Act Rules 13a-15(e) and 15d-15(e)) and internal control over financial reporting (as defined in Exchange Act Rules 13a-15(f) and 15d-15(f)) for the registrant and have:
  - a) Designed such disclosure controls and procedures, or caused such disclosure controls and procedures to be designed under our supervision, to ensure that material information relating to the registrant, including its consolidated subsidiaries, is made known to us by others within those entities, particularly during the period in which this report is being prepared;
  - b) Designed such internal control over financial reporting, or caused such internal control over financial reporting to be designed under our supervision, to provide reasonable assurance regarding the reliability of financial reporting and the preparation of financial statements for external purposes in accordance with generally accepted accounting principles;
  - c) Evaluated the effectiveness of the registrant's disclosure controls and procedures and presented in this report our conclusions about the effectiveness of the disclosure controls and procedures, as of the end of the period covered by this report based on such evaluation;
  - d) Disclosed in this report any change in the registrant's internal control over financial reporting that occurred during the registrant's most recent fiscal quarter (the registrant's fourth fiscal quarter in the case of an annual report) that has materially affected, or is reasonably likely to materially affect, the registrant's internal control over financial reporting; and
5. The registrant's other certifying officers and I have disclosed, based on our most recent evaluation of internal control over financial reporting, to the registrant's auditors and the audit committee of the registrant's board of directors (or persons performing the equivalent functions):
  - a) All significant deficiencies and material weaknesses in the design or operation of internal control over financial reporting which are reasonably likely to adversely affect the registrant's ability to record, process, summarize and report financial information; and
  - b) Any fraud, whether or not material, that involves management or other employees who have a significant role in the registrant's internal control over financial reporting.

Date: March 10, 2006

/s/ Don A. Turkleson  
Don A. Turkleson  
Chief Financial Officer

**CERTIFICATION BY CHIEF EXECUTIVE OFFICER  
PURSUANT TO 18 U.S.C. SECTION 1350,  
AS ADOPTED PURSUANT TO  
SECTION 906 OF THE SARBANES-OXLEY ACT OF 2002**

In connection with the Annual Report of Cheniere Energy, Inc. (the "Company") on Form 10-K for the period ending December 31, 2005 as filed with the Securities and Exchange Commission on the date hereof (the "Report"), I, Charif Souki, Chief Executive Officer of the Company, certify, pursuant to 18 U.S.C. § 1350, as adopted pursuant to § 906 of the Sarbanes-Oxley Act of 2002, to my knowledge, that:

- (1) The Report fully complies with the requirements of section 13(a) or 15(d) of the Securities Exchange Act of 1934; and
- (2) The information contained in the Report fairly presents, in all material respects, the financial condition and result of operations of the Company.

/s/ Charif Souki  
Charif Souki  
Chief Executive Officer

March 10, 2006



**CERTIFICATION BY CHIEF EXECUTIVE OFFICER  
PURSUANT TO 18 U.S.C. SECTION 1350,  
AS ADOPTED PURSUANT TO  
SECTION 906 OF THE SARBANES-OXLEY ACT OF 2002**

In connection with the Annual Report of Cheniere Energy, Inc. (the "Company") on Form 10-K for the period ending December 31, 2005 as filed with the Securities and Exchange Commission on the date hereof (the "Report"), I, Don A. Turkleson, Chief Financial Officer of the Company, certify, pursuant to 18 U.S.C. § 1350, as adopted pursuant to § 906 of the Sarbanes-Oxley Act of 2002, to my knowledge, that:

- (1) The Report fully complies with the requirements of section 13(a) or 15(d) of the Securities Exchange Act of 1934; and
- (2) The information contained in the Report fairly presents, in all material respects, the financial condition and result of operations of the Company.

/s/ Don A. Turkleson  
Don A. Turkleson  
Chief Financial Officer

March 10, 2006